



FABRICACION DE CILINDROS HIDRAULICOS
MANUFACTURING OF HYDRAULIC CYLINDERS

CILINDRO SIMPLE EFECTO ESTANDAR

Single acting hydraulic cylinder

4

SERIE 100

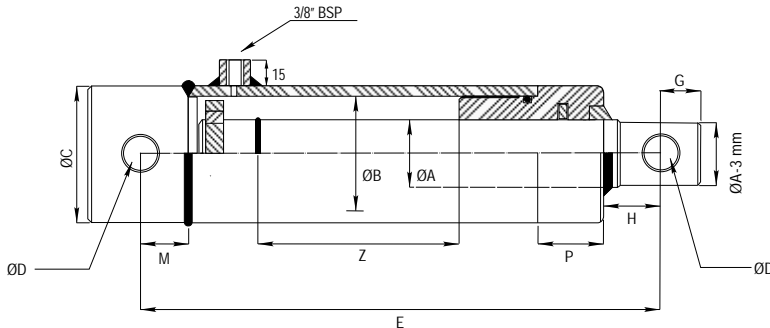

ØA
Ø25 → Ø40

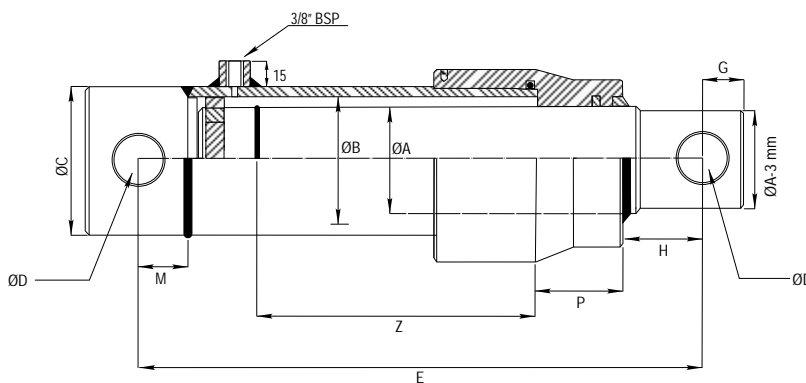

ØA
Ø45 → Ø90

Presión de trabajo: 180 bars.
Velocidad: 0.5 m/s.
Temperatura de trabajo: -25°C - +80°C
Aceite: Aceite mineral
Vástago: C45 f7 25 micras.
Tubo: St52.3 Din2393 Iso H9

Working pressure: 180 bars.
Speed: 0.5 m/s.
Working temperature: -25°C - +80°C.
Oil: Mineral oil.
Rod: C45 f7 25 microns.
Tube: St52.3 Din2393 Iso H9

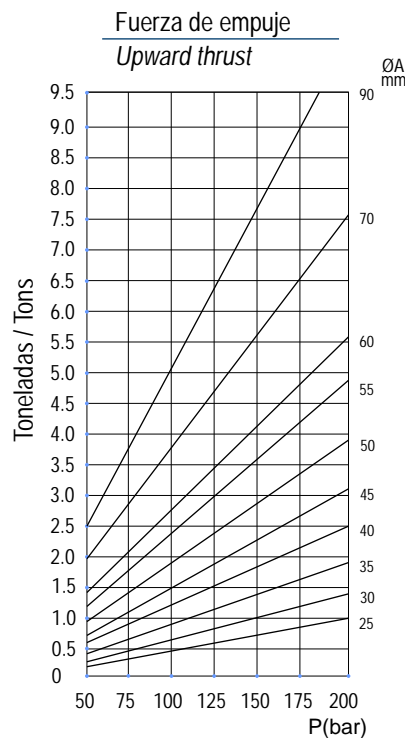
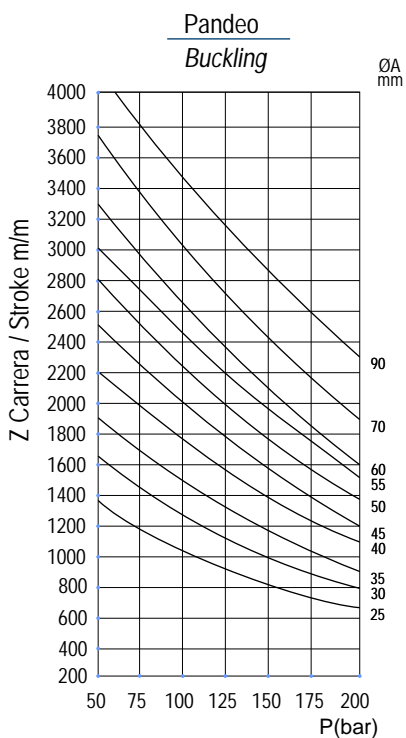

1 bar= 14.21 psi

Cálculo de la fuerza de empuje

$$\text{Empuje} = \pi \times r^2 \times \text{presión}(\text{bar})$$

Ejemplo = Cilindro 40-50/60

$$3.14 \times 2.5^2 \times 150(\text{bar})$$

$$\text{Total} = 2.943,75 \text{ Kgs.}$$

Cálculo del volumen de un cilindro

$$\text{Volumen} = \pi \times r^2 \times h(\text{altura})$$

Ejemplo = Cilindro 40-50/60-2000(mm.)

$$3.14 \times 2.5^2 \times 0,2$$

$$\text{Total} = 3,925 \text{ lts.}$$

CILINDRO SIMPLE EFECTO ESTANDAR

Single acting hydraulic cylinder



SERIE 100

Referencia Reference	ØA	Z Carrera Stroke	E	G	D	C	H	M	P	Vol. (litros) (liters)	Peso Weight Kgs.
100/010	25	100	190	14	14.25	40	20	17	20	0.08	1.50
100/020		200	290							0.16	2.30
100/030		300	390							0.24	3.00
101/020	30	200	300	15	16.25	50	22	22	22	0.25	3.60
101/030		300	400							0.38	4.70
101/040		400	500							0.50	6.00
101/050		500	600							0.69	7.60
101/070		700	800							0.88	9.40
102/020	35	200	330	17	20.50	55	24	25	24	0.32	4.70
102/030		300	430							0.48	6.10
102/040		400	530							0.64	7.50
102/050		500	630							0.87	9.60
102/070		700	830							1.11	11.70
103/020	40	200	330	17	20.50	60	32	25	32	0.39	6.00
103/030		300	430							0.59	7.60
103/040		400	530							0.79	9.30
103/050		500	630							1.08	11.70
103/070		700	830							1.37	14.20
104/020	45	200	330	23	25.50	60	35	29	35	0.39	7.00
104/030		300	430							0.59	8.90
104/040		400	530							0.79	10.90
104/050		500	630							1.08	13.70
104/070		700	830							1.37	16.70
105/020	50	200	360	23	25.50	65	35	29	44	0.48	8.90
105/030		300	460							0.71	11.20
105/040		400	560							0.95	13.50
105/050		500	660							1.31	16.80
105/070		700	860							1.66	20.40
106/030	55	300	460	25	30.50	70	40	29	52	0.85	13.60
106/050		500	660							1.56	19.30
106/070		700	860							1.98	24.20
107/020	60	200	360	25	30.50	75	40	29	67	0.66	12.60
107/030		300	460							1.00	15.70
107/040		400	560							1.33	18.70
107/050		500	660							1.83	23.30
107/070		700	860							2.32	28.40
108/030	70	300	480	25	30.50	90	40	29	67	1.51	25.10
108/040		400	580							2.02	29.60
108/050		500	680							2.52	34.50
108/070		700	880							3.53	43.40
109/030	90	300	480	25	30.50	115	40	29	67	2.37	36.50
109/050		500	680							3.94	41.50
109/070		700	880							5.52	48.50

* Unidades en milímetros.
Units in millimeters.

CILINDRO DOBLE EFECTO ESTANDAR

Double acting hydraulic cylinder



SERIE 200

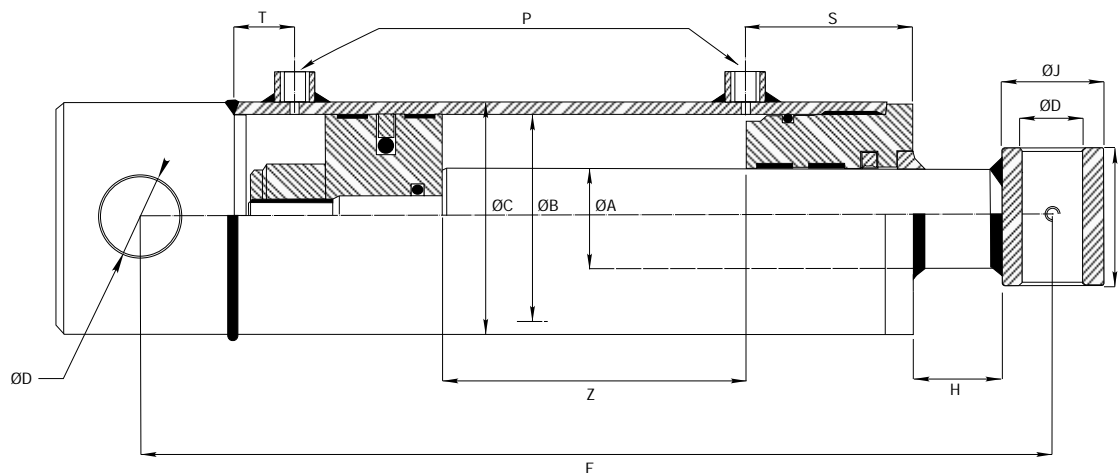

Presión de trabajo: 180 bars.
 Velocidad: 0.5 m/s.
 Temperatura de trabajo: -25°C - +80°C
 Aceite: Aceite mineral
 Vástago: C45 f7 25 micras.
 Tubo: St52.3 Din2393 Iso H9

Working pressure: 180 bars.
 Speed: 0.5 m/s.
 Working temperature: -25°C - +80°C.
 Oil: Mineral oil.
 Rod: C45 f7 25 microns.
 Tube: St52.3 Din2393 Iso H9

Cálculo del volumen de un cilindro

Volumen = $\pi \times r^2 \times h$ (altura)
 Ejemplo = Cilindro 40-70/80-400(mm.)
 $3.14 \times 3.5^2 \times 0.04$ (mts.)
 Total = 1,5386 lts.

Cálculo de la fuerza de empuje

Empuje = $\pi \times r^2 \times \text{presión}(\text{bar})$
 Ejemplo = Cilindro 40-70/80
 $3.14 \times 3.5^2 \times 150$ (bar)
 Total = 5.769,75 Kgs.

Cálculo de la fuerza de tracción

Empuje = $\pi \times r^2 \times \text{presión}(\text{bar})$
 Ejemplo = Cilindro 40-70/80
 Calcular área vástago: $3.14 \times 2.0^2 = 12.56$
 Calcular área tubo: $3.14 \times 3.5^2 = 38.465$
 Restar áreas: $38.465 - 12.56 = 25.905$
 Fuerza: 25.905×150 (bar) = 3.885,79 Kgs.

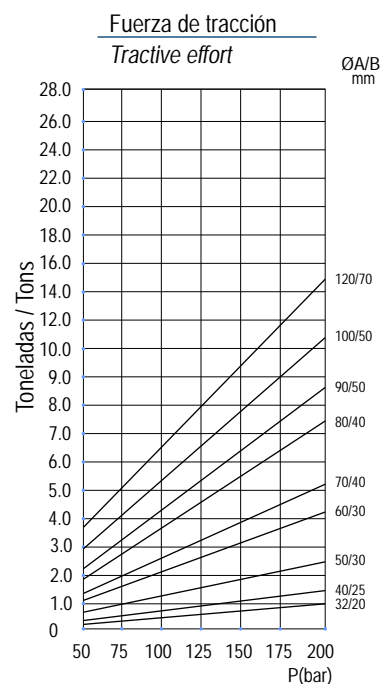
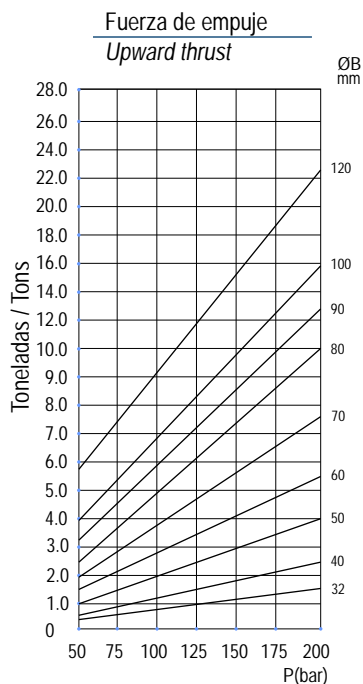
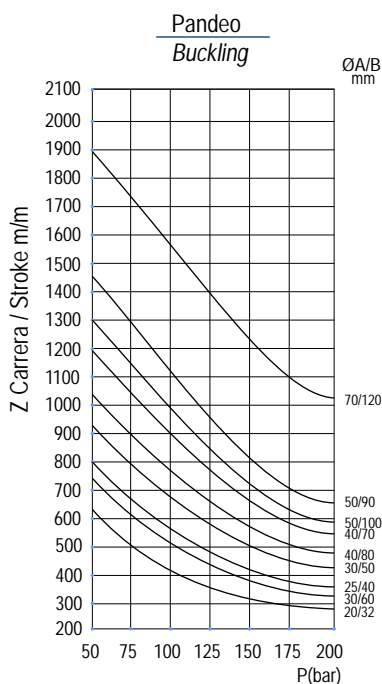

CILINDRO DOBLE EFECTO ESTANDAR

Double acting hydraulic cylinder



SERIE 200

Referencia Reference	ØA	Z Carrera Stroke	E	B	C	D	H	T	J	R	S	P	Vol. (litros) (liters)	Peso Weight Kgs.	
200/010	20	100	255	32	40	16.25	46	10	30	35	33	1/4"	0.10	2.00	
200/020		200	355										0.17	2.60	
200/030		300	455										0.25	3.20	
201/020	25	200	370	40	50	20.50	30	16	35	40	42	3/8"	0.25	3.80	
201/030		300	470										0.40	4.80	
201/040		400	570										0.55	5.80	
201/050		500	670										0.60	6.80	
201/060		600	770										0.75	7.80	
201/070		700	870										0.90	8.80	
202/020		30	200										400	50	60
202/030	300		500	0.59	7.06										
202/040	400		600	0.79	8.28										
202/050	500		700	0.98	9.50										
202/060	600		800	1.18	10.72										
202/070	700		900	1.37	11.94										
203/020	30		200	400	60	70	25.50	46	20	40	45	47	3/8"	0.57	7.08
203/030			300	500										0.85	8.46
203/040			400	600										1.13	9.84
203/050			500	700										1.41	11.22
203/060		600	800	1.70										12.60	
203/070	700	900	1.98	13.98											
204/020	40	200	410	70	80	30.50	34	26	50	55	51	3/8"	0.77	10.39	
204/030		300	510										1.15	12.22	
204/040		400	610										1.54	14.05	
204/050		500	710										1.92	15.88	
204/060		600	810										2.31	17.71	
204/070		700	910	2.69	19.54										
205/020		40	200	410	80	90	30.50	21	26	50	55	56	3/8"	1.01	12.10
205/030			300	510										1.51	14.10
205/040			400	610										2.01	16.10
205/050			500	710										2.51	18.10
205/060	600		810	3.02										20.10	
205/070	700	910	3.52	22.10											
206/020	50	200	425	90	100	30.50	28	26	60	70	60	3/8"	1.27	15.15	
206/030		300	525										1.91	18.15	
206/040		400	625										2.54	21.15	
206/050		500	725										3.17	24.15	
206/060		600	825										3.80	27.15	
206/070		700	925	4.43	30.15										
207/030		50	300	525	100	115	30.50	25	26	60	70	67	1/2"	2.36	27.60
207/040	400		625	3.14										30.80	
207/050	500		725	3.94										34.00	
207/060	600		825	4.74										37.20	
207/070	700		925	5.54										40.40	
208/040	70	400	710	120	140	40.50	39	30	80	80	67	1/2"	4.23	55.00	
208/050		500	810										5.65	62.50	
208/060		600	910										7.07	70.00	
208/070		700	1010										8.49	77.50	

* Unidades en milímetros.
Units in millimeters.

CILINDRO DOBLE EFECTO (Sin amarres)

Double acting hydraulic cylinder (No ends)



SERIE 300

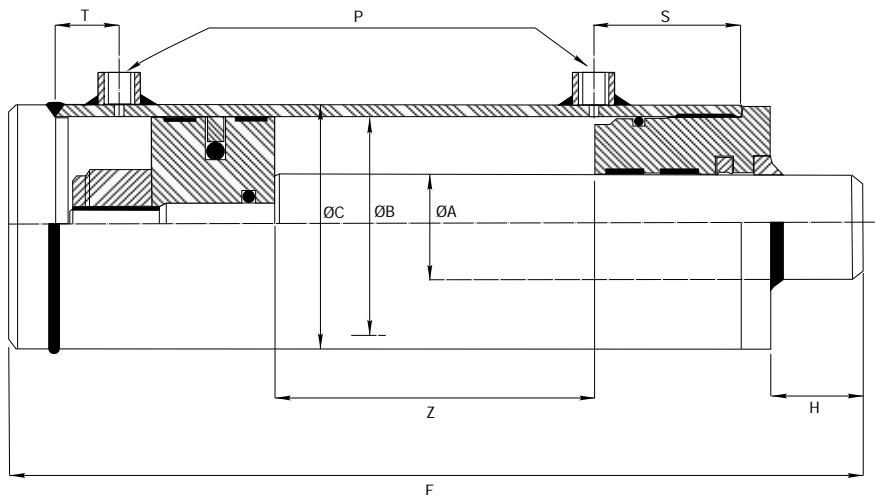

Presión de trabajo: 180 bars.
 Velocidad: 0.5 m/s.
 Temperatura de trabajo: -25°C - +80°C
 Aceite: Aceite mineral
 Vástago: C45 f7 25 micras.
 Tubo: St52.3 Din2393 Iso H9

Working pressure: 180 bars.
 Speed: 0.5 m/s.
 Working temperature: -25°C - +80°C.
 Oil: Mineral oil.
 Rod: C45 f7 25 microns.
 Tube: St52.3 Din2393 Iso H9

Cálculo del volumen de un cilindro

Volumen = $\pi \times r^2 \times h$ (altura)
 Ejemplo = Cilindro 40-70/80-400(mm.)
 $3.14 \times 3.5^2 \times 0.04$ (mts.)
 Total = 1,5386 lts.

Cálculo de la fuerza de empuje

Empuje = $\pi \times r^2 \times \text{presión}(\text{bar})$
 Ejemplo = Cilindro 40-70/80
 $3.14 \times 3.5^2 \times 150$ (bar)
 Total = 5.769,75 Kgs.

Cálculo de la fuerza de tracción

Empuje = $\pi \times r^2 \times \text{presión}(\text{bar})$
 Ejemplo = Cilindro 40-70/80
 Calcular área vástago: $3.14 \times 2.0^2 = 12,56$
 Calcular área tubo: $3.14 \times 3.5^2 = 38,465$
 Restar áreas: $38,465 - 12,56 = 25,905$
 Fuerza: $25,905 \times 150$ (bar) = 3.885,79 Kgs.

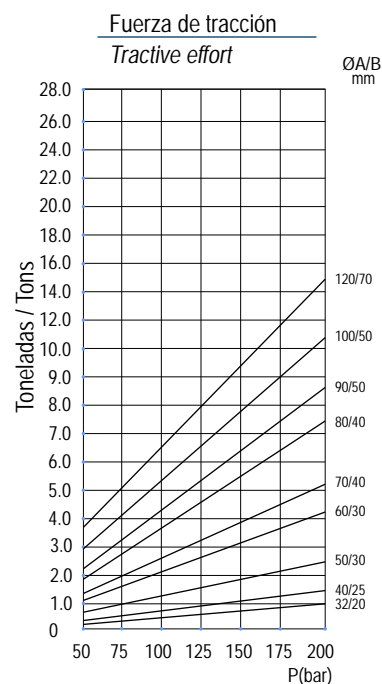
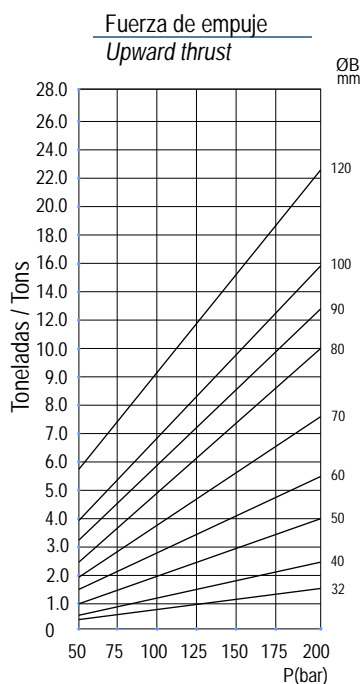
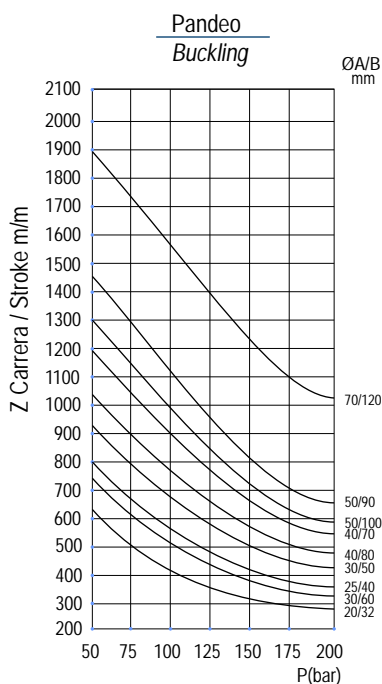

CILINDRO DOBLE EFECTO (Sin amarres)

Double acting hydraulic cylinder (No ends)



SERIE 300

Referencia Reference	ØA	Z Carrera Stroke	E	B	C	H	T	S	P	Vol. (litros) (liters)	Peso Weight Kgs.	
300/010	20	100	233	32	40	46	10	33	1/4"	0.10	1.90	
300/020		200	333							0.16	2.50	
300/030		300	433							0.24	3.10	
301/020	25	200	345	40	50	30	16	42	3/8"	0.25	3.50	
301/030		300	445							0.38	4.50	
301/040		400	545							0.50	5.50	
301/050		500	645							0.69	6.50	
301/060		600	745							0.76	7.50	
301/070		700	845							0.88	8.50	
302/020	30	200	370	50	60	47	20	43	3/8"	0.39	4.90	
302/030		300	470							0.59	6.20	
302/040		400	570							0.79	7.50	
302/050		500	670							0.98	8.80	
302/060		600	770							1.18	10.10	
302/070		700	870	1.37	11.40							
303/020		30	200	371	60	70		46	47	3/8"	0.57	6.20
303/030			300	471							0.85	7.50
303/040			400	571							1.13	8.90
303/050			500	671							1.41	10.30
303/060	600		771	1.70			11.60					
303/070	700		871	1.98			13.00					
304/020	40	200	371	70	80	34	26	51	3/8"	0.77	8.70	
304/030		300	471							1.15	10.60	
304/040		400	571							1.54	12.60	
304/050		500	671							1.92	14.50	
304/060		600	771							2.31	16.40	
304/070		700	871	2.69	18.30							
305/020		40	200	371	80	90		21	56	3/8"	1.01	11.60
305/030			300	471							1.51	13.80
305/040			400	571							2.01	16.10
305/050			500	671							2.51	18.40
305/060	600		771	3.02			20.60					
305/070	700		871	3.52			22.90					
306/020	50	200	382	90	100	28	60	3/8"	1.27	14.10		
306/030		300	482						1.91	17.05		
306/040		400	582						2.54	20.10		
306/050		500	682						3.17	23.15		
306/060		600	782						3.80	26.20		
306/070		700	882	4.43	29.35							
307/030		50	300	487	100	115		25	67	1/2"	2.36	23.90
307/040			400	587							3.14	27.40
307/050			500	687							3.94	30.90
307/060			600	787							4.74	34.50
307/070	700		887	5.54			38.00					
308/040	70		400	655			120				140	39
308/050		500	755	5.65	57.25							
308/060		600	855	7.07	64.50							
308/070		700	955	8.49	71.80							

* Unidades en milímetros.
Units in millimeters.

CILINDRO DOBLE EFECTO SERIE 400

Double acting hydraulic cylinder 400 series

10

SERIE 400

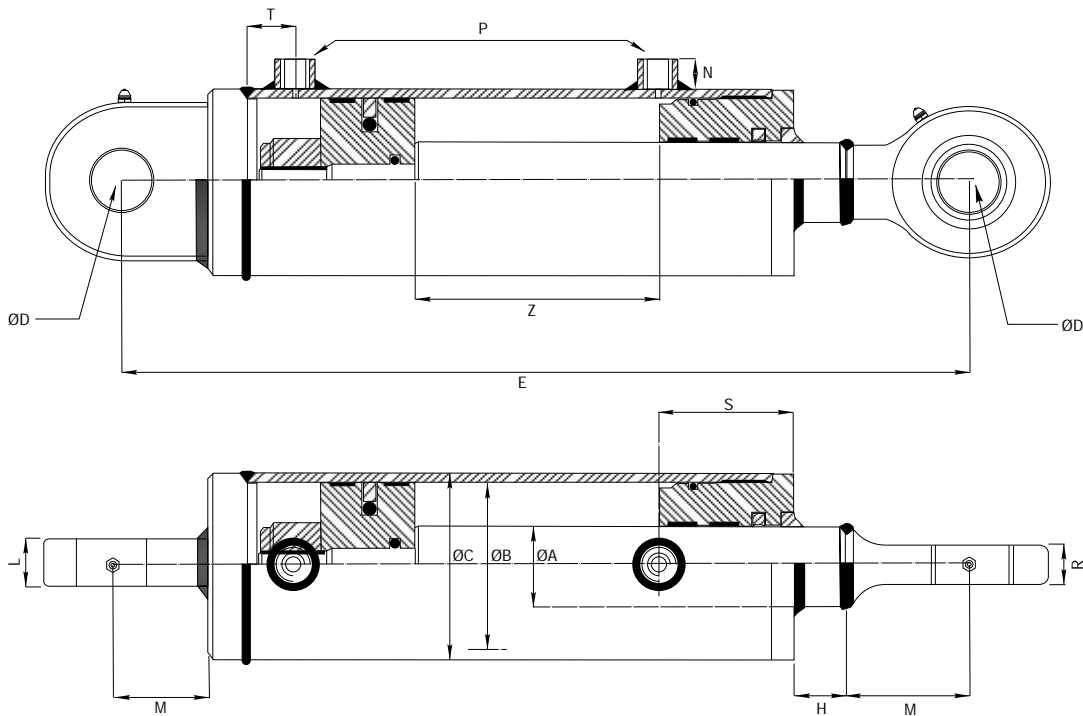

Presión de trabajo: 180 bars.
 Velocidad: 0.5 m/s.
 Temperatura de trabajo: -25°C - +80°C
 Aceite: Aceite mineral
 Vástago: C45 f7 25 micras.
 Tubo: St52.3 Din2393 Iso H9

Working pressure: 180 bars.
 Speed: 0.5 m/s.
 Working temperature: -25°C - +80°C.
 Oil: Mineral oil.
 Rod: C45 f7 25 microns.
 Tube: St52.3 Din2393 Iso H9

Opción: Kit válvula antirretorno doble pilotada (VADP008EX).
 Rótulas Serie TAC y TPN soldadas.

Option: Dual pilot operated check valve set. (VADP008EX).
 TAC and TPN series welded ball joints.

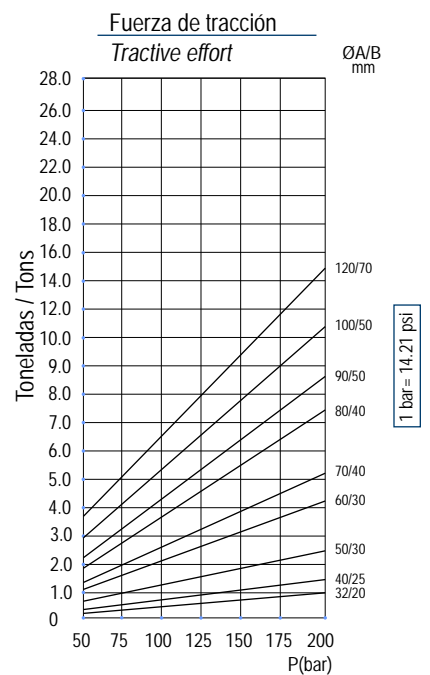
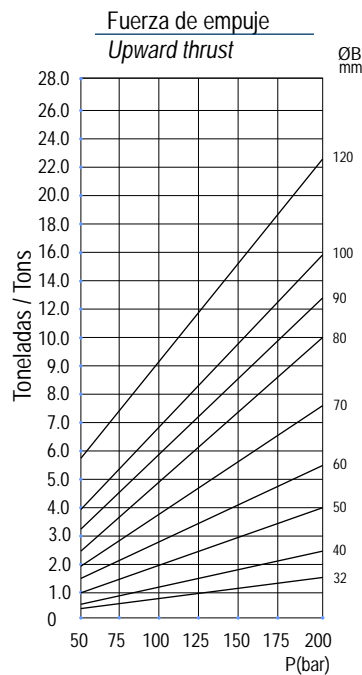
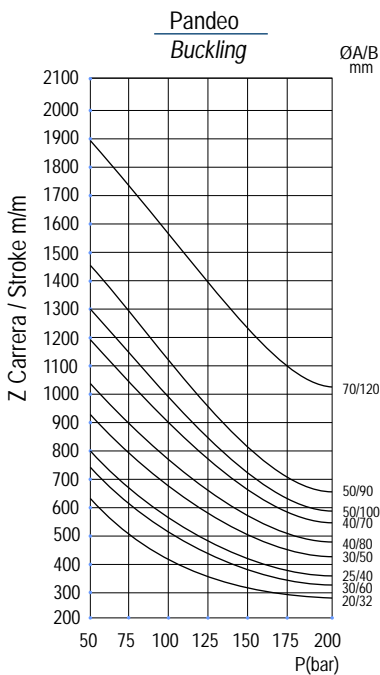

CILINDRO DOBLE EFECTO SERIE 400

Double acting hydraulic cylinder 400 series



SERIE 400

Referencia Reference	ØA	Z Carrera Stroke	E	B	C	D	H	T	N	L	S	M	R	P	Vd. (litros) (liters)	Peso Weight Kgs.											
400/010	20	100	280	32	40	20.25	14	10	16	19	33	38	16	1/4"	0.10	2.50											
400/020		200	380												0.16	3.10											
400/030		300	480												0.24	3.70											
401/020	25	200	410	40	50	20.25	19	16	16	19	42	38	16	3/8"	0.25	4.10											
401/030		300	510												0.38	5.10											
401/040		400	610												0.50	6.10											
401/050		500	710												0.69	7.10											
401/060		600	810												0.76	8.10											
401/070		700	910												0.88	9.10											
402/020	30	200	430	50	60	25.25	17	20	16	23	43	45	20	3/8"	0.39	5.90											
402/030		300	530												0.59	7.20											
402/040		400	630												0.79	8.50											
402/050		500	730												0.98	9.80											
402/060		600	830												1.18	11.10											
402/070		700	930	1.37	12.40																						
403/020		200	430	60	70	25.25	15	20	16	23	47	45	20	3/8"	0.57	7.20											
403/030		300	530												0.85	8.50											
403/040		400	630												1.13	9.80											
403/050		500	730												1.41	11.10											
403/060	600	830	1.70												12.40												
403/070	700	930	1.98	13.70																							
404/020	40	200	465	70	80	30.25	26	26	16	28	51	51	22	3/8"	0.77	10.25											
404/030		300	565												1.15	12.15											
404/040		400	665												1.54	14.05											
404/050		500	765												1.92	15.95											
404/060		600	865												2.31	17.85											
404/070		700	965												2.69	19.75											
405/020		200	465												80	90	30.25	13	26	16	28	56	51	22	3/8"	1.01	13.15
405/030		300	565	1.51	15.35																						
405/040		400	665	2.01	17.55																						
405/050		500	765	2.51	19.75																						
405/060		600	865	3.02	21.95																						
405/070		700	965	3.52	24.15																						
406/020		50	200	510	90	100	40.25	18	20	16	35	60	69	28												3/8"	1.27
406/030			300	610											1.91	20.75											
406/040	400		710	2.54											23.70												
406/050	500		810	3.17											26.65												
406/060	600		910	3.80											29.60												
406/070	700		1010	4.43	32.55																						
407/030	300		615	100	115	40.25	15	20	16	35	67	69	28	1/2"	2.36	27.60											
407/040	400		715												3.14	31.10											
407/050	500		815												3.94	34.60											
407/060	600		915												4.74	38.10											
407/070	700	1015	5.54												41.60												
408/040	70	400	770												120	140	50.25	17	30	20	40	67	88	35	1/2"	4.23	57.00
408/050		500	870																							5.65	64.15
408/060		600	970	7.07	71.30																						
408/070		700	1070	8.49	78.45																						

* Unidades en milímetros.
Units in millimeters.

CILINDRO DOBLE EFECTO (Brida delantera)

Double acting hydraulic cylinder (Front flange)

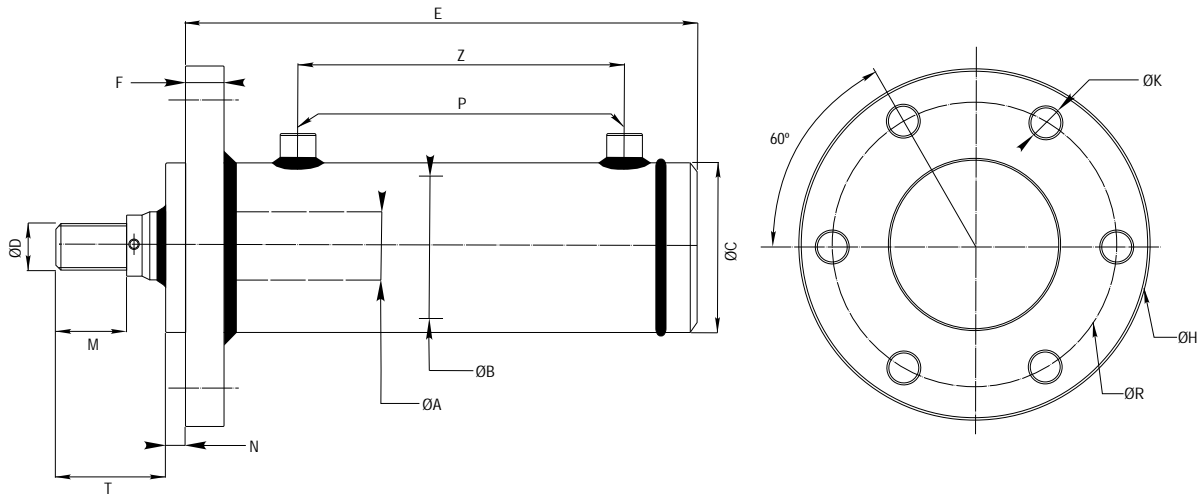

Opción: Para trabajos intensivos, es posible sustituir la estanqueidad, por juntas de baja fricción, y alta presión de trabajo.

Option: For intensive work, leakage can be replaced by low friction joints and high pressure.

SERIE 500

Referencia Reference	ØA	Z Carrera Stroke	E	B	C	D	H	T	M	N	K	F	R	P	
500/Z	20	50-2000	79+Z	32	40	M14X1.5	80	35	18	8	7	10	67	1/4"	
501/Z	20		108+Z	40	50	M16X1.5	100	40	22	7	9	12	82	3/8"	
502/Z	25		115+Z	50	60	M20X1.5	125	48	28	8	11	12	103	3/8"	
503/Z	25			117+Z	60	70	M27X2.0	145	58	36	8	13	12	120	3/8"
504/Z	30		127+Z		70	80	M27X2.0	160	58	36	10	15	15	130	3/8"
505/Z	35			140+Z	80	90	M33X2.0	170	68	45	10	15	15	142	3/8"
506/Z	30		144+Z		90	100	M33X2.0	202	68	45	10	17	15	170	3/8"
507/Z	35			147+Z	100	115	M42X2.0	202	85	56	15	17	15	170	1/2"
508/Z	40		201+Z		120	140	M48X2.0	250	92	63	15	21	30	210	1/2"
509/Z	35			201+Z	130	150	M64X2.0	280	120	85	15	21	30	230	3/4"
510/Z	40														
511/Z	45														
512/Z	50														
513/Z	35														
514/Z	40														
515/Z	45														
516/Z	50														
517/Z	40														
518/Z	45														
519/Z	50														
520/Z	50														
521/Z	60														
522/Z	70														
523/Z	60														
524/Z	70														
525/Z	80														
526/Z	70														
527/Z	80														
528/Z	90														

* Unidades en milímetros.
Units in millimeters.

CILINDRO DE VOLTEO DE ARADO

Turn-over plough cylinder

13

SERIE 590

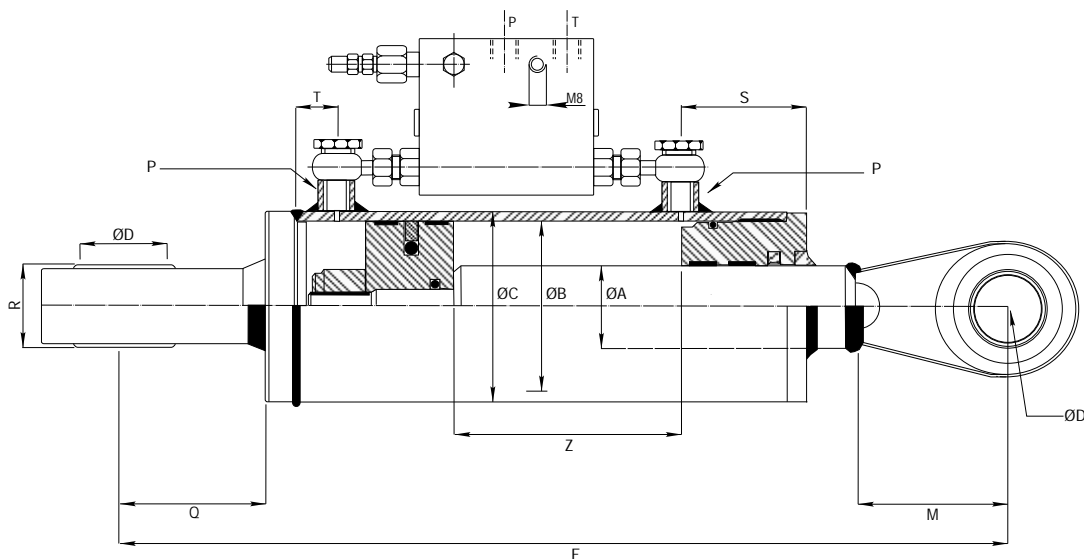

Esquema hidráulico válvula
Hydraulic valve diagram

Funcionamiento: Pueden ser montados en circuitos tanto de simple como de doble efecto. Están provistas de rótulas TAC y TPN para un montaje más sencillo.

Operation: Can be mounted on a circuit of single and double acting. It is equipped with TAC and TPN ball joints for easier mounting.

Referencia válvula volteo arado : VSEB03802. (Montaje en tubo Din2353).

Reference of the turn-over plough valve: VSEB03802. (Mounting in pipe Din2353).

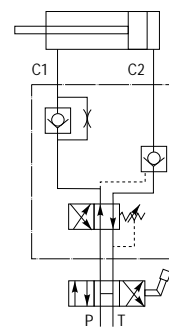

Referencia Reference	ØA	Z Carrera Stroke	E	B	C	D	Q	M	S	R	P	T	Vol. (litros) (liters)	Peso Weight Kgs.
591/016	30	160	400	50	60	30.2	51	51	43	28	3/8"	20	0.30	8.50
592/016	40			70	80		51	51	51	28	3/8"	26	0.60	11.80
593/016	40			80	90		56	28	0.85	13.20				

* Unidades en milímetros.
Units in millimeters.

CILINDRO TERCER PUNTO ESTÁNDAR

Standard hydraulic top link

14

SERIE 600

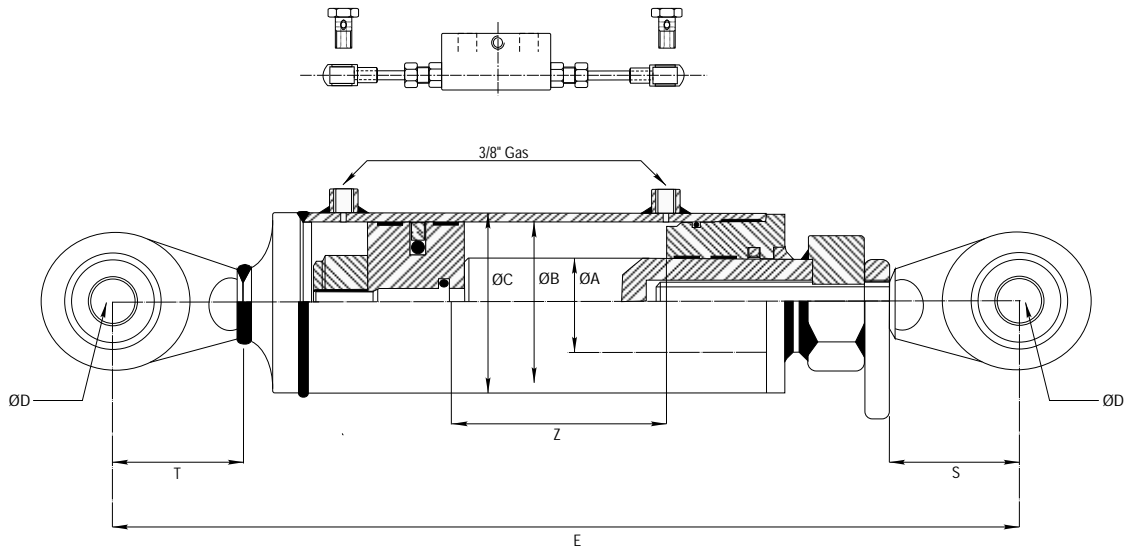

Opción 1ª: Kit válvula antirretorno doble pilotada (VADP008EX).
Longitud entre centros ajustable .

Opción 2ª: Posibilidad de cambiar la rótula agrícola estándar del vástago por enganche rápido. (Cat.2).

Option 1st: Dual pilot operated check valve set. (VADP008EX).
Adjustable length between centers.

Option 2nd: Ability to change the standard ball joint for rapid hook in the rod. (Cat.2).

*Consultar serie 600/...E
*Consult 600/...E series

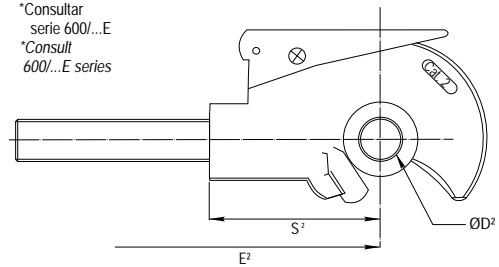

Presión de trabajo: 180 bars.
Velocidad: 0.5 m/s.
Temperatura de trabajo: -25°C - +80°C
Aceite: Aceite mineral
Vástago: C45 f7 25 micras.
Tubo: St52.3 Din2393 Iso H9

Working pressure: 180 bars.
Speed: 0.5 m/s.
Working temperature: -25°C - +80°C.
Oil: Mineral oil.
Rod: C45 f7 25 microns.
Tube: St52.3 Din2393 Iso H9

Referencia Reference	ØA	Z Carrera Stroke	E	E²	B	C	D	D²	S	S²	T	Vol. (litros) (liters)	Peso Weight Kgs.
600/020	40	200	510		60	70	25.40		55		65	0.60	11.50
600/025		250	560									0.75	12.50
600/030		300	610									0.90	13.50
601/020	45	200	530		70	80					70	0.80	14.00
601/025		250	580									1.05	15.00
601/030		300	630									1.25	16.00
600/020E	40	200		560	60	70		19.30		105	65	0.60	13.50
600/025E		250		610				22.40				0.75	14.50
600/030E		300		660				25.40				0.90	15.50
601/020E	45	200		580	70	80		30.40			70	0.80	16.00
601/025E		250		630				28.40				1.05	17.00
601/030E		300		680				32.40				1.25	18.00

* Unidades en milímetros.
Units in millimeters.

CILINDRO TERCER PUNTO (FIJO)

Hydraulik top link (Fixed)

15

SERIE 610

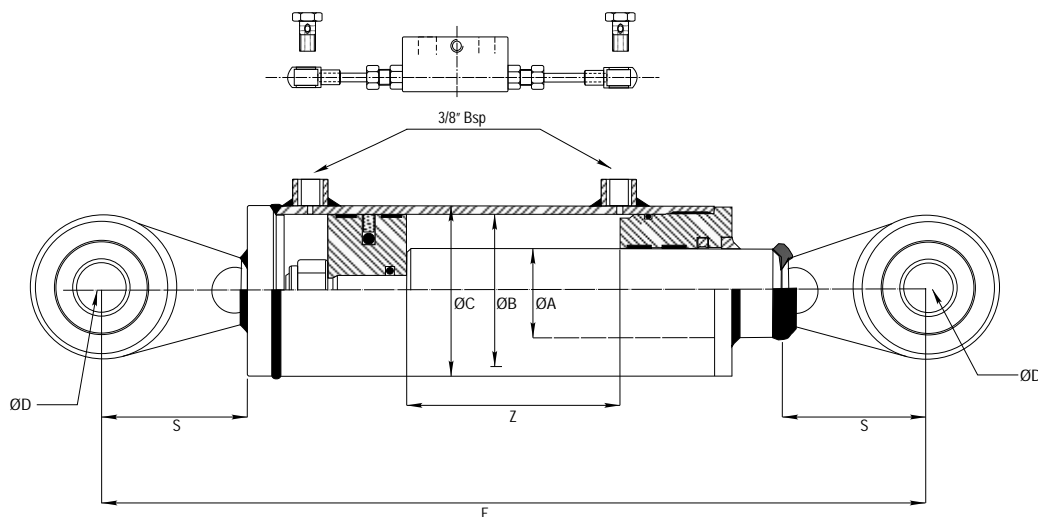

Presión de trabajo: 180 bars.
 Velocidad: 0.5 m/s.
 Temperatura de trabajo: -25°C - +80°C
 Aceite: Aceite mineral
 Vástago: C45 f7 25 micras.
 Tubo: St52.3 Din2393 Iso H9

Working pressure: 180 bars.
 Speed: 0.5 m/s.
 Working temperature: -25°C - +80°C.
 Oil: Mineral oil.
 Rod: C45 f7 25 microns.
 Tube: St52.3 Din2393 Iso H9

Opción : Kit válvula antirretorno doble pilotada (VADP008EX).
 Rótulas soldadas.

Option : Dual pilot operated check valve set. (VADP008EX).
 Ball joints welded.

Referencia Reference	ØA	Z Carrera Stroke	E	B	C	ØD	S	Vol. (litros) (liters)	Peso Weight Kgs.
610/016	30	160	416	50	60	19.30	60	0.32	5.60
610/021		210	466			19.30		0.42	6.20
610/028		280	536			19.30		0.56	7.10
610/040		400	656			19.30		0.80	8.50
610/016A		160	426			25.40	65	0.32	6.30
610/021A		210	476			25.40		0.42	6.90
610/028A		280	546			25.40		0.56	7.90
610/040A		400	666			25.40		0.80	9.20
611/016	35	160	440	60	70	25.40	65	0.48	7.80
611/021		210	490			25.40		0.63	8.60
611/028		280	560			25.40		0.84	9.60
611/040		400	680			25.40		1.20	15.60
612/016	40	160	461	80	90	25.40	70	0.90	12.50
612/021		210	511			25.40		1.20	13.70
612/028		280	581			25.40		1.60	15.20
612/040		400	701			25.40		2.20	18.00

* Unidades en milímetros.
 Units in millimeters.

CILINDRO TERCER PUNTO (Enganche rápido)

Hydraulic top link (Rapid hook)

16

SERIE 620

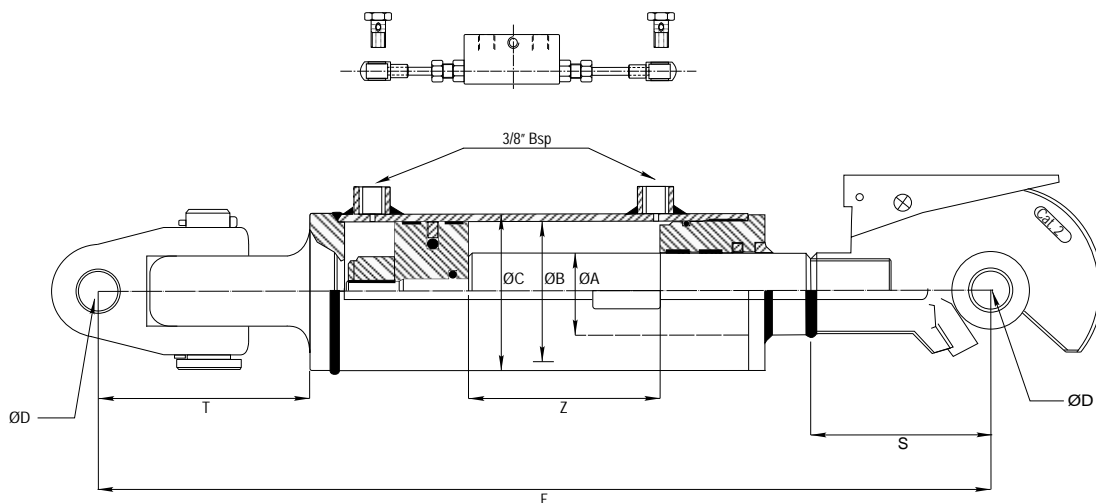

Presión de trabajo: 180 bars.
Velocidad: 0.5 m/s.
Temperatura de trabajo: -25°C - +80°C
Aceite: Aceite mineral
Vástago: C45 f7 25 micras.
Tubo: St52.3 Din2393 Iso H9

Working pressure: 180 bars.
Speed: 0.5 m/s.
Working temperature: -25°C - +80°C.
Oil: Mineral oil.
Rod: C45 f7 25 microns.
Tube: St52.3 Din2393 Iso H9

Opción : Kit válvula antirretorno doble pilotada (VADP008EX).
Rótulas soldadas.

Option : Dual pilot operated check valve set. (VADP008EX).
Ball joints welded.

Referencia Reference	ØA	Z Carrera Stroke	E	B	C	ØD	S	Categoría Range	T	Vol. (Litros) (Liters)	Peso Weight Kgs.	
620/020	35	200	550	60	70	19.40	105	Cat.2	95	0.55	12.50	
620/025		250	600							0.70	13.50	
621/020		200	550	70	80					20.40	0.95	14.00
621/025		250	600							22.40	1.15	15.50
622/020	40	200	600	80	95	25.40	132	Cat.3	95	1.10	18.00	
622/025		250	650							28.40	1.35	20.00
623/020		200	600	90	105					30.40	1.30	19.50
623/025		250	650							32.40	1.65	22.00
624/020	45	200	600	100	115	32.40				1.55	22.50	
624/025		250	650							1.90	25.50	

* Unidades en milímetros.
Units in millimeters.

CILINDRO TERCER PUNTO (Enganche rápido)

Hydraulic top link (Rapid hook)

17

SERIE 630

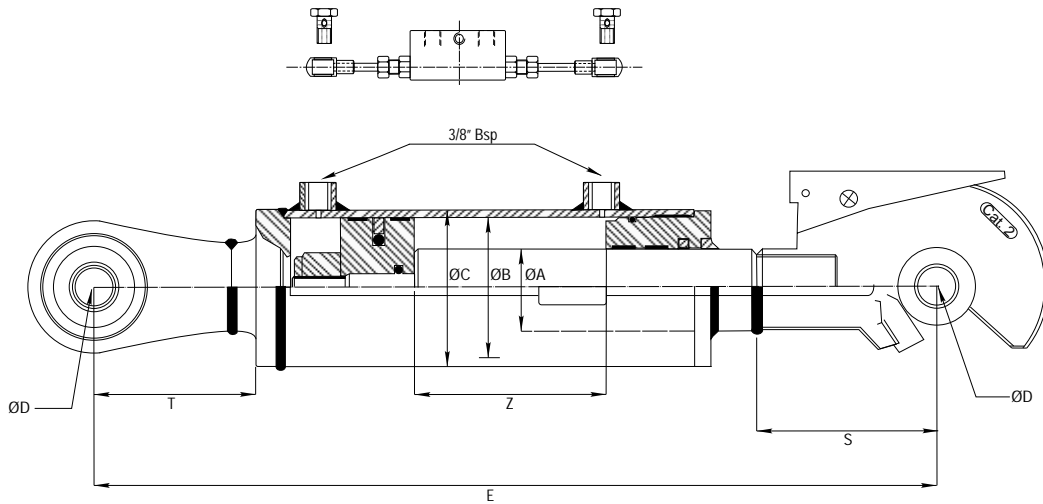

Presión de trabajo: 180 bars.
 Velocidad: 0.5 m/s.
 Temperatura de trabajo: -25°C - +80°C
 Aceite: Aceite mineral
 Vástago: C45 f7 25 micras.
 Tubo: St52.3 Din2393 Iso H9

Working pressure: 180 bars.
 Speed: 0.5 m/s.
 Working temperature: -25°C - +80°C.
 Oil: Mineral oil.
 Rod: C45 f7 25 microns.
 Tube: St52.3 Din2393 Iso H9

Opción : Kit válvula antirretorno doble pilotada (VADP008EX).
 Rótulas y enganche rápido soldados.

Option : Dual pilot operated check valve set. (VADP008EX).
 Ball joints and rapid hook welded.

Referencia Reference	ØA	Z Carrera Stroke	E	B	C	D	S	Categoría Range	T	Vol. (Litros) (Liters)	Peso Weight Kgs.
630/020	35	200	550	60	70	19.40	105	Cat.2	95	1.00	10.00
630/025		250	600							1.00	10.00
631/020		200	550	70	80	20.40				1.00	10.00
631/025		250	600							1.00	10.00
632/020	40	200	600	80	95	25.40	132	Cat.3	95	1.00	10.00
632/025		250	650							28.40	1.00
633/020		200	600	90	105	30.40				1.00	10.00
633/025		250	650							1.00	10.00
634/020	45	200	600	100	115	32.40	132	Cat.3	95	1.00	10.01
634/025		250	650							1.00	10.01

* Unidades en milímetros.
 * Units in millimeters.

CILINDRO TERCER PUNTO (Rótula ajustable)

Hydraulic top link (Adjustable ball joint)

18

SERIE 640

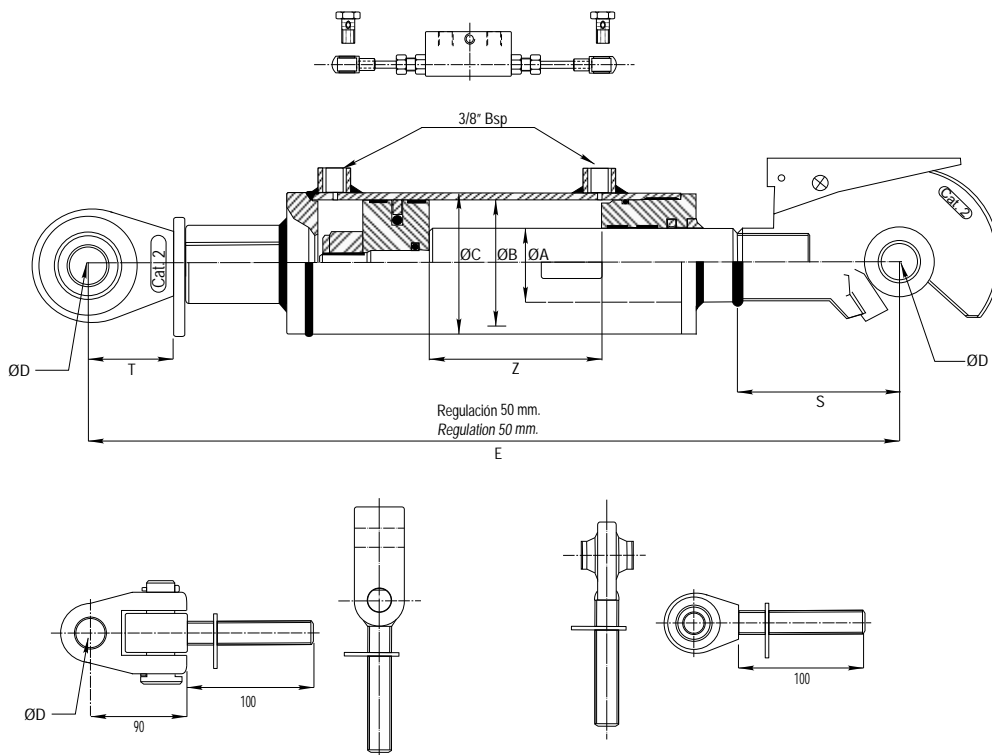

Opción 1ª : Cruceta articulada.
Option 1st : Articulated yoke.

Opción 2ª : Rótula articulada.
Option 2nd : Ball joint.

Presión de trabajo: 180 bars.
Velocidad: 0.5 m/s.
Temperatura de trabajo: -25°C - +80°C
Aceite: Aceite mineral
Vástago: C45 f7 25 micras.
Tubo: St52.3 Din2393 Iso H9

Working pressure: 180 bars.
Speed: 0.5 m/s.
Working temperature: -25°C - +80°C.
Oil: Mineral oil.
Rod: C45 f7 25 microns.
Tube: St52.3 Din2393 Iso H9

Opción : Kit válvula antirretorno doble pilotada (VADP008EX).
Eganche rápido soldado y rótula ajustable trasera / cruceta.

Option : Dual pilot operated check valve set. (VADP008EX).
Rapid hook welded and adjustable ball joint / articulated yoke.

Referencia Reference	ØA	Z Carrera Stroke	E	B	C	D	S	Categoría Range	T	Vol. (Litros) (Liters)	Peso Weight Kgs.
640/021	30	210	610	50	60	19.40	105	Cat.2	100	1.00	10.00
641/021	35		610	60	70	22.40	105	Cat.2		1.00	10.00
642/021	40		665	80	95	25.40	132	Cat.3		1.00	10.00
640/021C	30		645	50	60	30.40	105	Cat.2		1.00	10.00
641/021C	35		645	60	70	28.40	105	Cat.2		1.00	10.00
642/021C	40		700	80	95	32.40	132	Cat.3		1.00	10.00

* Unidades en milímetros.
Units in millimeters.

BRAZO LATERAL HIDRAULICO

Hydraulic levelling arm

19

SERIE 650

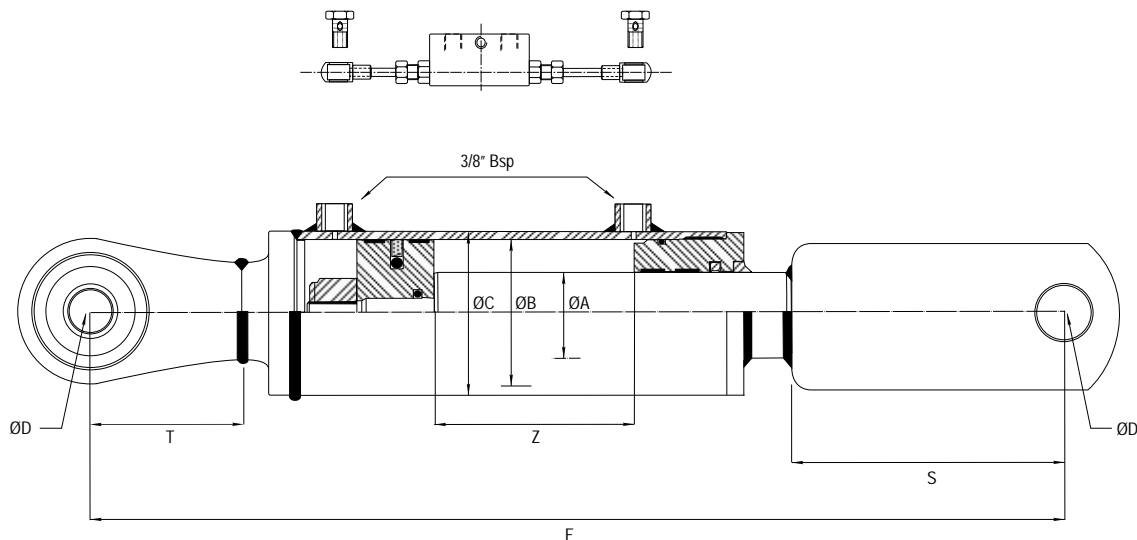

Presión de trabajo: 180 bars.

Velocidad: 0.5 m/s.

Temperatura de trabajo: -25°C - +80°C

Aceite: Aceite mineral

Vástago: C45 f7 25 micras.

Tubo: St52.3 Din2393 Iso H9

Working pressure: 180 bars.

Speed: 0.5 m/s.

Working temperature: -25°C - +80°C.

Oil: Mineral oil.

Rod: C45 f7 25 microns.

Tube: St52.3 Din2393 Iso H9

Opción : Kit válvula antirretorno doble pilotada (VADP008EX).
Option : Dual pilot operated check valve set. (VADP008EX).

Aplicación : John deere 36.50 - 40.50 - 40.55 - 42.50.
Application : John deere 36.50 - 40.50 - 40.55 - 42.50.

Referencia Reference	ØA	Z Carrera Stroke	E	B	C	D	S	T	Vol. (Litros) (Liters)	Peso Weight Kgs.
650/018	30	180	560	60	70	16.40	95	65	1.00	10.00
651/019	35	190	660	70	80	25.40	95	70	1.00	10.00
652/026	45	260	720	90	105	25.40	120	70	1.00	10.00

* Unidades en milímetros.
Units in millimeters.

CILINDRO DE FRENO (Simple efecto) Brake cylinder (Single acting)

CILINDRO DE FRENO ESTANDAR Standard brake cylinder

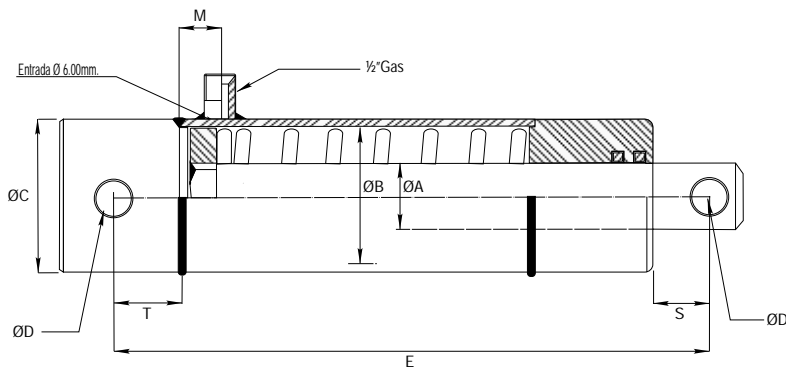

Referencia Reference	ØA	Z Carrera Stroke	E	B	C	D	S	T	M	Vol. (Litros) (Liters)	Peso Weight Kgs.
700/010	25	100	240	35	45	12.25	17	15	25	0.12	2.50

* Unidades en milímetros.
Units in millimeters.

CILINDRO DE FRENO (Tipo boggie) Brake cylinder (Boggie type)

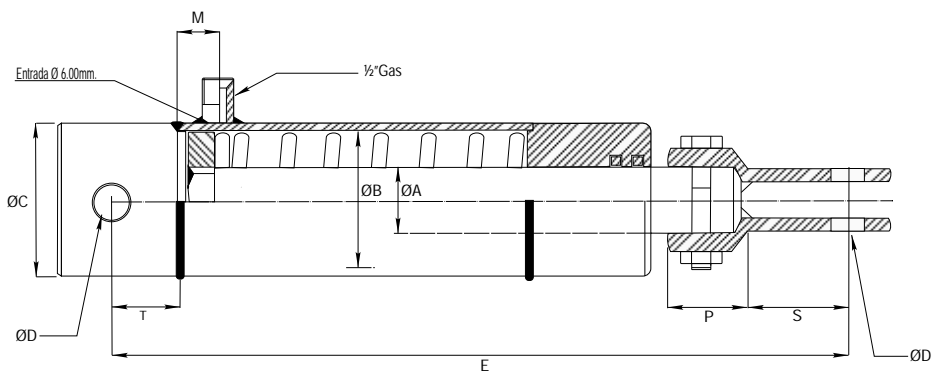

Referencia Reference	ØA	Z Carrera Stroke	E	B	C	D	S	T	P	M	Vol. (Litros) (Liters)	Peso Weight Kgs.
710/010	25	100	300	35	45	12.25	35	15	15	25	0.12	2.30

* Unidades en milímetros.
Units in millimeters.

PIE HIDRÁULICO (simple efecto) Hydraulic crutch (single acting)

SERIE 800

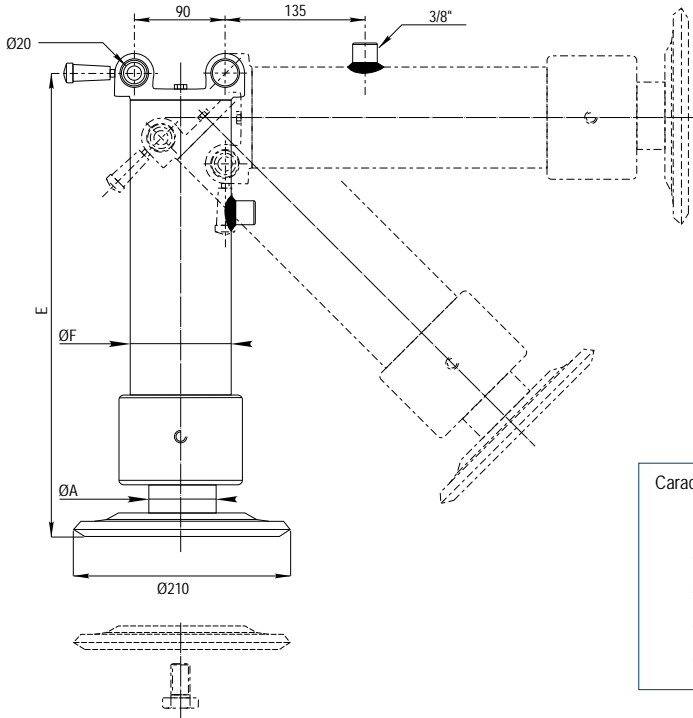

Características / Features:

- * Cilindro escamoteable / Retractable cylinder.
- * Retroceso por muelle / Spring return.
- * Presión de trabajo: 180 bars / Working pressure: 180 bars.
- * Fácil desmontaje / Easy disassembly.
- * Gran robustez / Robust design.

* Capacidad de elevación: (180bars).
* Lifting capacity: (180bars).

Serie 801 = 7 tons.

Serie 802 = 12 tons.

Referencia Reference	ØA	Z Carrera Stroke	E	F	Vol. (Litros) (Liters)	Peso Weight Kgs.
801/020	65	200	520	80	0.30	9.50
802/025	80	250	570	100	0.65	11.70

* Unidades en milímetros.
Units in millimeters.

Soporte basculante Swivel bracket

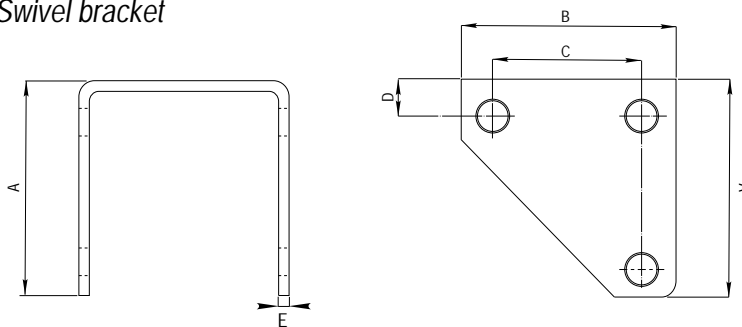

*Chapa tratada mediante zinc trivalente o similar.

*Acero en S152.3.

*Plate treated whit trivalent zinc or similar.

*Steel S152.3.

Referencia Reference	A	B	C	D	E	Peso Weight Kgs.
SPH142	142	140	90	40	7	2.65

* Unidades en milímetros.
Units in millimeters.

Casquillo estándar

Standard bush

CRA

* Unidades en milímetros.
Units in millimeters.

Referencia Reference	ØD	ØB	T	L	ØR	Peso Weight Kgs.
CRA0216	16	30	17.50	35	5.00	0.15
CRA0220	20	35	20.00	40	7.00	0.20
CRA0225	25	40	22.50	45	7.00	0.30
CRA0230	30	50	27.50	55	7.00	0.55
CRA0240	30	60	30.00	70	7.00	1.15
CRA0250	40	80	40.00	80	8.50	2.35
CRA0260	40	90	50.00	100	8.50	3.25

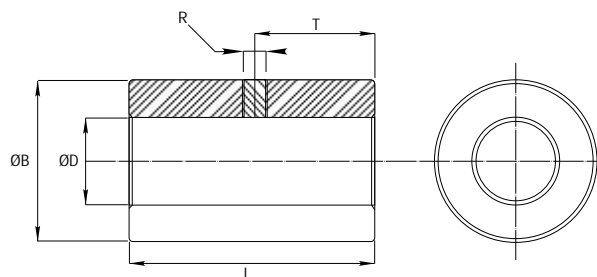

Material en S152.3 / Material in S152.3.
Otras medidas bajo pedido / Others measures on request.

Fondo taladrado estándar

End-plug whit hole

FT

* Unidades en milímetros.
Units in millimeters.

Referencia Reference	ØD	ØB	ØK	L	T	S	N	Peso Weight Kgs.
FT0114	14.25	40	32	35	17	32	3	0.45
FT0116	16.25	40	32	35	17	32	3	0.40
FT0216	16.25	50	40	44	22	41	3	0.85
FT0220	20.50	50	40	44	22	41	3	0.75
FT0320	20.50	55	45	44	22	41	3	1.05
FT0420	20.50	60	50	50	25	47	3	1.35
FT0425	25.50	60	50	50	25	47	3	1.20
FT0525	25.50	65	55	50	25	47	3	1.40
FT0625	25.50	70	60	50	25	47	3	1.65
FT0725	25.50	75	65	58	29	55	3	2.05
FT0830	30.50	80	70	58	29	55	3	2.40
FT0930	30.50	90	80	58	29	55	3	3.10
FT1030	30.50	95	80	58	29	55	3	3.80
FT1130	30.50	100	90	60	29	57	3	3.90
FT1230	30.50	105	90	60	29	57	3	4.80
FT1330	30.50	115	100	66	29	60	6	5.60
FT1440	40.50	140	120	82	35	76	6	9.40
FT1560	60.50	150	130	108	50	100	8	13.50

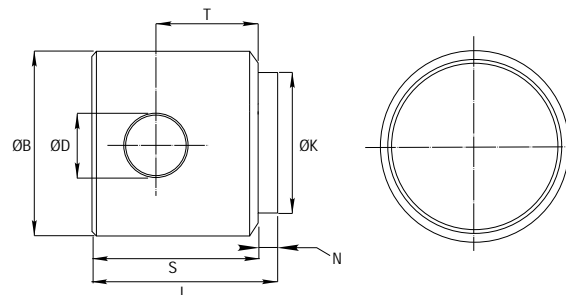

Material en S152.3 / Material in S152.3.
Otras medidas bajo pedido / Others measures on request.

Charnela estándar

Male clevis

CRB

Referencia Reference	ØD	M	T	L	R	Peso Weight Kgs.
CRB0216	16	35	25	42	16	0.15
CRB0220	20	35	25	42	20	0.20
CRB0225	25	50	35	60	25	0.30
CRB0230	30	60	40	70	30	0.55
CRB0240	30	70	45	80	35	1.15
CRB0250	40	80	55	95	40	2.35

* Unidades en milímetros.
Units in millimeters.

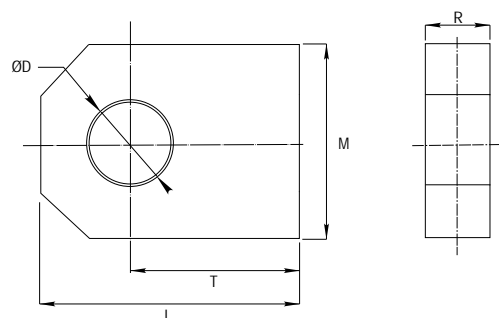

*Material en S152.3 / Material in S152.3.
*Otras medidas bajo pedido / Others measures on request.

Rótula esférica TPR/N Din648

Ball joint TPR/N Din 648

TPR..N

Referencia Reference	ØD	B	G	L	T	M	R	Peso Weight Kgs.
TPR220N	20	56	41	78	50	M16X1.5	19	0.43
TPR225N	25	56	41	78	50	M16X1.5	23	0.48
TPR230N	30	64	46	92	60	M22X1.5	28	0.74
TPR235N	35	78	58	109	70	M28X1.5	30	1.20
TPR240N	40	94	66	132	85	M35X1.5	35	2.00
TPR250N	50	116	88	163	105	M45X1.5	40	3.80

* Unidades en milímetros.
Units in millimeters.

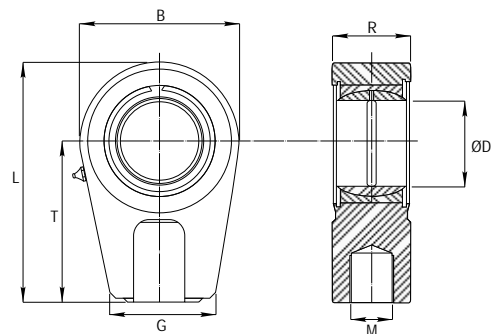

Superficie de contacto: acero/acero - Contact surface: steel/steel.
Equivalente / Equivalent INA GIHR...DO
Equivalente / Equivalent SKF SIRD...ES

Rótula esférica TPR/U Din648

Ball joint TPR/U Din 648

TPR..U

Referencia Reference	ØD	B	G	L	T	M	R	Peso Weight Kgs.
TPR220U	20	56	41	78	50	M16X1.5	19	0.43
TPR225U	25	56	41	78	50	M16X1.5	23	0.48
TPR230U	30	64	46	92	60	M22X1.5	28	0.74
TPR235U	35	78	58	109	70	M28X1.5	30	1.20
TPR240U	40	94	66	132	85	M35X1.5	35	2.00
TPR250U	50	116	88	163	105	M45X1.5	40	3.80

* Unidades en milímetros.
Units in millimeters.

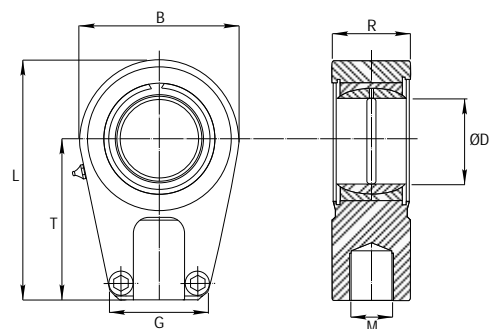

Superficie de contacto: acero/acero - Contact surface: steel/steel.
Equivalente / Equivalent INA GIHR-K...DO
Equivalente / Equivalent SKF SIR...ES

Rótula radial GE

Radial ball joint GE

GE..X

Referencia Reference	ØD	ØB	G	L	Peso Weight Kgs.
GE215X	15	26	11	13	0.03
GE220X	20	32	14	16	0.05
GE225X	25	42	18	21	0.12
GE230X	30	50	23	27	0.23
GE235X	35	55	26	30	0.30
GE240X	40	62	28	33	0.38
GE245X	45	72	31	36	0.60
GE250X	50	80	36	42	0.87

* Unidades en milímetros.
Units in millimeters.

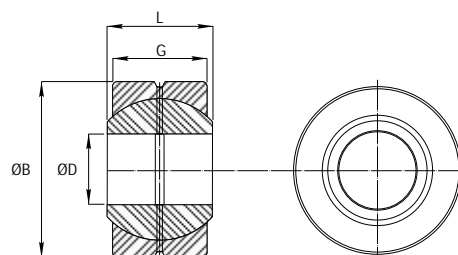

Superficie de contacto: acero/acero - Contact surface: steel/steel.
Equivalente / Equivalent INA GE...DO
Equivalente / Equivalent SKF GE...ES

Rótula esférica soldable Din648

Weldable ball joint Din648

TAC

Referencia Reference	ØD	ØB	ØG	L	T	M	R	Peso Weight Kgs.
TAC0215	15	40	21	51	31	10	12	0.12
TAC0220	20	53	28	65	38	13	16	0.23
TAC0225	25	64	34	77	45	17	20	0.43
TAC0230	30	73	40	88	51	19	22	0.64
TAC0235	35	82	47	102	61	21	25	0.96
TAC0240	40	92	52	115	69	23	28	1.30
TAC0245	45	102	58	128	77	27	32	1.80
TAC0250	50	112	62	144	88	30	35	2.50

* Unidades en milímetros.
Units in millimeters.

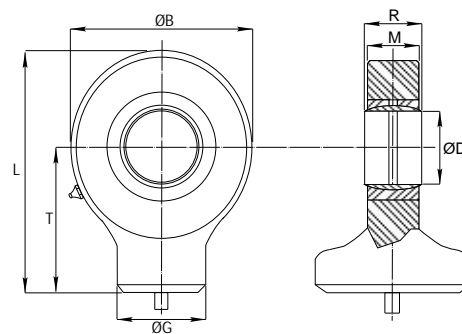

Superficie de contacto: acero/acero - Contact surface: steel/steel.
Equivalente / Equivalent INA GK...DO
Equivalente / Equivalent SKF SC...ES

Rótula esférica TPN Din648

Sferic ball join TPN Din648

TPN

Referencia Reference	ØD	B	G	L	T	Peso Weight Kgs.
TPN320	20	50	20	63	38	0.35
TPN325	25	55	24	73	45	0.55
TPN330	30	65	29	83	51	0.90
TPN335	35	83	31	102	61	1.50
TPN340	40	100	36	119	69	2.40
TPN345	45	110	41	132	77	3.40
TPN350	50	123	41	150	88	4.40

* Unidades en milímetros.
Units in millimeters.

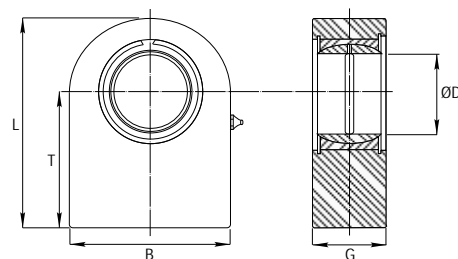

Superficie de contacto: acero/acero - Contact surface: steel/steel.
Equivalente / Equivalent INA GF...DO
Equivalente / Equivalent SKF SCF...DO

Base oscilante

Swinging end

BSK

Referencia Reference	ØD	ØB	T	L	ØR	Peso Weight Kgs.
BSK085	50	40	20	82	85	2.20
BSK098	60	50	25	100	98	3.40
BSK105	70	60	30	115	105	4.82

* Unidades en milímetros.
Units in millimeters.

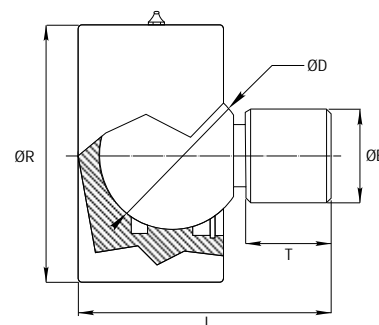

Base oscilante soldable / Weldable swinging end.
Roscada bajo pedido / On request threaded.

Horquilla mecanizada (roscada)

Machining fork (threaded)

FR

Referencia Reference	ØD	G	B	L	T	M	R	S	Peso Weight Kgs.
FR0216	16.20	M16x1.5	16	55	39	24	16	35	0.12
FR0220	20.25	M20x1.5	20	65	45	30	20	40	0.23
FR0225	25.25	M24x2.0	25	70	50	30	20	50	0.43
FR0230	30.25	M30x2.0	30	90	65	35	25	60	0.64
FR0235	35.25	M33x2.0	35	105	75	40	30	70	0.96

* Unidades en milímetros.
Units in millimeters.

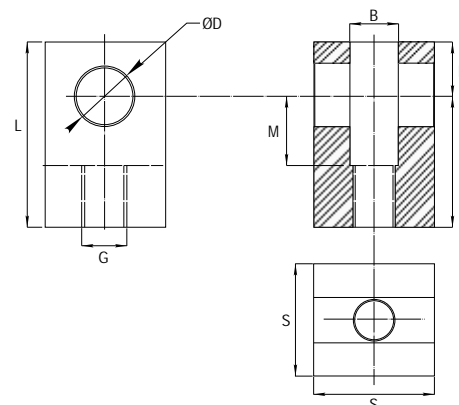

Material en St52.3 / Material in St52.3.
Roscada / Threaded.

Horquilla mecanizada (soldable)

Machining fork (Weldable)

FS

Referencia Reference	ØD	B	L	T	M	R	S	Peso Weight Kgs.
FS0216	16.20	16	55	39	24	16	35	0.12
FS0220	20.25	20	65	45	30	20	40	0.23
FS0225	25.25	25	70	50	30	20	50	0.43
FS0230	30.25	30	90	65	35	25	60	0.64
FS0235	35.25	35	105	75	40	30	70	0.96

* Unidades en milímetros.
Units in millimeters.

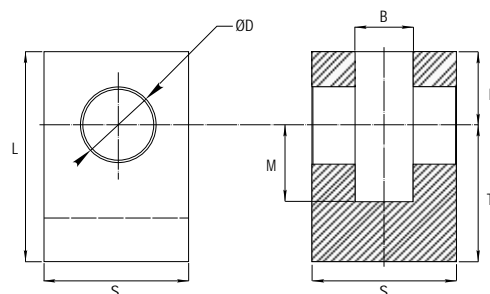

Material en St52.3 / Material in St52.3.
Soldable / Weldable.

Arrastrador macho

Plain rod eye

FK

Referencia Reference	Y	ØA	B	C	D	K	F	G	H	I	J	Peso Weight Kgs.
FK032	M12x1.25	12	16	16	31	18	26	34	13	6	47	2.20
FK040	M16x1.50	16	20	24	41	22	32	49	16	8	65	3.40
FK050	M20x1.50	20	25	28	48	26	40	56	20	10	76	4.82
FK060	M27x2.00	25	32	35	57	33	50	67	25	15	92	2.20
FK070	M27x2.00	25	32	35	57	33	50	67	25	15	92	3.40
FK080	M33x2.00	32	40	44	77	42	65	89	32	17	121	4.82
FK090	M33x2.00	32	40	44	77	42	65	89	32	17	121	3.40
FK100	M42x2.00	40	50	54	95	52	80	109	40	20	149	4.82

* Unidades en milímetros.
Units in millimeters.

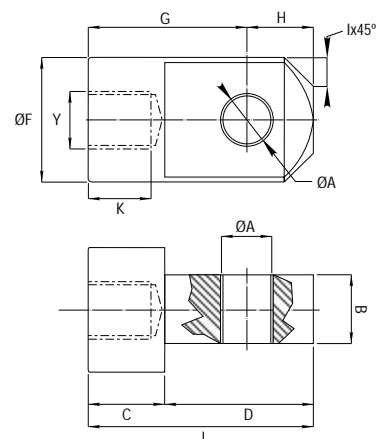

Superficie pavonada / Blued surface.
Casquillo interior en bronce / Inside bush in bronze.

Rótula agrícola soldable

Weldable ball joint

TNC

Referencia Reference	ØD	B	ØG	L	T	R	Peso Weight Kgs.
TNC0115	19.30	60	34	51	60	44	0.12
TNC0116	20.50	40	21	51	31	12	0.12
TNC0120	25.40	53	28	65	38	16	0.23
TNC0124	25.40	64	34	77	45	20	0.43
TNC0128	30.20	73	40	88	51	22	0.64
TNC0132	35.20	82	47	102	61	25	0.96
TNC0134	40.20	92	52	115	69	28	1.30
TNC0138	45.20	102	58	128	77	32	1.80
TNC0142	50.20	112	62	144	88	35	2.50

* Unidades en milímetros.
Units in millimeters.

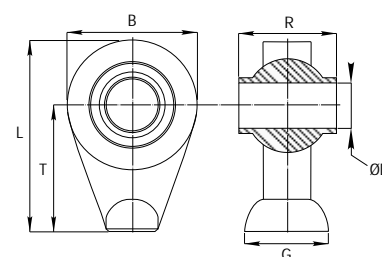

Superficie de contacto: acero-acero / Contact surface : steel-steel.
Tratamiento zinc trivalente / Zinc trivalent treatment.

Enganche rápido (hembra)

Rapid hook (female)

EPS

Referencia Reference	Cat.	ØD	ØB	T	L	Peso Weight Kgs.
EPS2050	2	50	M30X2.0	35	102	2.30
EPS3060	3	60	M36X2.0	40	132	4.04

* Unidades en milímetros.
Units in millimeters.

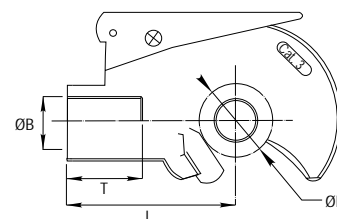

Superficie de contacto: acero-acero / Contact surface : steel-steel.
Tratamiento zinc trivalente / Zinc trivalent treatment.
El enganche rápido se suministra sin bola / Rapid hook is supplied without ball.

Enganche rápido (macho)

Rapid hook (male)

EPM

Referencia Reference	Cat.	ØD	ØB	T	L	Peso Weight Kgs.
EPM2050	2	50	M30X3.0	180	102	3.40
EPM3060	3	60	M36X3.0	180	132	5.78

* Unidades en milímetros.
Units in millimeters.

Cadena enganche rápido

Rapid hook chain

Referencia Reference	Longitud Lenght	Peso Weight Kgs.
CH0150	1.500	0.00
CH0200	2.000	0.00

* Unidades en milímetros.
Units in millimeters.

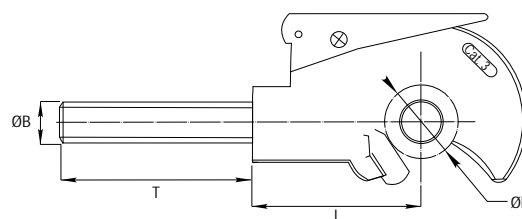

Superficie de contacto: acero-acero / Contact surface : steel-steel.
Tratamiento zinc trivalente / Zinc trivalent treatment.
El enganche rápido se suministra sin bola / Rapid hook is supplied without ball.

Bola de enganche rápido

Rapid hook ball

GA..X

Referencia Reference	ØB	ØD	L	Peso Weight Kgs.
GA216X	50	19	44	0.34
GA220X	50	19	51	0.42
GA225X	50	22	51	0.47
GA230X	50	25	44	0.34
GA235X	50	25	51	0.35
GA240X	50	30	51	0.44
GA245X	60	25	51	0.64
GA250X	60	28	51	0.59
GA255X	60	32	51	0.56

* Unidades en milímetros.
Units in millimeters.

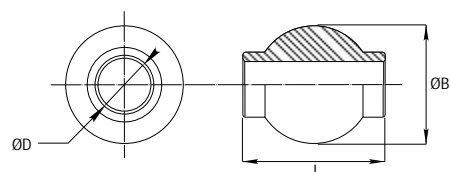

Bola para enganche rápido EPS y EPM (página 24).
Ball for rapid hook EPS and EPM (page 24).
Tratamiento zinc trivalente.
Zinc trivalent treatment.

Rótula agrícola roscada

Threaded ball join

RPS

Referencia Reference	Cat.	ØD	M	ØP	S	L	T	K	Peso Weight Kgs.
RPS3355	1	19	M30X2.0	62	175	225	55	44	1.36
RPS4400	2	25	M30X2.0	75	165	220	55	51	1.62

* Unidades en milímetros.
Units in millimeters.

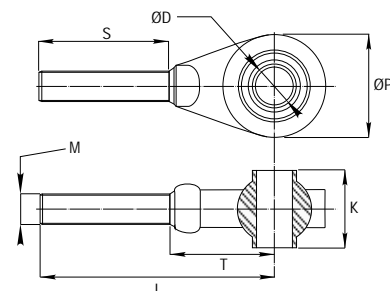

Rótula roscada para cilindro tercer punto Serie 600 (página 14).
Ball for hydraulic top link 600 series (page 14).
Tratamiento zinc trivalente.
Zinc trivalent treatment.

Horquilla estándar (plegada)

Standard fork (folded)

KX

Referencia Reference	ØD	B	G	L	T	M	K	N	Peso Weight Kgs.
KX0216	16	32	16	47	33	14	35	8	0.43
KX0220	20	36	20	51	35	16	40	8	0.48
KX0225	25	45	25	62	40	22	45	10	0.74
KX0230	30	60	30	75	50	25	60	15	1.20
KX0235	35	65	35	85	55	30	70	15	2.00
KX0240	40	80	40	95	60	35	80	20	3.80

* Unidades en milímetros.
Units in millimeters.

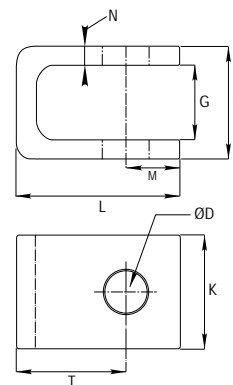

Material en S152.3 / Material in S152.3.
Otras medidas bajo pedido / Other measures on request.

Fondo estándar

Standard End-plug

FE

Referencia Reference	ØB	ØG	T	M	N	Peso Weight Kgs.
FE0116	40	32	10	13	3	0.40
FE0220	50	40	15	18	3	0.75
FE0320	55	45	15	18	3	1.05
FE0425	60	50	15	18	3	1.20
FE0525	65	55	15	18	3	1.40
FE0625	70	60	15	18	3	1.65
FE0725	75	65	15	18	3	2.05
FE0830	80	70	15	18	3	2.40
FE0930	90	80	15	18	3	3.10
FE1030	95	80	15	18	3	3.80
FE1130	100	90	15	18	3	3.90
FE1230	105	90	15	18	3	4.80
FE1330	115	100	20	26	6	5.60
FE1440	140	120	20	26	6	9.40
FE1560	150	130	20	28	8	13.50

* Unidades en milímetros.
Units in millimeters.

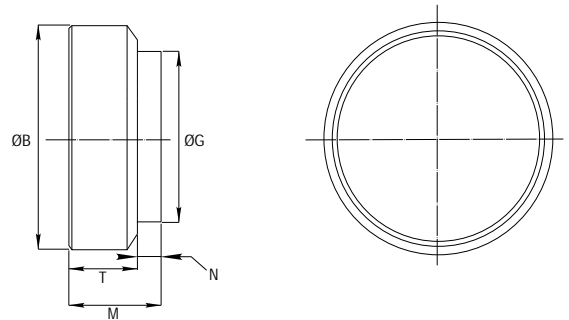

Material en SI52.3 / Material in SI52.3.
Otras medidas bajo pedido / Other measures on request.

Fondo XR

End-plug XR

XR

Referencia Reference	ØB	ØG	ØD	L	R	S	F	M	N	Z	Peso Weight Kgs.
XR0800	80	70	28.20	52	15	60	25	76	3.0	40	3.15
XR0950	95	80	28.20	52	15	60	25	76	3.0	40	4.40
XR1050	105	90	28.20	52	15	60	25	76	3.0	40	5.40
XR1150	115	100	28.20	52	15	60	25	79	6.0	40	6.60

* Unidades en milímetros.
Units in millimeters.

Fondo diseñado para articulación americana ATP (página 28).
End design for ATP articulated yoke (page 28).

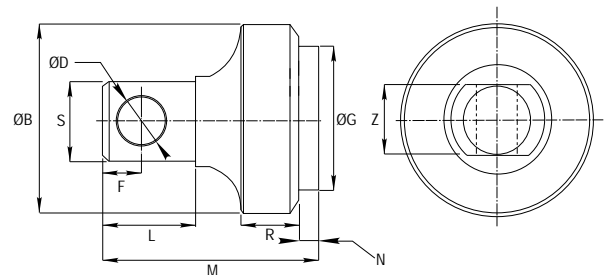

Material en SI52.3 / Material in SI52.3.
Otras medidas bajo pedido / Other measures on request.

Fondo XS

End-plug XS

XS

Referencia Reference	ØB	ØG	ØS	L	P	M	N	Peso Weight Kgs.
XS0600	60	50	30.00	15	5	23	3.0	0.70
XS0700	70	60	40.00	20	15	38	3.0	1.25
XS0800	80	70	50.00	20	15	38	3.0	1.65
XS0900	90	80	50.00	20	15	38	6.0	2.30
XS0950	95	80	50.00	20	15	38	3.0	2.45
XS1050	105	90	50.00	22	15	40	3.0	3.25
XS1150	115	100	50.00	22	15	43	6.0	3.75

* Unidades en milímetros.
Units in millimeters.

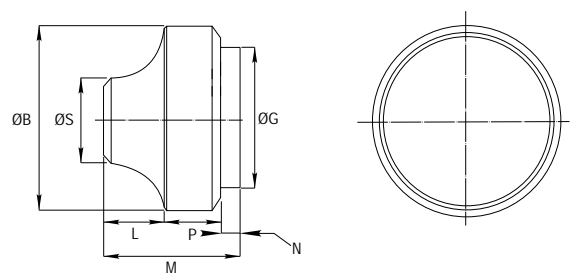

Fondo diseñado para rótulas TNC (página 24).
End design for TNC ball joint (page 24).
Material en SI52.3 / Material in SI52.3.

Fondo XT End-plug XT

XT

Referencia Reference	ØB	ØG	ØK	ØS	L	R	P	M	N	Peso Weight Kgs.
XT0800	80	70	M30x3	50	100	15	100	118	3.0	2.15
XT0950	90	80	M36x3	50	100	15	100	118	3.0	2.80
XT1050	95	80	M36x3	60	100	15	100	118	3.0	3.15
XT1150	105	90	M36x3	60	100	15	100	121	6.0	3.65

* Unidades en milímetros.
Units in millimeters.

Fondo diseñado para rótulas RPS y articulaciones ATP (ajustable).
End design for ball joints RPS and articulated yokes ATP (adjustable).

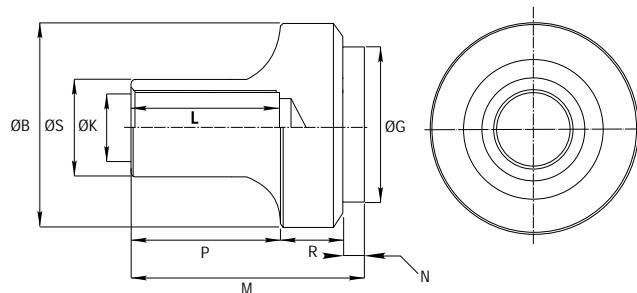

Culote con rótula fundición SW Weld-on ball end SW

SW

Referencia Reference	ØB	ØG	ØK	ØD	L	R	P	M	N	Peso Weight Kgs.
SW0700	70	60	85	25.40	105	10	51	150	2.0	2.00
SW0800	80	70	85	25.40	105	10	51	150	2.0	2.30
SW0950	95	80	85	25.40	105	10	51	150	2.0	2.65
SW0960	95	80	85	32.20	108	10	51	150	2.0	2.55
SW1050	105	90	85	25.40	108	10	51	150	2.0	3.05

* Unidades en milímetros.
Units in millimeters.

Material en St52.3 / Material in St52.3.
Superficie protegida contra la corrosión / Protected surface against corrosion.

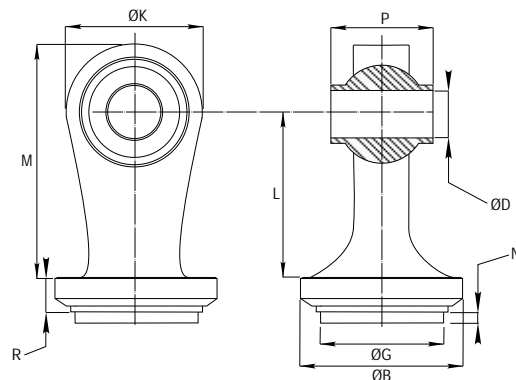

Culote forjado SZ Forged end SZ

SZ

Referencia Reference	ØB	ØG	ØK	ØD	L	R	P	M	N	Peso Weight Kgs.
SZ0850	80	70	50	28.20	90	18	39	100	4.5	2.50
SZ0900	90	80	50	28.20	90	18	39	100	4.5	2.55
SZ1050	105	90	50	28.20	88	18	39	102	4.5	2.65

* Unidades en milímetros.
Units in millimeters.

Material en St52.3 / Material in St52.3.
Superficie protegida contra la corrosión / Protected surface against corrosion.

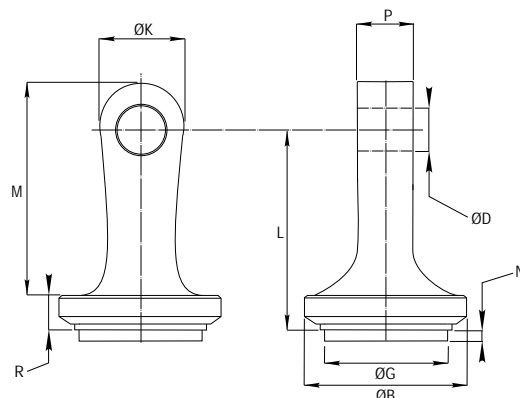

Brida estándar BR

Standard flange BR

BR

Referencia Reference	ØB	ØM	T	ØL	ØD	Peso Weight Kgs.
BRL0400	80	39	10.00	67	7.00	0.15
BRL0500	100	49	12.00	82	9.00	0.20
BRL0600	125	59	12.00	103	11.00	0.30
BRL0700	145	69	12.00	120	13.00	7.00
BRL0800	170	79	15.00	142	15.00	7.00
BRL0900	170	89	15.00	142	15.00	7.00
BRL1000	202	99	15.00	170	17.00	0.15
BRP0750	145	74	24.00	120	13.00	0.20
BRP0850	170	84	24.00	142	15.00	0.30
BRP0950	170	94	24.00	142	15.00	7.00
BRP1050	202	104	24.00	170	17.00	7.00
BRP1150	202	114	28.00	170	17.00	7.00
BRP1400	250	138	30.00	210	21.00	7.00
BRP1500	280	148	30.00	230	21.00	7.00

* Unidades en milímetros.
Units in millimeters.

BRL Brida Serie ligera / Light flange series.
BRP Brida Serie pesada / Heavy duty flange series.

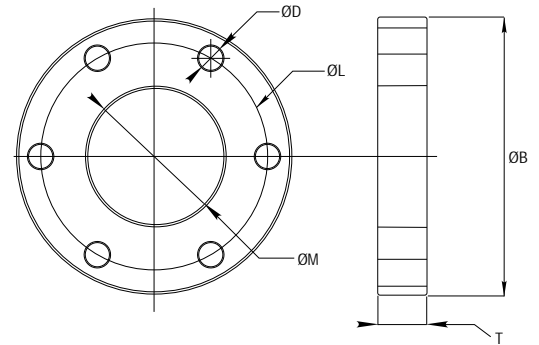

*Material en S152.3 / Material in S152.3.

Muñón MS

Weld on trunnion MS

MS

Referencia Reference	ØD	ØB	T	L	M	N	Peso Weight Kgs.
MS0500	25	65	15	95	50	29	0.15
MS0600	30	75	20	115	60	34	0.20
MS0700	30	90	20	130	70	34	0.30
MS0800	40	105	30	165	80	54	7.00
MS0850	40	105	30	165	85	54	7.00
MS0900	45	120	35	190	90	58	7.00
MS0950	45	120	35	190	95	58	0.30
MS1000	45	130	35	200	100	58	7.00
MS1050	45	130	35	200	105	58	7.00
MS1150	50	145	40	225	115	68	7.00

* Unidades en milímetros.
Units in millimeters.

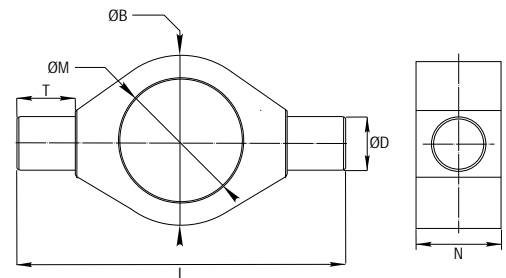

*Material en S152.3 / Material in S152.3.

Cruceta articulada ATP

Articulated yoke ATP

ATP

Referencia Reference	ØD	ØB	M	L	P	N	Peso Weight Kgs.
ATP0219	19.40	28.20	63	87	40	50	2.15
ATP0220	20.40	28.20	63	87	40	50	2.12
ATP0222	22.40	28.20	63	87	40	50	2.10
ATP0225	25.40	28.20	63	87	40	50	2.05
ATP0228	28.40	28.20	63	87	40	50	1.98
ATP0230	30.40	28.20	63	87	40	50	1.95
ATP0232	32.40	28.20	63	87	40	50	1.90

* Unidades en milímetros.
Units in millimeters.

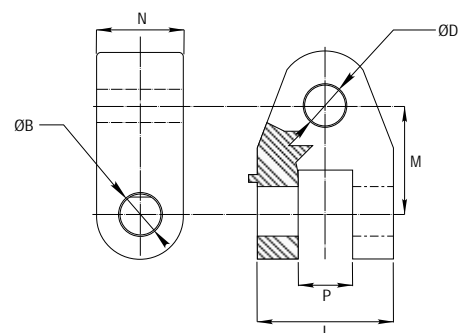

*Tratamiento zinc trivalente / Zinc trivalent treatment.

Blocador PS

Top link locking collars PS

PS

Referencia Reference	ØD	ØM	T	L	Peso Weight Kgs.
PS0205	80	39	10.00	67	0.15
PS0210	100	49	12.00	82	0.20

* Unidades en milímetros.
Units in millimeters.

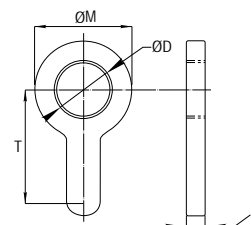

* Tratamiento zinc trivalente / Zinc trivalent treatment.

Perno articulación ATP

ATP pin articulated yoke

PA

Referencia Reference	ØD	ØB	T	L	M	N	Peso Weight Kgs.
PA0500	25	65	15	95	50	29	0.15

* Unidades en milímetros.
Units in millimeters.

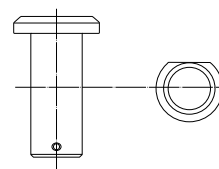

Perno roscado articulación PR

Threaded pin articulated yoke PR

PR

Referencia Reference	ØD	ØB	T	L	M	N	Peso Weight Kgs.
PA0500	25	65	15	95	50	29	0.15

* Unidades en milímetros.
Units in millimeters.

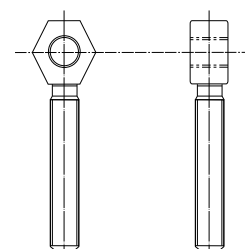

Tuerca exagonal soldable TAX

Exagonal nut TAX

TAX

Referencia Reference	ØD	ØB	T	L	M	N	Peso Weight Kgs.
PA0500	25	65	15	95	50	29	0.15

* Unidades en milímetros.
Units in millimeters.

** Tuerca soldable para tercer punto Serie 600.
Calidad material : S152.3.

** Lock nuts for Series 600 hydraulic top link.
Material grade: S152.3.

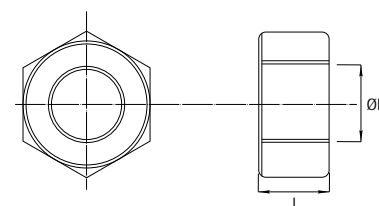

Cabeza guía CGSE

Head bush CGSE

CGSE

Referencia Reference	ØA	ØB	ØC	ØM	L	N	Peso Weight Kgs.
CGSE032025	25	32	32	37x1.5	33	8	0.45
CGSE040030	30	40	40	45x2.0	42	7	0.60
CGSE045035	35	45	45	45x2.0	42	7	0.85
CGSE050040	40	50	50	55x2.0	44	8	1.35
CGSE050045	45	50	50	55x2.0	44	8	1.25
CGSE055050	50	55	55	55x2.0	44	8	1.20
CGSE060055	55	60	60	65x2.0	47	8	1.95
CGSE065060	60	65	65	65x2.0	47	8	1.85
CGSE080070	70	80	80	65x2.0	47	8	1.70
CGSE100090	90	100	100	65x2.0	47	8	1.55

* Unidades en milímetros.
Units in millimeters.

Características:

- * Material en DIN C45.
- * Cabeza guiada.
- * Posibilidad de intercambiar guías:
Resistencia al esfuerzo radial:
Resina acetil 30N/mm².
Resina fenólica 300N/mm².
- * Collarín: Labios asimétricos 90 shores.
- * Rascador metálico
- * Junta tórica 90 shores.

Technical data:

- * Material in DIN C45.
- * Guided head.
- * Ability of change guides:
Radial stress resistance:
Acetal resine 30N/mm².
Phenolic resine 300N/mm².
- * Rod seal: 90 shores asymmetrical lips.
- * Metal wiper
- * O-ring : 90 shores.

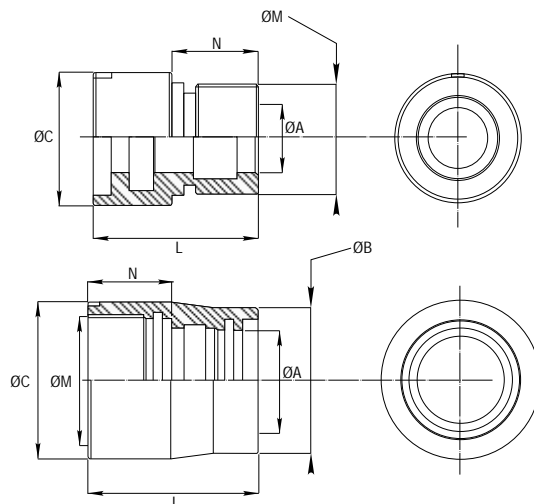

Cabeza guía CGDE

Head bush CGDE

CGDE

Referencia Reference	ØA	ØB	ØC	ØM	L	N	Peso Weight Kgs.
CGDE032020	20	32	40	37x1.5	33	8	0.45
CGDE040020	20	40	50	45x2.0	42	7	0.60
CGDE040025	25	40	50	45x2.0	42	7	0.85
CGDE050025	25	50	60	55x2.0	44	8	1.35
CGDE050030	30	50	60	55x2.0	44	8	1.25
CGDE050035	35	50	60	55x2.0	44	8	1.20
CGDE060025	25	60	70	65x2.0	47	8	1.95
CGDE060030	30	60	70	65x2.0	47	8	1.85
CGDE060035	35	60	70	65x2.0	47	8	1.70
CGDE060040	40	60	70	65x2.0	47	8	1.55
CGDE070035	35	70	80	75x2.0	51	10	2.85
CGDE070040	40	70	80	75x2.0	51	10	2.45
CGDE070045	45	70	80	75x2.0	51	10	2.25
CGDE070050	50	70	80	75x2.0	51	10	2.00
CGDE080035	35	80	90	85x2.0	56	10	0.30
CGDE080040	40	80	90	85x2.0	56	10	7.00
CGDE080045	45	80	90	85x2.0	56	10	7.00
CGDE080050	50	80	90	85x2.0	56	10	7.00
CGDE090040	40	90	100	95x2.0	60	10	0.15
CGDE090045	45	90	100	95x2.0	60	10	0.20
CGDE090050	50	90	100	95x2.0	60	10	0.20
CGDE090060	60	90	100	95x2.0	60	10	0.30
CGDE100050	50	100	115	106x2.0	66	15	7.00
CGDE100060	60	100	115	106x2.0	66	15	7.00

* Unidades en milímetros.
Units in millimeters.

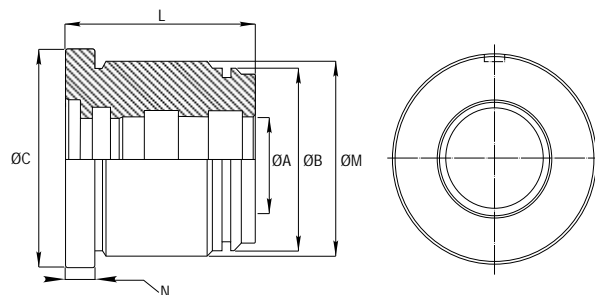

Características:

- * Material en DIN C45.
- * Cabeza guiada.
- * Posibilidad de intercambio guías :
Resistencia al esfuerzo radial:
Resina acetil 30N/mm².
Resina fenólica 300N/mm².
- * Collarín: Doble labio compacto 93 shores.
- * Rascador metálico
- * Junta tórica 90 shores.

Technical data:

- * Material in DIN C45.
- * Guided head.
- * Ability of change guides :
Radial stress resistance:
Acetal resine 30N/mm².
Phenolic resine 300N/mm².
- * Rod seal: Compact double lip 93 shores.
- * Metal wiper
- * O-ring : 90 shores.

Referencia Reference	ØA	ØB	ØC	ØM	L	N	Peso Weight Kgs.
CGDE100070	70	100	115	106x2.0	66	15	7.00
CGDE120060	60	120	140	126x2.0	68	15	0.60
CGDE120070	70	120	140	126x2.0	68	15	0.85
CGDE120080	80	120	140	126x2.0	68	15	1.35
CGDE130070	70	130	150	136x2.0	75	15	1.25
CGDE130080	80	130	150	136x2.0	75	15	1.20
CGDE130090	90	130	150	136x2.0	75	15	1.95

Pistón estándar OTD

Standard piston OTD

OTD

Referencia Reference	ØA	ØB	ØS	ØT	K	Q	L	Peso Weight Kgs.
OTD032016	32	16	24	28.00	3.20	15.50	25	0.45
OTD040016	40	16	32	36.00	3.20	15.50	35	0.60
OTD040022	40	22	32	36.00	3.20	15.50	35	0.85
OTD050022	50	22	38	46.00	4.20	20.50	35	1.35
OTD050026	50	26	38	46.00	4.20	20.50	35	1.25
OTD060022	60	22	48	56.00	4.20	20.50	35	1.20
OTD060026	60	26	48	56.00	4.20	20.50	35	1.95
OTD070026	70	26	58	66.00	4.20	20.50	36	1.85
OTD070032	70	32	58	66.00	4.20	20.50	36	1.70
OTD080026	80	26	66	86.00	5.20	22.50	44	1.55
OTD080032	80	32	66	86.00	5.20	22.50	44	2.85
OTD090032	90	32	76	96.00	5.20	22.50	44	2.45
OTD100040	100	40	86	96.00	5.20	22.50	47	1.85
OTD120040	120	40	106	116.00	5.20	22.50	47	1.70
OTD130060	130	60	105	122.60	9.52	25.40	60	1.55

* Unidades en milímetros.
Units in millimeters.

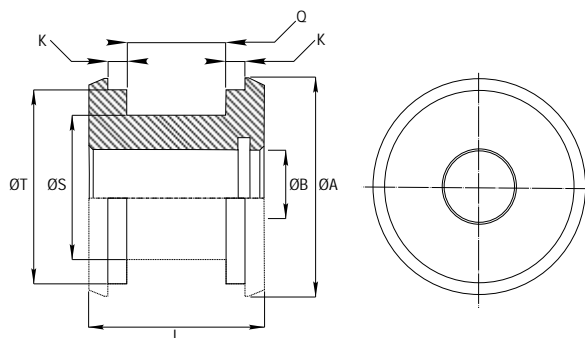

Material en DIN C45 / Material in DIN C45.
Montaje pistón modo : DPS (3 piezas) y DAS (5 piezas).
Mounting mode : DPS (3 pieces) and DAS (5 pieces).

Pistón roscado OTR

Threaded piston OTR

OTR

Referencia Reference	ØA	ØB	ØS	ØT	ØM	K	Q	L	Peso Weight Kgs.
OTR032012	32	16	24	28.00	M12x1.5	3.20	15.50	25	0.45
OTR040016	40	20	32	36.00	M16x1.5	3.20	15.50	35	0.60
OTR050020	50	25	38	46.00	M20x1.5	4.20	20.50	35	0.85
OTR060020	60	25	48	56.00	M20x1.5	4.20	20.50	35	1.35
OTR070030	70	35	58	66.00	M30x2.0	4.20	20.50	36	1.25
OTR080030	80	35	66	76.00	M30x2.0	5.20	22.50	44	1.20
OTR090030	90	35	76	86.00	M30x2.0	5.20	22.50	44	1.95
OTR100030	100	35	86	96.00	M30x2.0	5.20	22.50	47	1.85
OTR120040	120	45	106	116.00	M40x2.0	5.20	22.50	47	1.70
OTR130040	130	45	105	122.60	M40x2.0	9.52	25.40	60	1.55

* Unidades en milímetros.
Units in millimeters.

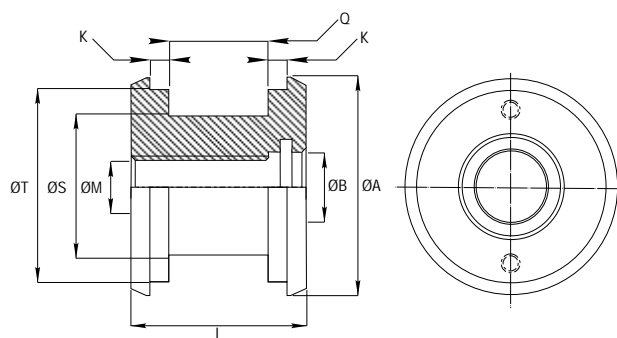

Material en DIN C45 / Material in DIN C45.
Montaje pistón modo : DPS (3 piezas) y DAS (5 piezas).
Mounting mode : DPS (3 pieces) and DAS (5 pieces).

Pistón OTX

Piston OTX

OTX

Referencia Reference	ØA	ØB	ØS	ØT	ØM	K	Q	L	Peso Weight Kgs.
OTX070030	70	35	54.50	65.00	M30x2.0	9.65	6.30	57	0.45
OTX080030	80	35	64.50	75.00	M30x2.0	9.65	6.30	57	0.60
OTX090040	90	45	74.50	85.00	M40x2.0	9.65	6.30	65	0.85
OTX100040	100	45	79.00	95.00	M40x2.0	9.65	8.10	65	1.35
OTX120050	120	55	99.00	115.00	M50x2.0	15.00	8.10	85	1.25
OTX130050	130	55	109.00	125.00	M50x2.0	15.00	8.10	85	1.20

* Unidades en milímetros.
Units in millimeters.

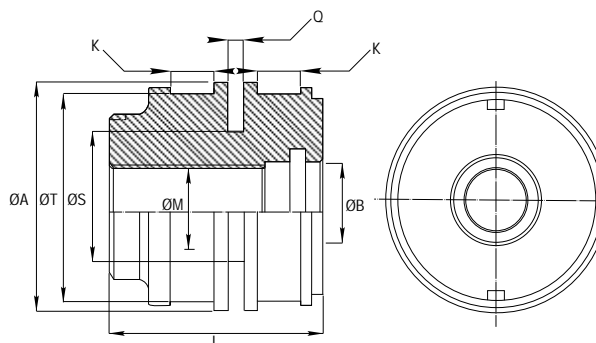

Material en DIN C45 / Material in DIN C45.
Montaje pistón modo : Wynseal (Poliuretano). - Glydring Tf+Bz
Mounting mode : Wynseal (Polyurethane). - Glydring Tf+Bz

Tuerca autoblocante Din985 Nylon lock nut Din985

TAB

Referencia Reference	ØD	L	Metrica Metric	Peso Weight Kgs.
TAB014150	14	14	1.50	0.00
TAB020150	20	20	1.50	0.00
TAB024200	24	24	2.00	0.00
TAB030200	30	30	2.00	0.00
TAB039300	39	39	3.00	0.00

* Unidades en milímetros.
Units in millimeters.

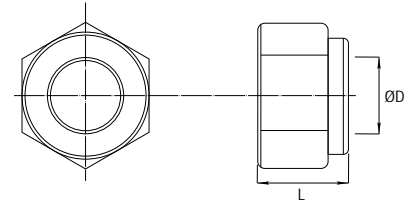

Normativa Din985 / Norm Din985.
Tratamiento zinc-plata / Zinc trivalent treatment.
Acero 8.8 / Steel 8.8.

Racor alimentación (hembra) Threaded port (female)

RSH

Referencia Reference	ØD	ØB	L	Peso Weight Kgs.
RSH02016	20	1/8"	16	0.00
RSH04016	20	1/4"	16	0.00
RSH04035	20	1/4"	35	0.00
RSH08016	25	3/8"	16	0.00
RSH08040	25	3/8"	40	0.00
RSH10020	30	1/2"	20	0.00
RSH10045	30	1/2"	45	0.00
RSH12020	38	3/4"	20	0.00

* Unidades en milímetros.
Units in millimeters.

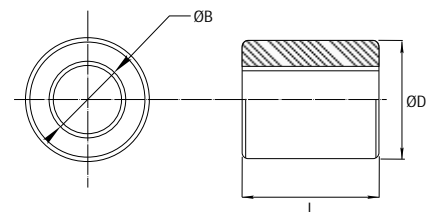

Acero C15 / Steel C15.
Buena soldabilidad / Good weldability.

Racor alimentación (macho) Threaded port (male)

RSM

Referencia Reference	ØD	ØB	L	Peso Weight Kgs.
RSM02020	1/8"	4.0	20	0.00
RSM04024	1/4"	6.0	24	0.00
RSM06024	3/8"	8.0	24	0.00
RSM08030	1/2"	11.0	30	0.00
RSM10035	3/4"	14.0	35	0.00

* Unidades en milímetros.
Units in millimeters.

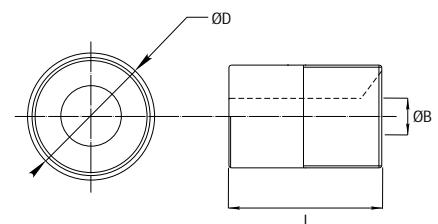

Acero C15 / Steel C15.
Buena soldabilidad / Good weldability.

Racor alimentación para tubo

Threaded port for pipe

RTH

Referencia Reference	ØD	ØB	T	L	Peso Weight Kgs.
RTH02050	25	12	1/4	50	0.00
RTH04050	25	12	3/8	50	0.00
RTH06055	30	15	1/2	55	0.00

* Unidades en milímetros.
Units in millimeters.

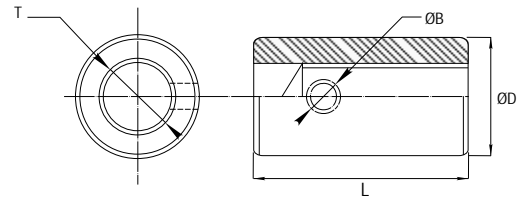

Acero C15 / Steel C15.
Buena soldabilidad / Good weldability.

Racor alimentación doble

Double threaded port

RTX

Referencia Reference	ØD	ØB	T	L	P	Peso Weight Kgs.
RTX02015	1/4"	12	50.00	70	30.00	0.00
RTX04016	3/8"	14	50.00	80	30.00	0.00
RTX06016	1/2"	15	60.00	90	40.00	0.00

* Unidades en milímetros.
Units in millimeters.

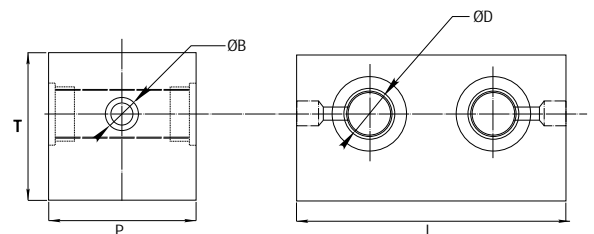

Acero C15 / Steel C15.
Buena soldabilidad / Good weldability.

Esférico estándar

Standard banjo

RR

Referencia Reference	ØD	ØB	T	L	ØR	Peso Weight Kgs.
RR02015	1/4"	22	14.50	44	12.00	0.07
RR04016	3/8"	22	17.00	39	12.00	0.07
RR06016	1/2"	27	22.00	45	15.00	0.14

* Unidades en milímetros.
Units in millimeters.
Se suministra con tuerca y bicono / Supplied with nut and bicone.
Acero C15 / Steel C15.

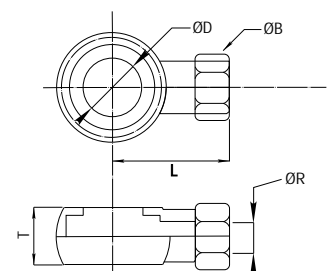

Esférico prensado corto

Short pressing banjo

RC

Referencia Reference	ØD	ØB	T	L	ØR	Peso Weight Kgs.
RC02015	1/4"	22	14.50	44	12.00	0.04
RC04016	3/8"	22	17.00	39	12.00	0.05
RC06016	1/2"	27	22.00	45	15.00	0.09

* Unidades en milímetros.
Units in millimeters.

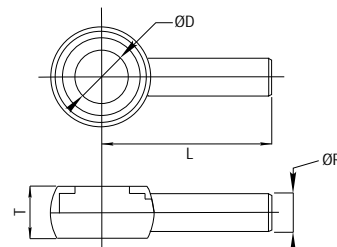

Esférico prensado medio

Medium pressing banjo

RM

Referencia Reference	ØD	ØB	T	L	ØR	Peso Weight Kgs.
RM02015	1/4"	22	14.50	112	12.00	0.08
RM04016	3/8"	22	17.00	106	12.00	0.08
RM06016	1/2"	27	22.00	109	15.00	0.13

* Unidades en milímetros.
Units in millimeters.

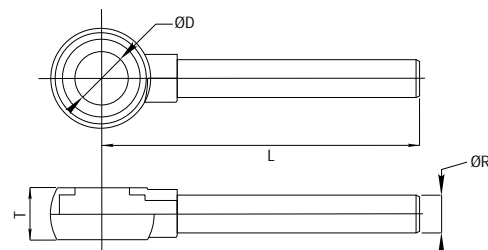

Esférico prensado largo

Long pressing banjo

RL

Referencia Reference	ØD	ØB	T	L	ØR	Peso Weight Kgs.
RL02015	1/4"	22	14.50	205	12.00	0.11
RL04016	3/8"	22	17.00	199	12.00	0.11
RL06016	1/2"	27	22.00	202	15.00	0.18

* Unidades en milímetros.
Units in millimeters.

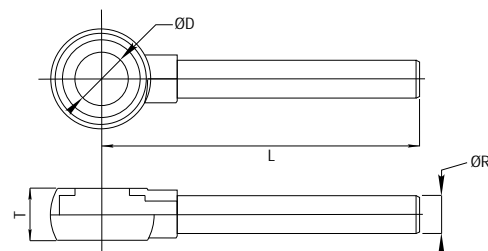

Esférico prensado extralargo

Extra-long pressing banjo

RE

Referencia Reference	ØD	ØB	T	L	ØR	Peso Weight Kgs.
RE02015	1/4"	22	14.50	305	12.00	0.15
RE02020	1/4"	22	14.50	405	12.00	0.19
RE04016	1/4"	22	14.50	505	12.00	0.23
RE04020	3/8"	22	17.00	300	12.00	0.15
RE06016	3/8"	27	17.00	400	12.00	0.18
RE06020	3/8"	27	17.00	500	12.00	0.22

* Unidades en milímetros.
Units in millimeters.

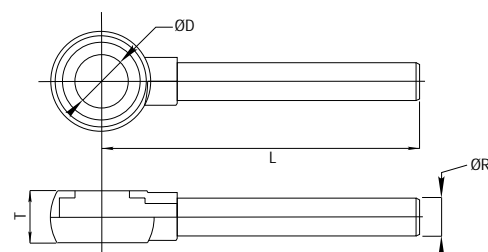

Tornillo simple

Simple screw

RK

Referencia Reference	ØD	Peso Weight Kgs.
RK02015	1/4"	0.04
RK04016	3/8"	0.05
RK06016	1/2"	0.09

* Unidades en milímetros.
Units in millimeters.

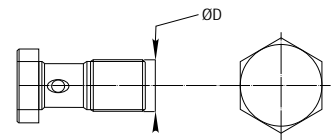

Acero C15 / Steel C15.
Tornillo simple / Single screw.

Arandela metalbuna

Metalbuna washer

RW

Referencia Reference	ØD	Peso Weight Kgs.
RW02015	1/4"	0.08
RW04016	3/8"	0.08
RW06016	1/2"	0.13

* Unidades en milímetros.
Units in millimeters.

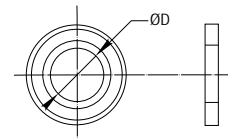

Arandela metalbuna / Metalbuna washer.
Otras medidas bajo pedido / Other measures on request.

Silenciador

Silencer plug

RD

Referencia Reference	ØD	Peso Weight Kgs.
RD02015	1/4"	0.11
RD04016	3/8"	0.11
RD06016	1/2"	0.18

* Unidades en milímetros.
Units in millimeters.

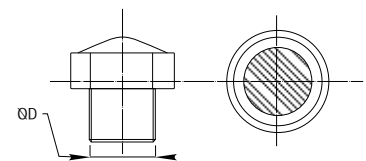

Silenciador de bronce / Bronze silencer plug.
Otras medidas bajo pedido / Other measures on request.

Tuerca tipo DL

DL nut type

RZ

Referencia Reference	ØD	ØB	Peso Weight Kgs.
RZ02015	1/4"	10	0.15
RZ02020	3/8"	12	0.19
RZ04016	1/2"	22	0.23

* Unidades en milímetros.
Units in millimeters.

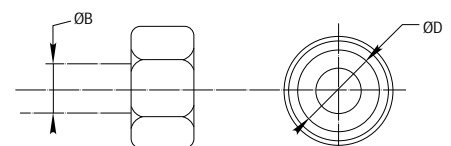

Tuerca tipo DL / DL nut type.
Otras medidas bajo pedido / Other measures on request.

Barra cromada CK45

Chrome bar Ck45

01

* Unidades en milímetros.
Units in millimeters.

Referencia Referencia	Ø	Peso Weight Kg/m
01-000016	16	1.58
01-000020	20	2.47
01-000025	25	3.85
01-000030	30	5.55
01-000035	35	7.55
01-000040	40	9.86
01-000045	45	12.50
01-000050	50	15.40
01-000055	55	17.27
01-000060	60	22.20
01-000065	65	26.00
01-000070	70	30.20
01-000075	75	34.70

Referencia Referencia	Ø	Peso Weight Kg/m
01-000080	80	39.50
01-000085	85	52.40
01-000090	90	49.91
01-000095	95	55.61
01-000100	100	61.62
01-000110	110	74.60
01-000115	115	81.54
01-000120	120	88.60
01-000125	125	96.30
01-000127	127	96.75
01-000130	130	104.00
01-000140	140	121.00
01-000150	150	139.00

Características técnicas:

*Tolerancia sobre diámetro ISO f7 / h7.
*Espesor de cromo 20 - 25 µ.
*Resistencia a la corrosión:
- 120 h según norma ASTM B117.
*Rugosidad (Ra) 0,2 µ.
*Grado de material Ck45.

Características mecánicas:

*Carga de rotura: 600-700 N/mm².
*Limite elástico: >340 N/mm².
*Alargamiento: 17%.
*Dureza Min. 207 HB.

Technical data :

*Tolerance on diameter ISO f7 / h7.
*Chrome thickness 20 - 25 µ.
*Corrosion resistance:
120 h according to norm ASTM B117.
*Rugosity (Ra) 0,2 µ.
*Material Ck45.

Mechanical characteristics :

*Breaking load: 600-700 N/mm².
*Elastic limit: >340 N/mm².
*Elongation: 17%.
*Hardness Min. 207 HB.

Barra cromada 42CrMo4

Chrome bar 42CrMo4

02

* Unidades en milímetros.
Units in millimeters.

Referencia Referencia	Ø	Peso Weight Kg/m
02-000016	16	1.58
02-000020	20	2.47
02-000025	25	3.85
02-000030	30	5.55
02-000035	35	7.55
02-000040	40	9.86
02-000045	45	12.50
02-000050	50	15.40
02-000055	55	17.27
02-000060	60	22.20
02-000065	65	26.00
02-000070	70	30.20
02-000075	75	34.70

Referencia Referencia	Ø	Peso Weight Kg/m
02-000080	80	39.50
02-000085	85	52.40
02-000090	90	49.91
02-000095	95	55.61
02-000100	100	61.62
02-000110	110	74.60
02-000115	115	81.54
02-000120	120	88.60
02-000125	125	96.30
02-000127	127	96.75
02-000130	130	104.00
02-000140	140	121.00
02-000150	150	139.00

Características técnicas:

*Tolerancia sobre diámetro ISO f7 / h7.
*Espesor de cromo 20 - 25 µ.
*Resistencia a la corrosión:
- 120 h según norma ASTM B117.
*Rugosidad (Ra) 0,2 µ.
*Grado de material 42CrMo4.

Características mecánicas:

*Carga de rotura: 900-1200 N/mm².
*Limite elástico: >650 N/mm².
*Alargamiento: 12%.
*Dureza Min. 241 HB.

Technical data :

*Tolerance on diameter ISO f7 / h7.
*Chrome thickness 20 - 25 µ.
*Corrosion resistance:
120 h according to norm ASTM B117.
*Rugosity (Ra) 0,2 µ.
*Material : 42CrMo4.

Mechanical characteristics :

*Breaking load : 900-1200 N/mm².
*Elastic limit: >650 N/mm².
*Elongation: 12%.
*Hardness Min. 241 HB.

Tubo de conducción

Feed pipe

10

* Unidades en milímetros.
Units in millimeters.

Referencia Referencia	Ø Exterior Outside	Espesor Thickness mm.	Peso Weight Kg/m
10-100015	10	1.5	0.32
10-100020	10	2.0	0.40
10-100025	10	2.5	0.47
10-120020	12	2.0	0.50
10-120025	12	2.5	0.59
10-120030	12	3.0	0.67
10-140020	14	2.0	0.60
10-140025	14	2.5	0.71
10-140030	14	3.0	0.82

Referencia Referencia	Ø Exterior Outside	Espesor Thickness mm.	Peso Weight Kg/m
10-150020	15	2.0	0.65
10-150025	15	2.5	0.78
10-150030	15	3.0	0.89
10-160020	16	2.0	0.70
10-160025	16	2.5	0.84
10-160030	16	3.0	0.97
10-180020	18	2.0	0.79
10-180025	18	2.5	0.96
10-180030	18	3.0	1.11

Características técnicas:

*Calidad de acero S152.
*Acabado BK.
*Según Norma :
DIN2393.

Características mecánicas:

*Carga de rotura : 600-700 N/mm².
*Limite elástico: >650 N/mm².
*Alargamiento: 4%.

Technical data :

*Steel S152.
*Finished BK.
*According to norm :
DIN2391.

Mechanical characteristics :

*Breaking load: 600-700 N/mm².
*Elastic load : >650 N/mm².
*Elongation: 4%.

Tubo lapeado Iso H8

Seamless cold-drawn tube H8

11

* Unidades en milímetros.
Units in millimeters.

Referencia Referencia	Ø Int.	Ø Ext.	Espesor mm.	Peso Weight Kg/m
11-040050	40	50	5.0	5.55
11-050060	50	60	5.0	6.78
11-050065	50	65	7.5	10.65
11-060070	60	70	5.0	8.05
11-060075	60	75	7.5	12.48
11-070080	70	80	5.0	9.25
11-070085	70	85	7.5	14.35
11-080090	80	90	5.0	10.50
11-080095	80	95	7.5	16.18
11-090100	90	100	5.0	11.71
11-090105	90	105	7.5	18.05
11-090110	90	110	10.0	24.70
11-100115	100	115	7.5	19.88

Referencia Referencia	Ø Int.	Ø Ext.	Espesor mm.	Peso Weight Kg/m
11-120140	120	140	10.0	32.10
11-130150	130	150	10.0	34.55
11-130160	130	160	15.0	53.65
11-140160	140	160	10.0	37.00
11-140170	140	170	15.0	57.35
11-150170	150	170	10.0	39.50
11-150180	150	180	15.0	61.05
11-160180	160	180	10.0	41.95
11-160190	160	190	15.0	64.75
11-180200	180	200	10.0	46.90
11-180210	180	210	15.0	74.15
11-200220	200	230	15.0	79.55
11-250300	250	300	25.0	169.55

Características técnicas:

*Material S152. Tol. h8.
*Acabado BK+S.
*Segun Norma :
DIN2391 / EN10305-1.

Características mecánicas:

*Carga de rotura : >570 N/mm².
*Limite elástico : >470 N/mm².
*Alargamiento: 14%.
*Rugosidad (Ra) 0.2 µ.

Technical data:

*Steel S152. Tol. h8.
*Finished BK+S.
*According to norm :
DIN2391 / EN10305-1.

Mechanical characteristics:

*Breaking load : >570 N/mm².
*Elastic load : >470 N/mm².
*Elongation: 14%.
*Rugosity (Ra) 0.2 µ.

Tubo lapeado Iso H9

Welded cold-drawn tube H9

12

* Unidades en milímetros.
Units in millimeters.

Referencia Referencia	Ø Int.	Ø Ext.	Espesor mm.	Peso Weight Kg/m
12-032040	32	40	4.0	3.55
12-035045	35	45	5.0	4.95
12-040050	40	50	5.0	5.55
12-045055	45	55	5.0	6.17
12-050060	50	60	5.0	6.78
12-055065	55	65	5.0	7.40
12-060070	60	70	5.0	8.01
12-060075	60	75	7.5	12.50
12-065075	65	75	5.0	8.63
12-070080	70	80	5.0	9.25
12-070085	70	85	7.5	14.30
12-080090	80	90	5.0	10.50
12-080095	80	95	7.5	16.20

Referencia Referencia	Ø Int.	Ø Ext.	Espesor mm.	Peso Weight Kg/m
12-032040	32	40	4.0	3.55
12-035045	35	45	5.0	4.95
12-040050	40	50	5.0	5.55
12-045055	45	55	5.0	6.17
12-050060	50	60	5.0	6.78
12-055065	55	65	5.0	7.40
12-060070	60	70	5.0	8.01
12-060075	60	75	7.5	12.50
12-065075	65	75	5.0	8.63
12-070080	70	80	5.0	9.25
12-070085	70	85	7.5	14.30
12-080090	80	90	5.0	10.50
12-080095	80	95	7.5	16.20

Características técnicas:

*Material S152. Tol. h9.
*Acabado BK.
*Segun Norma :
DIN2393.

Características mecánicas:

*Carga de rotura : >630 N/mm².
*Limite elástico : >540 N/mm².
*Alargamiento: 7%.
*Rugosidad (Ra) 0.4 - 0.6 µ.

Technical data:

*Steel S152. Tol. h9.
*Finished BK.
*According to norm :
DIN2393.

Mechanical characteristics:

*Breaking load : >630 N/mm².
*Elastic load : >540 N/mm².
*Elongation: 7%.
*Rugosity (Ra) 0.4 - 0.6 µ.

Tubo cromado Din2393 H9

Chromed cold-drawn tube H9

13

* Unidades en milímetros.
Units in millimeters.

Referencia Referencia	Ø Int.	Ø Ext.	Espesor mm.	Peso Weight Kg/m
13-032040	32	40	4.0	3.55
13-035045	35	45	5.0	4.95
13-040050	40	50	5.0	5.55
13-045055	45	55	5.0	6.17
13-050060	50	60	5.0	6.78
13-055065	55	65	5.0	7.40
13-060070	60	70	5.0	8.01
13-060075	60	75	7.5	12.50
13-065075	65	75	5.0	8.63

Referencia Referencia	Ø Int.	Ø Ext.	Espesor mm.	Peso Weight Kg/m
13-032040	32	40	4.0	3.55
13-035045	35	45	5.0	4.95
13-040050	40	50	5.0	5.55
13-045055	45	55	5.0	6.17
13-050060	50	60	5.0	6.78
13-055065	55	65	5.0	7.40
13-060070	60	70	5.0	8.01
13-060075	60	75	7.5	12.50
13-065075	65	75	5.0	8.63

Características técnicas:

*Material S152. Tol. h9.
*Acabado BK.
*Segun Norma :
DIN2393.

Características mecánicas:

*Carga de rotura : >630 N/mm².
*Limite elástico : >540 N/mm².
*Alargamiento: 7%.
*Cromado 25 - 30 micras.

Technical data:

*Steel S152. Tol. h9.
*Finished BK.
*According to norm :
DIN2393.

Mechanical characteristics:

*Breaking load : >630 N/mm².
*Elastic load : >540 N/mm².
*Elongation: 7%.
*Chromed 25 - 30 microns.

VÁLVULAS OLEOHIDRÁULICAS

Hydraulic valves

40

VALVULAS HIDRAULICAS

Antirretorno pilotada (extracorta)
Operated Check valve

VADP

Referencia Reference	D	B	T	L	Peso Weight Kg
VADP004EX	1/4"	64	36.00	134	0.65
VADP008EX	3/8"	64	36.00	134	0.63

Presión máxima / Max. pressure : 350 bar.

Aplicación :

Las válvulas VADP son usadas para bloquear cilindros de doble efecto.

Application :

VADP valves are used to lock double acting hydraulic cylinders.

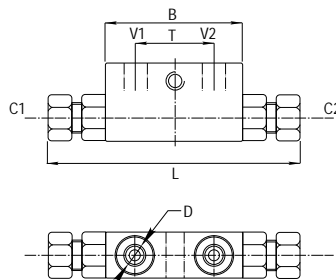

Esquema hidráulico
Hydraulic diagram

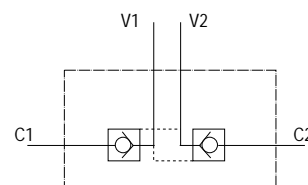

Cuerpo : Acero bicromatado
Body : Zinc plated steel.
Apertura muelle : 4.0 bar.
Open spring : 4.0 bar.

Racor para válvula VP
VP Valve adapter

RV..P/S

Referencia Reference	ØD	L	Peso Weight Kg
RVP004	1/4"	50	0.15
RVP006	3/8"	59	0.20
RVP008	1/2"	65	0.30

Referencia Reference	ØD	L	Peso Weight Kg
RVS004	1/4"	50	0.15
RVS006	3/8"	59	0.20
RVS008	1/2"	65	0.30

Cuerpo : Acero bicromatado
Body : Zinc plated steel.

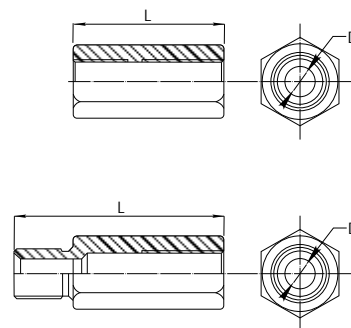

Válvula paracaídas
Burst valve

VP

Referencia Reference	ØD	L	Peso Weight Kg
VP004	1/4	23	0.15
VP006	3/8	23	0.20
VP008	1/2	34	0.30

Esquema hidráulico
Hydraulic diagram

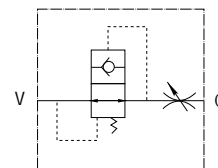
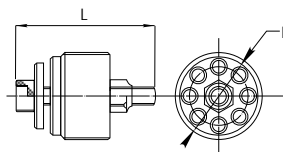

Cuerpo : Acero pavonado.
Body : Blued steel.

VÁLVULAS OLEOHIDRÁULICAS

Hydraulic valves

VALVULAS HIDRAULICAS

Válvula de volteo de arado
Plough overturning valve

VRA

Referencia Referencia	D	P	T	L	C1 / C2 Ø	Peso Weight Kg
VSEB03800	30	3/8"	3/8"	142	12.00	1.99
VSEB03802	30	3/8"	3/8"	142	12.00	1.99

Presión máxima / Max. pressure : 400 bar.

Aplicación :

Las válvulas VSEB son usadas para voltear cilindros de simple y doble efecto.

Application :

VSEB valves are used to turning plough in double and single acting cylinders.

Inversión a / Inversion to : 140 bar.

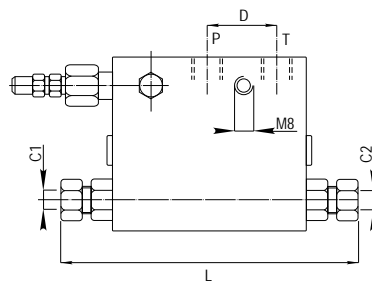

Cuerpo : Acero bicromatado
Body : Zinc plated steel.

Esquema hidráulico
Hydraulic diagram

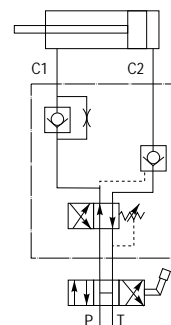

Reguladora de caudal 90°
90° Flow regulator valve

VRU

Referencia Referencia	ØD	S	M	L	Caudal máx. Max. flow Ll/min.	Presión máx. Max. pressure Bar	Peso Weight Kg
VRU04002	1/4"	25	M22x1.5	82	15.0	350	0.37
VRU04004	3/8"	25	M22x1.5	82	30.0	350	0.36
VRU04006	1/2"	30	M22x1.5	87	50.0	350	0.47
VRU04008	3/4"	40	M35x1.5	108	80.0	280	1.10
VRU04010	1"	40	M35x1.5	129	80.0	250	1.00

* Regulación: Unidireccional.
Regulation: One way.

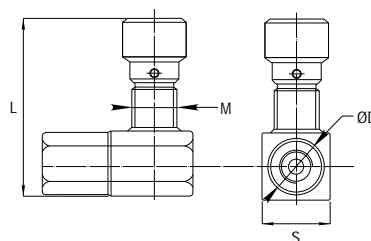

Esquema hidráulico
Hydraulic diagram

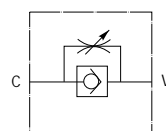

Cuerpo : Acero bicromatado
Body : Zinc plated steel.

Reguladora de caudal 90°
90° Flow regulator valve

VRB

Referencia Referencia	ØD	S	M	L	Caudal máx. Max. flow Ll/min.	Presión máx. Max. pressure Bar	Peso Weight Kg
VRB04002	1/4"	25	M22x1.5	82	15.0	350	0.42
VRB04004	3/8"	25	M22x1.5	82	30.0	350	0.42
VRB04006	1/2"	30	M22x1.5	87	50.0	350	0.59
VRB04008	3/4"	40	M35x1.5	108	80.0	280	1.36
VRB04010	1"	40	M35x1.5	129	80.0	250	1.39

* Regulación: Bidireccional.
Regulation: Two ways.

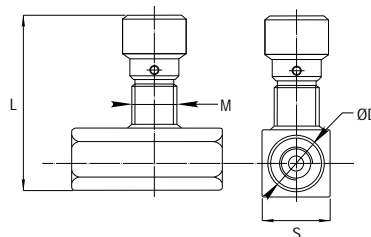

Esquema hidráulico
Hydraulic diagram

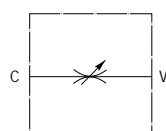

Cuerpo : Acero bicromatado
Body : Zinc plated steel.

*Apertura: 0.5 bar.
Cracking pressure: 0.5 bar.

KITS DE JUNTAS Oil seals kits

KIT DE JUNTAS

Kit de juntas Serie 100 100 Series seals kit

KJSE

Referencia Reference	Ø Vástago Ø Rod	Ø Tubo Ø Tube
KJSE032040025	25	32/40
KJSE040050030	30	40/50
KJSE045055035	35	45/55
KJSE050060040	40	50/60
KJSE050060045	45	50/60
KJSE055065050	50	55/65
KJSE060070055	55	60/70
KJSE065075060	60	65/75
KJSE065075060	60	65/75
KJSE080090070	70	80/90
KJSE100115090	90	100/115

Kit de juntas / Oil seal kit

- A Rascador metálico / Metal wiper.
- B Collarín poliuretano / Polyurethane rod seal.
- C Guías resina acetil / Acetal resin guides.
- D Junta tórica 90 shores / O-ring 90 shores.
- E Tuerca KM / KM nut.

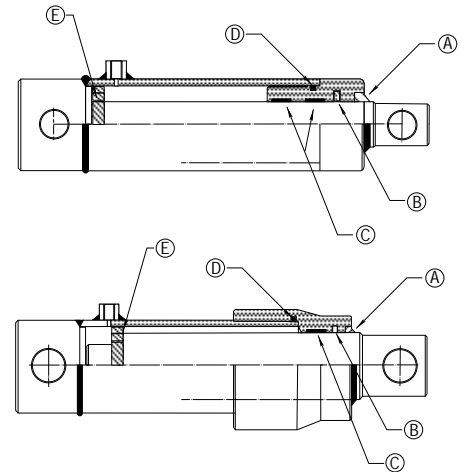

* Otras medidas bajo consulta.
Other measures on request.

Kit de juntas Serie 200 200 Series seals kit

KJDE

Referencia Reference	Ø Vástago Ø Rod	Ø Tubo Ø Tube
KJDE032040020	20	32/40
KJDE040050020	20	40/50
KJDE040050025	25	40/50
KJDE050060025	25	50/60
KJDE050060030	30	50/60
KJDE050060035	35	50/60
KJDE060070030	30	60/70
KJDE060070035	35	60/70
KJDE060070040	40	60/70
KJDE070080035	35	70/80
KJDE070080040	40	70/80
KJDE070080045	45	70/80
KJDE070080050	50	70/80
KJDE080090035	35	80/90
KJDE080090040	40	80/90

Referencia Reference	Ø Vástago Ø Rod	Ø Tubo Ø Tube
KJDE080090045	45	80/90
KJDE080090050	50	80/90
KJDE090100040	40	90/100
KJDE090100045	45	90/100
KJDE090100050	50	90/100
KJDE090100060	60	90/100
KJDE100115050	50	100/115
KJDE100115060	60	100/115
KJDE100115070	70	100/115
KJDE120140060	60	120/140
KJDE120140070	70	120/140
KJDE120140080	80	120/140
KJDE130150070	70	130/150
KJDE130150080	80	130/150
KJDE130150090	90	130/150

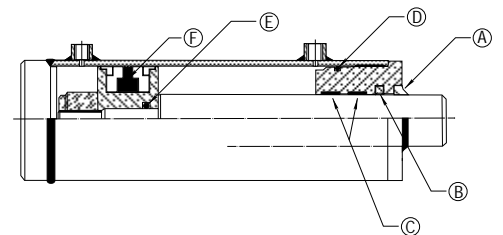

Kit de juntas / Oil seal kit

- A Rascador metálico / Metal wiper.
- B Collarín poliuretano / Polyurethane rod seal.
- C Guías resina acetil / Acetal resin guides.
- D Junta tórica 90 shores / O-ring 90 shores.
- E Junta tórica 90 shores / O-ring 90 shores.
- F Junta Pistón DBM / DBM piston seal.

* Otras medidas bajo consulta.
Other measures on request.