

Tarifa General  
Tarif Général  
General Price List  
Listino Prezzi

Fluytex



AISI 316L

### Racores Inoxidable

Raccords en Acier Inox  
Stainless Steel Fittings  
Raccordi en Acciaio Inossidabile



1

Conexiones para flexibles  
Embouts à sertir pour flexibles  
Crimp fittings for hoses  
Raccordi a pressare per tubi flessibili

2

Racores para tubo rígido DIN 2353  
Raccord tube rigide DIN 2353  
Pipe fittings DIN 2353  
Raccordi ad anello DIN 2353

3

Racores JIC 37° / Bidas SAE  
Raccords JIC 37° / Brides SAE  
Flare fittings JIC 37° / SAE Flanges  
Raccordi JIC 37° / Flange SAE

4

Adaptadores  
Adaptateurs  
Adaptors  
Adattatori

5

Racores soldables  
Raccords à souder  
Welding fittings  
Raccordi a saldare

6

Racores industriales  
Raccords industriels  
Industrial fittings  
Raccordi industriali

7

Enchufes rápidos, Llaves de paso y Componentes hidráulicos  
Coupleurs rapides, Robinets et Composants Hydrauliques  
Couplings, Ball valves and Hydraulic Components  
Innesti rapidi, Rubinetti a sfera e Componenti Idraulici



## Conexiones para flexibles

**Embouts à sertir pour flexibles**

**Crimp fittings for hoses**

**Raccordi a pressare per tubi flessibili**

▶	Conexiones Standard	7
	Embouts série standard   Standard series   Serie Standard	
▶	Conexiones Interlock	9
	Embouts Interlock   Interlock series   Serie Interlock	
▶	Conexiones Compactas Serie 43 R1AT/R2AT/1SN/2SN/R16/R17/2SC	10
	Embouts pré-sertis R1AT/R2AT/1SN/2SN/R16/R17/2SC Série 43   One piece fittings 43 Series R1AT/R2AT/1SN/2SN/R16/R17/2SC   Raccordi compatti R1AT/R2AT/1SN/2SN/R16/R17/2SC Serie 43	
▶	Conexiones Compactas R7/R8 y Elastómero malla metálica	11
	Embouts pré-sertis R7/R8 et Tresse métallique   One piece fittings R7/R8 & Braid of steel wire   Raccordi compatti serie R7/R8 e elastomero treccia metallica	
▶	Conexiones Compactas PTFE Liso	12
	Embouts pré-sertis pour PTFE lisse   One piece fittings for Smooth PTFE   Raccordi compatti serie PTFE liscio	
▶	Conexiones Compactas PTFE Corrugado	13
	Embouts pré-sertis pour PTFE convoluté   One piece fittings for convoluted PTFE   Raccordi compatti serie PTFE involuto	
▶	Conexiones Compactas Serie BW R12/4SP/4SH	14
	Embouts pré-sertis R12/4SP/4SH Série BW   One piece fittings BW Series R12/4SP/4SH   Raccordi Compatti R12/4SP/4SH Serie BW	
▶	Casquillos para Conexiones Compactas	15
	Jupes pour embouts pré-sertis   Ferrules for one piece fittings   Boccole per raccordi compatti	
▶	Conexiones Reusables	16
	Embouts série récupérable   Reusable series   Serie Recuperabile	
▶	Conexiones Push-On	17
	Embouts Push-On   Push-On Fittings   Raccordi Serie Push-On	
▶	Conexiones Alta Presión (700 bar)	18
	Embouts haute pression 700 bar   High pressure 700 bar fittings   Raccordi Altissima pressione (700 bar)	
▶	Conexiones Micro-hose	19
	Embouts Minimess   Micro-hose fittings   Raccordi Micro-tubo	

# Serie Standard

Standard serie | Serie Standard | Standard serie

Crimp fittings for hoses

Pipe fittings DIN 2353

Flare fittings JIC  
SAE flanges

Adaptors

Welding fittings

Industrial fittings

Several items

► **Una única conexión para una amplia gama de mangueras** | Un seul raccord pour une grande gamme de tuyaux | One only fitting for a big hose range | Un solo raccordo per una vasta gamma di tubi

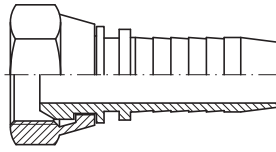

EN 857 1 SC	SUPERSERVICE 155° 1SC	R8	SAE 100 R7	Metallic Braid Elastomer	SAE 100 R6	Smooth PTFE 1 Braid	Convolute PTFE
ZSC2112...	ZSC2112...	81014...	81014...	81014...	81014...	81040...	81041...

EN 853 1ST SAE 100 R1A	EN 853 1 SN SAE 100 R1AT	EN 853 2SN SAE 100 R2AT	EN 857 2SC SAE 100 R16	SUPERSERVICE 155° 2SC	EN 853 2ST SAE 100 R2A	EN 856 4SP	EN 856 R12
82003...	ZPF22120... ZSC2112	ZPF22120...	ZPF22120...	ZPF22120...	ZPF12240...	ZPF12240...	ZPF12240...

# Serie Interlock

Série interlock | Interlock serie | Serie Interlock

► **Una única conexión para toda la gama de mangueras de alta presión** | Un seul raccord pour tous les tubes de très haute pression | One only fitting for all very high pressure hoses | Un solo raccordo per tutti i tubi ad altissima pressione

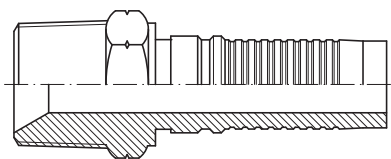

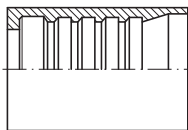
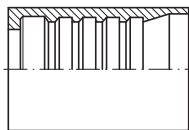
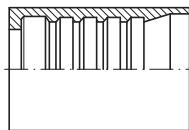
	<b>4 SH</b>	<b>R 13</b>	<b>R 15</b>	
				
	ZA61010...	ZA61010... Z61010...	ZA61010... Z61010...	

## Serie Compacta

Série Pré-sertis | One Piece Series | Serie Compatti

- **Conexiones Compactas Serie 43 R1AT/R2AT/1SN/2SN/R16/R17/2SC** | Embouts pré-sertis R1AT/R2AT/1SN/2SN/R16/R17/2SC Série 43 | One piece fittings 43 Series R1AT/R2AT/1SN/2SN/R16/R17/2SC | Raccordi compatti R1AT/R2AT/1SN/2SN/R16/R17/2SC Serie 43

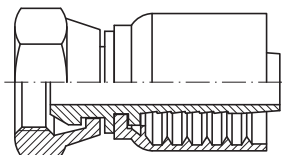

EN 853 1SN SAE 100 R1AT	EN 853 2 SN SAE 100 R2AT	EN 857 2SC SAE 100 R16	R17	SUPERSERVICE 155° 2SC
----------------------------------	-----------------------------------	---------------------------------	-----	-----------------------------

- **Conexiones Compactas R7/R8 y Elastómero malla metálica** | Embouts pré-sertis R7/R8 et Tresse métallique | piece fittings R7/R8 & Braid of steel wire | Raccordi compatti serie R7/R8 e elastomero treccia metallica

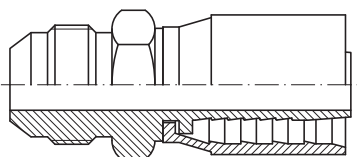

SAE 100 R7	SAE 100 R8	Metallic Braid Elastomer
---------------	---------------	--------------------------------

- **Conexiones Compactas PTFE Liso** | Embouts pré-sertis pour PTFE lisse | One piece fittings for Smooth PTFE | Raccordi compatti serie PTFE liscio

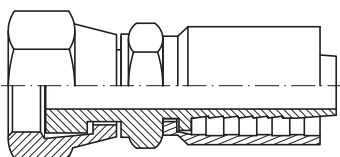

Smooth  
PTFE  
1 Braid

- **Conexiones Compactas PTFE Corrugado** | Embouts pré-sertis pour PTFE convolute | One piece fittings for convoluted PTFE | Raccordi compatti serie PTFE involuto

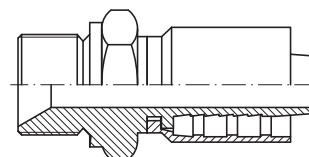

Convoluted  
PTFE

- **Conexiones Compactas Serie BW R12/4SP/4SH** | Embouts pré-sertis R12/4SP/4SH Série BW | One piece fittings BW Series R12/4SP/4SH | Raccordi Compatti R12/4SP/4SH Serie BW

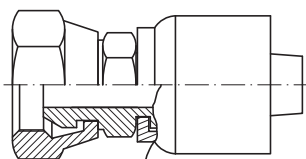

EN 856 R12	EN 856 4SP	4 SH
---------------	---------------	------



# Conexiones Standard

Embouts série standard | Standard series | Serie Standard

## ▶ Casquillos para prensar | Jupes à sertir | Crimp ferrules | Boccole a pressare

21

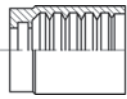

ZPF2212

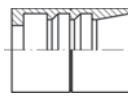

82003

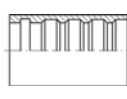

81040

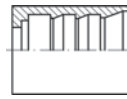

ZPF1224

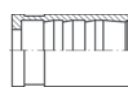

81014

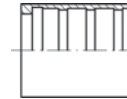

81041

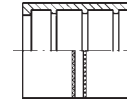

Z21200

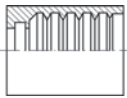

ZSC2112

## ▶ Conexiones BSP | Embouts BSP | BSP Fittings | Raccordi BSP

23



84100



84108

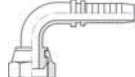

84107

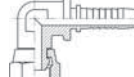

84127

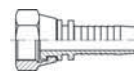

84200



84207



84208



84110

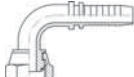

84117



84118

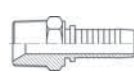

84114

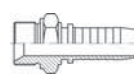

84112

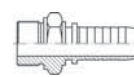

84212

## ▶ Conexiones NPT-NPSM | Embouts NPT-NPSM | NPT-NPSM Fittings | Raccordi NPT-NPSM

26



84261

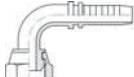

84262



84263

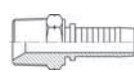

84161

## ▶ Conexiones JIC 37° | Embouts JIC 37° | JIC 37° Fittings | Raccordi JIC 37°

27



84142



84138



84139



84140



84141



84137

## ▶ Conexiones Métricas DIN 2353 | Embouts Métriques | Metric fittings | Raccordi Metrici

28

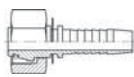

84804

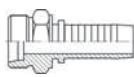

84203

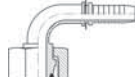

84305



84306

## ▶ Conexiones doble hexagonal | Embouts double hexagonal | Double hexagonal fittings | Raccordi Doppio Esagono

30



84400



84361



84242

Crimp fittings for hoses

Pipe fittings DIN 2353

Flare fittings JIC  
SAE flanges

Adaptors

Welding fittings

Industrial fittings

Several items

▶ **Terminales hidrolavadoras** | Embouts pour hydronettoyages | Hydrowashing machine couplings | Raccordi per idropulitrici

30



83050



KZTHAP

▶ **Espigas lisas** | Embouts lisses | Standpipes | Estremità tubolari

31



84158



84159

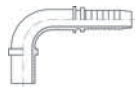

84258

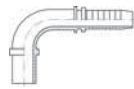

84259



84358



84359

▶ **Conexiones Varias** | Plusieurs Embouts | Several Fittings | Diversi Raccordi

32



84300



84000

▶ **Orientables** | Embouts Banjo | Banjos | Raccordi ad occhio

33



84111

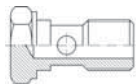

Z1090

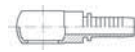

84116

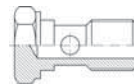

Z1092

▶ **Bridas SAE** | Brides SAE | SAE Flanges | Flange SAE

34



84182



84183



84184



84282



84283



84284

▶ **Bridas para flexibles** | Brides SAE pour flexibles | SAE Flanges for hoses | Flange per tubi flessibili

35

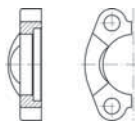

ZBBP

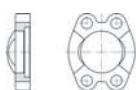

ZBBE

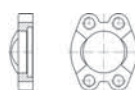

ZBCE

▶ **Conexiones ORFS** | Embouts ORFS | ORFS Fittings | ORFS

36

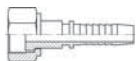

84900



84901



84912



84907



84908



84712

# Conexiones Interlock

Embouts Interlock | Interlock series | Serie Interlock

► **Casquillos** | Jupes à sertir Interlock | Interlock Crimp ferrules | Boccole a pressare 37

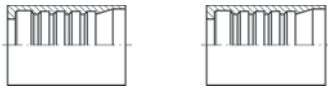

ZA61010      Z61010

► **Conexiones BSP** | Embouts à sertir Interlock BSP | Interlock BSP fittings | Raccordi BSP 37



Z64100      Z64107      Z64108      Z64112      Z64161

► **Conexiones JIC 37°** | Embouts à sertir Interlock JIC | Interlock JIC 37° fittings | Raccordi JIC 37° 38



Z64142      Z64138      Z64139      Z64140

► **Conexiones Métricas DIN 2353** | Embouts Métrique Interlock | Interlock Metric fittings | Raccordi Metrici 38



Z64204      Z64205      Z64206      Z64203

► **Conexiones ORFS** | Embouts à sertir Interlock ORFS | Interlock ORFS fittings | Raccordi ORFS 39



Z64901      Z64912      Z64907      Z64908

► **Conexiones doble hexagonal** | Embouts à sertir Interlock double hexagonal | Double hexagonal Interlock fittings | Raccordi Doppio Esagono 39



Z64400      Z64242

► **Bridas SAE** | Brides SAE Interlock | Interlock SAE Flanges | Flange SAE 40



Z64182      Z64183      Z64184      Z64282      Z64283      Z64284

## Conexiones Compactas Serie 43 R1AT/R2AT/1SN/2SN/R16/R17/2SC

Embouts pré-sertis R1AT/R2AT/1SN/2SN/R16/R17/2SC Série 43 | One piece fittings 43 Series R1AT/R2AT/1SN/2SN/R16/R17/2SC | Raccordi compatti R1AT/R2AT/1SN/2SN/R16/R17/2SC Serie 43

### ▶ Conexiones compactas JIC 37° | Embouts pré-sertis JIC 37° | One piece JIC 37° fittings | Raccordi compatti JIC 37°

42

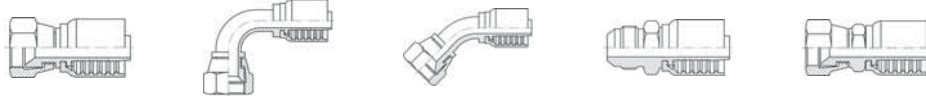

88142

88138

88139

88140

88242

### ▶ Conexiones compactas ORFS | Embouts pré-sertis ORFS | One piece ORFS fittings | Raccordi compatti ORFS

43



88900

88907

88908

88912

### ▶ Conexiones compactas NPT-NPSM | Embouts pré-sertis NPT-NPSM | One piece NPT-NPSM fittings | Raccordi compatti NPT-NPSM

44

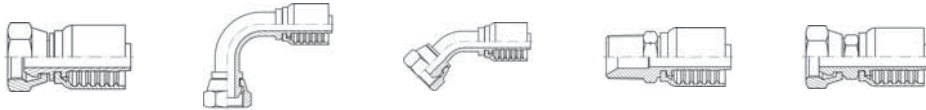

88261

88262

88263

88161

88361

### ▶ Conexiones compactas Bridas SAE | Embouts pré-sertis Brides SAE | One piece SAE Flanges fittings | Raccordi compatti Flange SAE

45



88182

88183

88184

88282

88283

88284

### ▶ Conexiones compactas Métricas | Embouts pré-sertis Metric | One piece Metric fittings | Raccordi compatti Metrici

46



88804

88305

88306

88203

### ▶ Conexiones compactas BSP | Embouts pré-sertis BSP | One piece BSP fittings | Raccordi compatti BSP

47

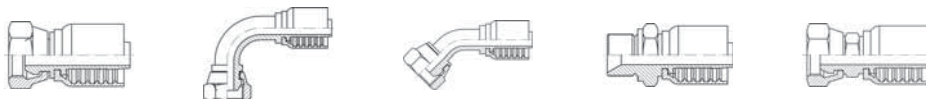

88100

88107

88108

88112

88400

# Conexiones Compactas R7/R8 y Elastómero malla metálica

Embouts pré-sertis R7/R8 et Tresse métallique | One piece fittings R7/R8 & Braid of steel wire | Raccordi compatti serie R7/R8 e elastomero treccia metallica

## ▶ **Conexiones compactas R7/R8 JIC 37°** | Embouts pré-sertis R7/R8 JIC 37° | 37° JIC One piece fittings R7/R8 | Raccordi compatti serie R7/R8 JIC sede 37° 48



87142      87138      87139      87140      87242

## ▶ **Conexiones compactas R7/R8 ORFS** | Embouts pré-sertis R7/R8 ORFS | ORFS One piece fittings R7/R8 | Raccordi compatti serie R7/R8 ORFS 49

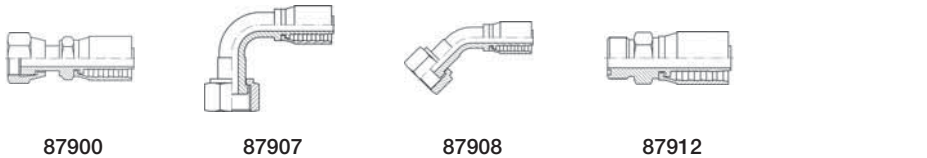

87900      87907      87908      87912

## ▶ **Conexiones compactas R7/R8 NPT-NPSM** | Embouts pré-sertis R7/R8 NPT-NPSM | NPT-NPSM One piece fittings R7/R8 | Raccordi compatti serie R7/R8 NPT-NPSM 50



87261      87262      87263      87161      87361

## ▶ **Conexiones compactas R7/R8 Métricas** | Embouts pré-sertis R7/R8 Métriques | Metric One piece fittings R7/R8 | Raccordi compatti serie R7/R8 Metrici 51

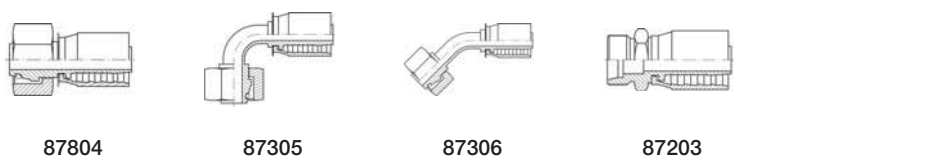

87804      87305      87306      87203

## ▶ **Conexiones compactas R7/R8 BSP** | Embouts pré-sertis R7/R8 BSP | BSP One piece fittings R7/R8 | Raccordi compatti serie R7/R8 BSP 52



87100      87107      87108      87112      87400

## Conexiones Compactas PTFE Liso

Embouts pré-sertis pour PTFE lisse | One piece fittings for Smooth PTFE | Raccordi compatti serie PTFE liscio

### ▶ Conexiones compactas PTFE liso JIC 37° | Embouts pré-sertis PTFE lisse JIC 37° | 37° JIC One piece fittings smooth PTFE | Raccordi compatti serie PTFE liscio JIC 37°

53

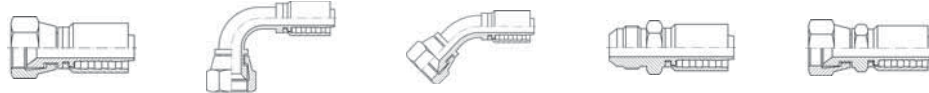

86142

86138

86139

86140

86242

### ▶ Conexiones compactas PTFE liso ORFS | Embouts pré-sertis PTFE lisse ORFS | ORFS One piece fittings smooth PTFE | Raccordi compatti serie PTFE liscio ORFS

54

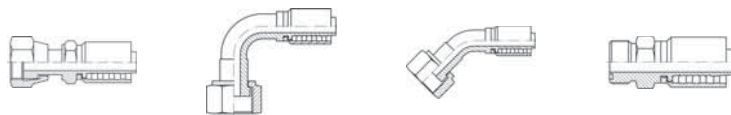

86900

86907

86908

86912

### ▶ Conexiones compactas PTFE liso NPT-NPSM | Embouts pré-sertis PTFE lisse NPT-NPSM | NPT-NPSM One piece fittings smooth PTFE | Raccordi compatti serie PTFE liscio NPT-NPSM

55



86261

86262

86263

86161

86361

### ▶ Conexiones compactas PTFE liso Métricas | Embouts pré-sertis PTFE lisse Métriques | Metric One piece fittings smooth PTFE | Raccordi compatti serie PTFE liscio Metrici

56



86804

86305

86306

86203

### ▶ Conexiones compactas PTFE liso BSP | Embouts pré-sertis PTFE lisse BSP | BSP One piece fittings smooth PTFE | Raccordi compatti serie PTFE liscio BSP

57

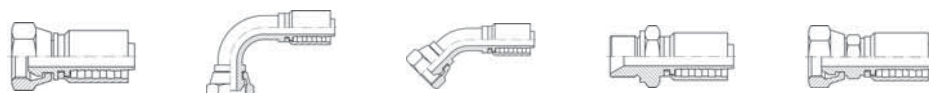

86100

86107

86108

86112

86400

# Conexiones Compactas PTFE Corrugado

Embouts pré-sertis pour PTFE convoluto | One piece fittings for convoluted PTFE | Raccordi compatti serie PTFE involuto

▶ **Conexiones compactas PTFE Corrugado JIC 37°** | Embouts pré-sertis pour PTFE convoluto JIC 37° | One piece fittings for convoluted PTFE JIC 37° | Raccordi compatti serie PTFE involuto JIC 37° 58



▶ **Conexiones compactas PTFE Corrugado ORFS** | Embouts pré-sertis pour PTFE convoluto ORFS | One piece fittings for convoluted PTFE ORFS | Raccordi compatti serie PTFE involuto ORFS 59

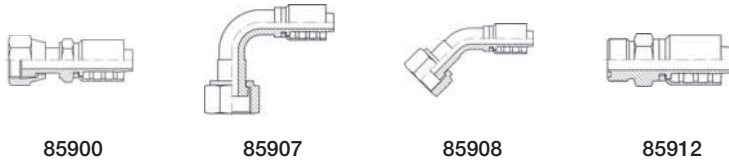

▶ **Conexiones compactas PTFE Corrugado NPT-NPSM** | Embouts pré-sertis pour PTFE convoluto NPT-NPSM | One piece fittings for convoluted PTFE NPT | Raccordi compatti serie PTFE involuto NPT 60



▶ **Conexiones compactas PTFE Corrugado Métricas** | Embouts pré-sertis pour PTFE convoluto Métriques | One piece fittings for convoluted PTFE Metric | Raccordi compatti serie PTFE involuto METRICI 61

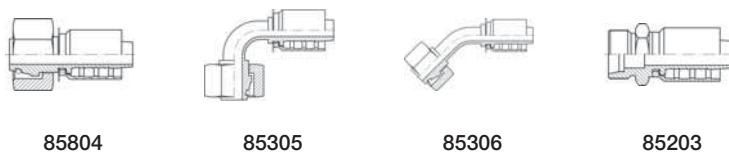

▶ **Conexiones compactas PTFE Corrugado BSP** | Embouts pré-sertis pour PTFE convoluto BSP | One piece fittings for convoluted PTFE BSP | Raccordi compatti serie PTFE involuto BSP 62

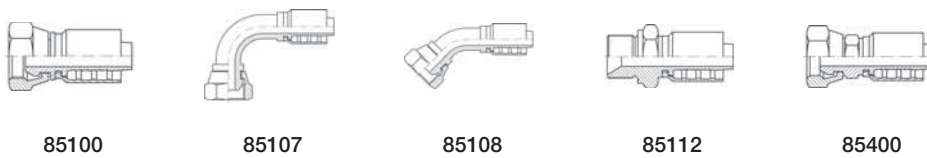

## Conexiones Compactas Serie BW R12/4SP/4SH

Embouts pré-sertis R12/4SP/4SH Série BW | One piece fittings BW Series R12/4SP/4SH | Raccordi Compatti R12/4SP/4SH Serie BW

### ▶ Conexiones compactas JIC 37° | Embouts pré-sertis JIC | One piece JIC 37° fittings | Raccordi compatti JIC 37°

63

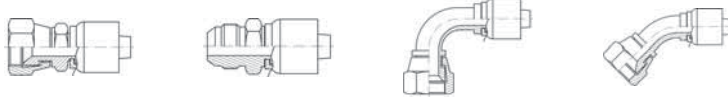

Z68242

Z68140

Z68138

Z68139

### ▶ Conexiones compactas ORFS | Embouts pré-sertis ORFS | One piece ORFS fittings | Raccordi compatti ORFS

63

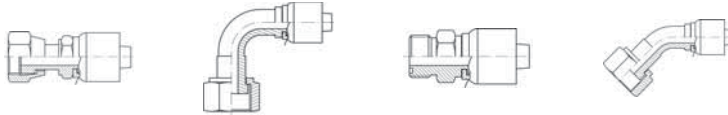

Z68901

Z68907

Z68912

Z68908

### ▶ Conexiones compactas NPT/NPSM | Embouts pré-sertis NPT/NPSM | One piece NPT/NPSM fittings | Raccordi compatti NPT/NPSM

64



Z68361

Z68161

### ▶ Conexiones compactas Bridas SAE | Brides SAE pré-séries | One piece SAE Flanges | Flange SAE compatta

64

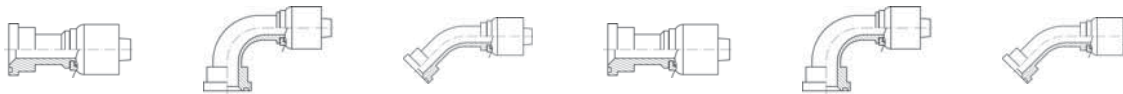

Z68182

Z68183

Z68184

Z68282

Z68283

Z68284

### ▶ Conexiones compactas Métricas DIN 2353 | Embouts pré-sertis Métriques | One piece Metric fittings | Raccordi compatti Metrici

65

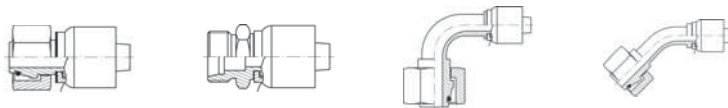

Z68204

Z68203

Z68205

Z68206

### ▶ Conexiones compactas BSP | Embouts pré-sertis BSP | One piece BSP fittings | Raccordi compatti BSP

65



Z68400

Z68107

Z68108

Z68112



# Casquillos para Conexiones Compactas

Jupes pour embouts pré-sertis | Ferrules for one piece fittings | Boccole per raccordi compatti

Casquillos para Conexiones Compactas | Jupes pour embouts pré-sertis | Ferrules for one piece fittings | Boccole per raccordi compatti

66

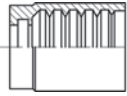

ZPFC2212

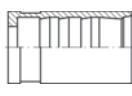

88012

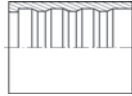

88040

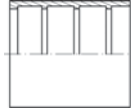

88041

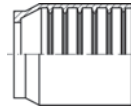

ZAC6801

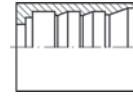

ZPFC1224

Crimp fittings for hoses

Pipe fittings DIN 2353

Flare fittings JIC  
SAE flanges

Adaptors

Welding fittings

Industrial fittings

Several items

## Conexiones Reusables

Embouts série récupérable | Reusable series | Serie Recuperabile

### ▶ Casquillos | Jupes à sertir | Crimp ferrules | Boccole a pressare

68

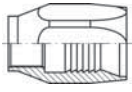

Z1G...R1

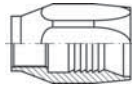

Z1G...R1T

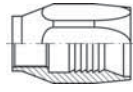

Z1G...R2

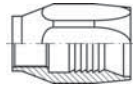

Z1G...R2T

### ▶ Conexiones | Embouts | Fittings | Raccordi

68



Z3G



Z90G



Z2G



ZE

# Conexiones Push-On

Embouts Push-On | Push-On Fittings | Raccordi Serie Push-On

► **Conexiones Push-On BSP** | Embouts Push-on BSP | Push-on BSP fittings | Raccordi Serie Push-on BSP 70



89100 89112

► **Conexiones Push-On JIC 37°** | Embouts Push-on JIC 37° | Push-on 37° JIC fittings | Raccordi Serie Push-on JIC 37° 70



89142 89140

► **Conexiones Push-On NPT** | Embouts Push-on NPT | Push-on NPT fittings | Raccordi Serie Push-on NPT 70

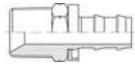

89161

► **Conexiones Push-On Métricas DIN 2383** | Embouts Push-on Métriques | Push-on Metric fittings | Raccordi Serie Push-on Metrici 71



89804 89203

## Conexiones Alta Presión (700 bar)

Embouts haute pression 700 bar | High pressure 700 bar fittings | Raccordi Altissima pressione (700 bar)

- ▶ **Casquillos para prensar** | Jupes à sertir | Ferrules | Boccole

72

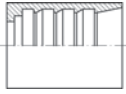

Z71012

- ▶ **Conexiones BSP** | Embouts BSP | BSP Fittings | Raccordi BSP

72



Z74100



Z74112

- ▶ **Conexiones NPSM / NPT** | Embouts NPSM / NPT | NPSM / NPT Fittings | Raccordi NPSM / NPT

72



Z74261



Z74161

- ▶ **Conexiones JIC 37°** | Embouts JIC 37° | JIC 37° Fittings | Raccordi JIC 37°

72



Z74142

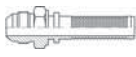

Z74140

- ▶ **Conexiones Métricas** | Embouts | Metric Fittings | Raccordi Metrici

73

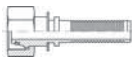

Z74804

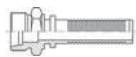

Z74203

# Conexiones Micro-hose

Embouts Minimess | Micro-hose fittings | Raccordi Micro-tubo

## Conexiones Micro-hose | Embouts Minimess | Micro-hose fittings | Raccordi Micro-tubo

74

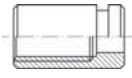

Z55501

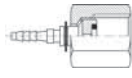

Z55505

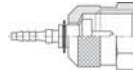

Z55506

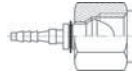

Z55504



Z55507



Z55503



Z MPR

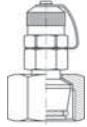

Z MPR TLM

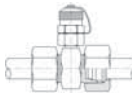

Z MPR DL/S



## Conexiones Standard

Embouts série standard  
Standard series  
Serie Standard

### Casquillos R1AT/R2AT/ 1SN/2SN/ R16/2SC

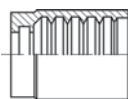

Jupes R1AT/R2AT/1SN/2SN/R16/2SC

Ferrules R1AT/R2AT/1SN/2SN/R16/2SC

Boccole pressare per R1AT/R2AT/1SN/2SN/R16/2SC

DN	SERIE	REFERENCIA PART N°	€
3/16"	R1AT	810200300	
3/16"	R2AT	810300300	
1/4"	--	ZPF221200400	
5/16"	--	ZPF221200500	
3/8"	--	ZPF221200600	
1/2"	--	ZPF221200800	
5/8"	--	ZPF221201000	
3/4"	--	ZPF221201200	
1"	--	ZPF221201600	
1"1/4	--	ZPF221202000	
1"1/2	--	ZPF221202400	
2"	--	ZPF221203200	

### Casquillos R2A-2ST/4SP DIN 20023

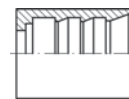

Jupes R2A-2ST/4SP DIN 20023

Ferrules R2A-2ST/DIN 20023 4SP R9R

Boccole pressare per R2A-2ST/DIN 20023

DN	SERIE	REFERENCIA PART N°	€
3/16"	R2A	820060300	
1/4"	--	ZPF122400400	
5/16"	--	ZPF122400500	
3/8"	--	ZPF122400600	
1/2"	--	ZPF122400800	
5/8"	--	ZPF122401000	
3/4"	--	ZPF122401200	
1"	--	ZPF122401600	
1"1/4	--	ZPF122402000	
1"1/2	--	ZPF122402400	
2"	--	ZPF122403200	

### Casquillos R1A-1ST



Jupes R1A-1ST

Ferrules R1A-1ST

Boccole pressare per R1A-1ST

DN	REFERENCIA PART N°	€
3/16"	820030300	
1/4"	820030400	
5/16"	820030500	
3/8"	820030600	
1/2"	820030800	
5/8"	820031000	
3/4"	820031200	
1"	820031600	
1"1/4	820032000	
1"1/2	820032400	
2"	820033200	

### Casquillos R7/R8 y elastómero malla metálica

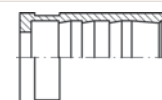

Jupes R7/R8 et tresse métallique

Ferrules R7/R8 and braid with steel braid

Boccole pressare per R7/R8 e elastomero treccia metallica

DN	REFERENCIA PART N°	€
1/8"	810140200	
3/16"	810140300	
1/4"	810140400	
5/16"	810140500	
3/8"	810140600	
1/2"	810140800	
5/8"	810141000	
3/4"	810141200	
1"	810141600	

\*No válidos para R8 / Pas valable pour R8 / Not suitable for R8 / Non valido per R8

### Casquillos PTFE Liso

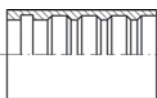

Jupes PTFE lisse

Ferrules for smooth PTFE

Boccole pressare per PTFE liscio

DN	REFERENCIA PART N°	€
3/16"	810400300	
1/4"	810400400	
5/16"	810400500	
3/8"	810400600	
1/2"	810400800	
5/8"	810401000	
3/4"	810401200	
7/8"	810401400	
1"	810401600	
1"1/8	810401800	

### Casquillos PTFE Corrugado

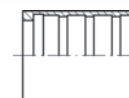

Jupes PTFE convoluté

Ferrules for convoluted PTFE

Boccole pressare per PTFE corrugato

DN	REFERENCIA PART N°	€
1/4"	810410400	
5/16"	810410500	
3/8"	810410600	
1/2"	810410800	
5/8"	810411000	
3/4"	810411201	
1"	810411600	
1"1/4	810412000	
1"1/2	810412400	
2"	810413200	
2"1/2	810414000	

## Conexiones Standard

Embouts série standard  
Standard series  
Serie Standard

### Casquillos para mangueras Ecology y Limpieza de Alcantarillas

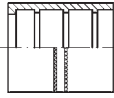

Jupes pour tuyau Ecology et tuyau Hydrocurage  
Ferrules for Ecology hose and Sewer Jetting hose  
Boccole pressare per tubi Ecology e pulizia fossa biologica

DN	REFERENCIA PART N°	€
3/4"	Z212001200	
1"	Z212001600	
1"1/4	Z212002000	

### Casquillos 1SC/1SN/ R6/2TE/3TE



Jupes 1SC/1SN/R6/2TE/3TE  
Ferrules 1SC/1SN/R6/2TE/3TE  
Boccole pressare per 1SC/1SN/R6/2TE/3TE

DN	REFERENCIA PART N°	€
1/4"	ZSC21120400	
5/16"	ZSC21120500	
3/8"	ZSC21120600	
1/2"	ZSC21120800	
3/4"	ZSC21121200	
1"	ZSC21121600	



## Conexiones Standard

Embouts série standard  
Standard series  
Serie Standard

### Hembras giratorias rectas rosca BSP cono 60°

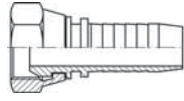

Femelle gaz cylindrique BSP 60°  
BSP Swivel female 60° cone  
Femmina diritta BSP sede 60°

DN	ROSCA THREAD	REFERENCIA PART N°	€
1/8"	1/8" BSP	841000202	
3/16"	1/8" BSP	841000203	
1/4"	1/8" BSP	841000204	
3/16"	1/4" BSP	841000403	
1/4"	1/4" BSP	841000404	
5/16"	1/4" BSP	841000405	
3/8"	1/4" BSP	841000406	
1/4"	3/8" BSP	841000604	
5/16"	3/8" BSP	841000605	
3/8"	3/8" BSP	841000606	
1/2"	3/8" BSP	841000608	
3/8"	1/2" BSP	841000806	
1/2"	1/2" BSP	841000808	
5/8"	1/2" BSP	841000810	
1/2"	5/8" BSP	841001008	
5/8"	5/8" BSP	841001010	
1/2"	3/4" BSP	841001208	
5/8"	3/4" BSP	841001210	
3/4"	3/4" BSP	841001212	
3/4"	1" BSP	841001612	
1"	1" BSP	841001616	
1"	1 1/4" BSP	841002016	
1" 1/4"	1" 1/4" BSP	841002020	
1" 1/4"	1" 1/2" BSP	841002420	
1" 1/2"	1" 1/2" BSP	841002424	
1 1/2"	2" BSP	841003224	
2"	2" BSP	841003232	

### Hembras giratorias 45° rosca BSP cono 60°

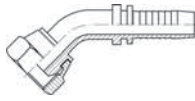

Coude 45° femelle gaz cyl. BSP 60°  
45° BSP Swivel female 60° cone  
Femmina 45° BSP sede 60°

DN	ROSCA THREAD	REFERENCIA PART N°	€
3/16"	1/4" BSP	841080403	
1/4"	1/4" BSP	841080404	
1/4"	3/8" BSP	841080604	
5/16"	3/8" BSP	841080605	
3/8"	3/8" BSP	841080606	
1/4"	1/2" BSP	841080804	
3/8"	1/2" BSP	841080806	
1/2"	1/2" BSP	841080808	
5/8"	5/8" BSP	841081010	
1/2"	3/4" BSP	841081208	
5/8"	3/4" BSP	841081210	
3/4"	3/4" BSP	841081212	
3/4"	1" BSP	841081612	
1"	1" BSP	841081616	
1" 1/4"	1" 1/4" BSP	841082020	
1" 1/2"	1" 1/2" BSP	841082424	
2"	2" BSP	841083232	

### Hembras giratorias 90° rosca BSP cono 60°

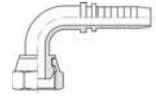

Coude 90° femelle gaz cyl. BSP 60°  
90° BSP Swivel female 60° cone  
Femmina 90° BSP sede 60°

DN	ROSCA THREAD	REFERENCIA PART N°	€
3/16"	1/4" BSP	841070403	
1/4"	1/4" BSP	841070404	
5/16"	1/4" BSP	841070405	
1/4"	3/8" BSP	841070604	
5/16"	3/8" BSP	841070605	
3/8"	3/8" BSP	841070606	
1/4"	1/2" BSP	841070804	
3/8"	1/2" BSP	841070806	
1/2"	1/2" BSP	841070808	
5/8"	5/8" BSP	841071010	
1/2"	3/4" BSP	841071208	
5/8"	3/4" BSP	841071210	
3/4"	3/4" BSP	841071212	
3/4"	1" BSP	841071612	
1"	1" BSP	841071616	
1" 1/4"	1" 1/4" BSP	841072020	
1" 1/2"	1" 1/2" BSP	841072424	
2"	2" BSP	841073232	

### Hembras giratorias 90° compactas rosca BSP cono 60°

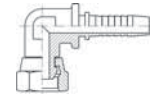

Femelle coudé 90° compact BSP cone 60°  
90° BSP Compact swivel female 60°  
Femmina 90° BSP compatta

DN	ROSCA THREAD	REFERENCIA PART N°	€
1/4"	1/4" BSP	841270404	
3/8"	3/8" BSP	841270606	
1/2"	1/2" BSP	841270808	
3/4"	3/4" BSP	841271212	
1"	1" BSP	841271616	

### Hembras giratorias rectas rosca BSP asiento plano

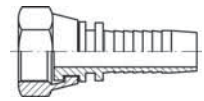

Femelle fond plat BSP  
BSP Swivel female flat seat  
Femmina BSP sede piana

DN	ROSCA THREAD	REFERENCIA PART N°	€
1/4"	1/4" BSP	842000404	
1/4"	3/8" BSP	842000604	
5/16"	3/8" BSP	842000605	
3/8"	3/8" BSP	842000606	
1/2"	3/8" BSP	842000608	
1/4"	1/2" BSP	842000804	
3/8"	1/2" BSP	842000806	
1/2"	1/2" BSP	842000808	
1/2"	3/4" BSP	842001208	
5/8"	3/4" BSP	842001210	
3/4"	3/4" BSP	842001212	
1"	1" BSP	842001616	
1"	1" 1/4" BSP	842002016	
1" 1/4"	1" 1/4" BSP	842002020	
1" 1/2"	1" 1/2" BSP	842002424	
2"	2" BSP	842003232	

## Conexiones Standard

Embouts série standard  
Standard series  
Serie Standard

### Hembras giratorias 90° rosca BSP asiento plano

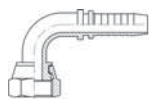

Coude 90° femelle fond plat BSP  
90° BSP Swivel female flat seat  
Femmina 90° BSP sede piana

DN	ROSCA THREAD	REFERENCIA PART N°	€
1/4"	1/4" BSP	842070404	
5/16"	3/8" BSP	842070605	
3/8"	3/8" BSP	842070606	
1/2"	1/2" BSP	842070808	
3/4"	3/4" BSP	842071212	
3/4"	1" BSP	842071612	
1"	1" BSP	842071616	
1"1/4"	1"1/4 BSP	842072020	
1"1/2"	1"1/2 BSP	842072424	
2"	2" BSP	842073232	

### Hembras giratorias 90° rosca BSP cono 60° con junta tórica

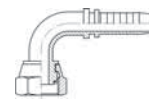

Coude 90° femelle gaz cyl. BSP 60° avec o-ring  
90° BSP Swivel female 60° cone with o-ring  
Femmina 90° BSP sede 60° con o'ring

DN	ROSCA THREAD	REFERENCIA PART N°	€
1/4"	1/4" BSP	841170404	
3/8"	3/8" BSP	841170606	
3/8"	1/2" BSP	841170806	
1/2"	1/2" BSP	841170808	
3/4"	3/4" BSP	841171208	
5/8"	3/4" BSP	841171210	
3/4"	3/4" BSP	841171212	
1"	1" BSP	841171616	
1"1/4"	1"1/4 BSP	841172020	
1"1/2"	1"1/2 BSP	841172424	
2"	2" BSP	841173232	

### Hembras giratorias 45° rosca BSP asiento plano

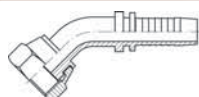

Coude 45° femelle fond plat BSP  
45° BSP Swivel female flat seat  
Femmina 45° BSP sede piana

DN	ROSCA THREAD	REFERENCIA PART N°	€
1/4"	1/4" BSP	842080404	
5/16"	3/8" BSP	842080605	
3/8"	3/8" BSP	842080606	
3/8"	1/2"	842080806	
1/2"	1/2" BSP	842080808	
3/4"	3/4" BSP	842081212	
3/4"	1" BSP	842081612	
1"	1" BSP	842081616	
1"1/4"	1"1/4 BSP	842082020	
1"1/2"	1"1/2 BSP	842082424	
2"	2" BSP	842083232	

### Hembras giratorias 45° rosca BSP cono 60° con junta tórica

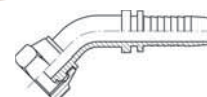

Coude 45° femelle gaz cyl. BSP 60° avec o-ring  
45° BSP Swivel female 60° cone with o-ring  
Femmina 45° BSP sede 60° con o'ring

DN	ROSCA THREAD	REFERENCIA PART N°	€
1/4"	1/4" BSP	841180404	
3/8"	3/8" BSP	841180606	
3/8"	1/2" BSP	841180806	
1/2"	1/2" BSP	841180808	
3/4"	3/4" BSP	841181208	
5/8"	3/4" BSP	841181210	
3/4"	3/4" BSP	841181212	
1"	1" BSP	841181616	
1"1/4"	1"1/4 BSP	841182020	
1"1/2"	1"1/2 BSP	841182424	
2"	2" BSP	841183232	

### Hembras giratorias rectas rosca BSP cono 60° con junta tórica

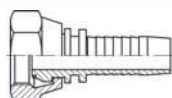

Femelle gaz cylindrique BSP 60° avec o-ring  
BSP Swivel female 60° cone with o-ring  
Femmina diritta BSP sede 60° con o'ring

DN	ROSCA THREAD	REFERENCIA PART N°	€
1/4"	1/4" BSP	841100404	
3/8"	3/8" BSP	841100606	
3/8"	1/2" BSP	841100806	
1/2"	1/2" BSP	841100808	
3/4"	3/4" BSP	841101208	
5/8"	3/4" BSP	841101210	
3/4"	3/4" BSP	841101212	
1"	1" BSP	841101616	
1"1/4"	1"1/4 BSP	841102020	
1"1/2"	1"1/2 BSP	841102424	
2"	2" BSP	841103232	

## Conexiones Standard

Embouts série standard  
Standard series  
Serie Standard

### Machos rosca cónica BSPT cono 60°

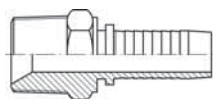

Mâle gaz conique BSPT 60°

Male BSP tapered

Maschio BSPT conico

DN	ROSCA THREAD	REFERENCIA PART N°	€
1/4"	1/4" BSPT	841140404	
5/16"	1/4" BSPT	841140405	
3/8"	1/4" BSPT	841140406	
1/4"	3/8" BSPT	841140604	
5/16"	3/8" BSPT	841140605	
3/8"	3/8" BSPT	841140606	
1/2"	3/8" BSPT	841140608	
3/8"	1/2" BSPT	841140806	
1/2"	1/2" BSPT	841140808	
1/2"	3/4" BSPT	841141208	
5/8"	3/4" BSPT	841141210	
3/4"	3/4" BSPT	841141212	
3/4"	1" BSPT	841141612	
1"	1" BSPT	841141616	
1"	1"1/4 BSPT	841142016	
1"1/4	1"1/4 BSPT	841142020	
1"1/4	1"1/2 BSPT	841142420	
1"1/2	1"1/2 BSPT	841142424	
2"	2" BSPT	841143232	

### Machos rosca cilíndrica BSP cono 60°



Mâle fixe BSP cône 60°

BSP Male-parallel-60° cone

Maschio BSP cilindrico sede 60°

DN	ROSCA THREAD	REFERENCIA PART N°	€
1/4"	1/8" BSP	841120204	
3/16"	1/4" BSP	841120403	
1/4"	1/4" BSP	841120404	
3/8"	1/4" BSP	841120406	
1/4"	3/8" BSP	841120604	
5/16"	3/8" BSP	841120605	
3/8"	3/8" BSP	841120606	
3/8"	1/2" BSP	841120806	
1/2"	1/2" BSP	841120808	
5/8"	5/8" BSP	841121010	
5/8"	3/4" BSP	841121210	
3/4"	3/4" BSP	841121212	
3/4"	1" BSP	841121612	
1"	1" BSP	841121616	
1"	1"1/4 BSP	841122016	
1"1/4	1"1/4 BSP	841122020	
1"1/4	1"1/2 BSP	841122420	
1"1/2	1"1/2 BSP	841122424	
2"	2" BSP	841123232	

### Macho rosca cilíndrica BSP asiento plano



Mâle BSP fond plat

BSP Male flat seat

Maschio BSP sede piana

DN	ROSCA THREAD	REFERENCIA PART N°	€
3/16"	1/4" BSP	842120403	
1/4"	1/4" BSP	842120404	
5/16"	3/8" BSP	842120605	
3/8"	3/8" BSP	842120606	
3/8"	1/2" BSP	842120806	
1/2"	1/2" BSP	842120808	
5/8"	5/8" BSP	842121010	
3/4"	3/4" BSP	842121212	
3/4"	1" BSP	842121612	
1"	1" BSP	842121616	
1"	1" 1/4 BSP	842122016	
1"1/4	1"1/4 BSP	842122020	
1"1/2	1"1/2 BSP	842122424	
2"	2" BSP	842123232	

## Conexiones Standard

Embouts série standard  
Standard series  
Serie Standard

### Hembras giratorias rectas rosca NPSM cono 60°



Femelle NPSM cone 60°  
NPSM Swivel female 60° cone  
Femmina diritta NPSM sede 60°

DN	ROSCA THREAD	REFERENCIA PART N°	€
1/4"	1/4" 18h NPSM	842610404	
3/8"	3/8" 18h NPSM	842610606	
1/2"	1/2" 14h NPSM	842610808	
3/4"	3/4" 14h NPSM	842611212	
1"	1" - 11 1/2 h NPSM	842611616	

### Machos rosca cónica NPT

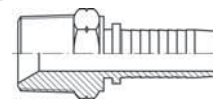

Embout mâle gaz conique NPT (BRIGGS)  
NPT Male thread  
Maschio NPT conico

DN	ROSCA THREAD	REFERENCIA PART N°	€
3/16"	1/8" NPT	841610203	
1/4"	1/8" NPT	841610204	
3/16"	1/4" NPT	841610403	
1/4"	1/4" NPT	841610404	
5/16"	1/4" NPT	841610405	
3/8"	1/4" NPT	841610406	
1/4"	3/8" NPT	841610604	
5/16"	3/8" NPT	841610605	
3/8"	3/8" NPT	841610606	
1/2"	3/8" NPT	841610608	
3/8"	1/2" NPT	841610806	
1/2"	1/2" NPT	841610808	
5/8"	1/2" NPT	841610810	
1/2"	3/4" NPT	841611208	
5/8"	3/4" NPT	841611210	
3/4"	3/4" NPT	841611212	
3/4"	1" NPT	841611612	
1"	1" NPT	841611616	
1"	1"1/4 NPT	841612016	
1"1/4	1"1/4 NPT	841612020	
1"1/4	1"1/2 NPT	841612420	
1"1/2	1"1/2 NPT	841612424	
2"	2" NPT	841613232	

### Hembras giratorias 90° rosca NPSM cono 60°

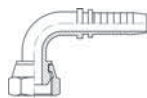

Coude 90° femelle NPSM cone 60°  
90° NPSM Swivel female 60° cone  
Femmina 90° NPSM sede 60°

DN	ROSCA THREAD	REFERENCIA PART N°	€
1/4"	1/4" 18h NPSM	842620404	
3/8"	3/8" 18h NPSM	842620606	
1/2"	1/2" 14h NPSM	842620808	
3/4"	3/4" 14h NPSM	842621212	
1"	1" - 11 1/2 h NPSM	842621616	

### Hembras giratorias 45° rosca NPSM cono 60°

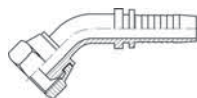

Coude 45° femelle NPSM cone 60°  
45° NPSM Swivel female 60° cone  
Femmina 45° NPSM sede 60°

DN	ROSCA THREAD	REFERENCIA PART N°	€
1/4"	1/4" 18h NPSM	842630404	
3/8"	3/8" 18h NPSM	842630606	
1/2"	1/2" 14h NPSM	842630808	
3/4"	3/4" 14h NPSM	842631212	
1"	1" - 11 1/2 h NPSM	842631616	

## Conexiones Standard

Embouts série standard  
Standard series  
Serie Standard

### Hembras giratorias rectas JIC 37°



Femelle droite JIC cone 37°  
JIC Swivel female cone 37°  
Femmina diritta JIC sede 37°

DN	ROSCA THREAD	REFERENCIA PART N°	€
3/16"	7/16" 20h UNF	841420703	
1/4"	7/16" 20h UNF	841420704	
3/16"	1/2" 20h UNF	841420803	
1/4"	1/2" 20h UNF	841420804	
5/16"	1/2" 20h UNF	841420805	
1/4"	9/16" 18h UNF	841420904	
5/16"	9/16" 18h UNF	841420905	
3/8"	9/16" 18h UNF	841420906	
3/8"	3/4" 16h UNF	841421206	
1/2"	3/4" 16h UNF	841421208	
3/8"	7/8" 14h UNF	841421406	
1/2"	7/8" 14h UNF	841421408	
5/8"	7/8" 14h UNF	841421410	
1/2"	1"1/16 12h UN	841421708	
5/8"	1"1/16 12h UN	841421710	
3/4"	1"1/16 12h UN	841421712	
1"	1"1/16 12h UN	841421716	
3/4"	1"5/16 12h UN	841422112	
1"	1"5/16 12h UN	841422116	
1"	1"5/8 12h UN	841422616	
1"1/4	1"5/8 12h UN	841422620	
1" 1/4	1"7/8 12h UN	841423020	
1"1/2	1"7/8 12h UN	841423024	
2"	2"1/2 12h UN	841424032	

### Hembras giratorias 45° JIC 37°

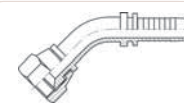

Coude 45° femelle JIC cone 37°  
45° JIC Swivel female cone 37°  
Femmina 45° JIC sede 37°

DN	ROSCA THREAD	REFERENCIA PART N°	€
3/16"	7/16" 20h UNF	841390703	
1/4"	7/16" 20h UNF	841390704	
1/4"	1/2" 20h UNF	841390804	
5/16"	1/2" 20h UNF	841390805	
1/4"	9/16" 18h UNF	841390904	
5/16"	9/16" 18h UNF	841390905	
3/8"	9/16" 18h UNF	841390906	
3/8"	3/4" 16h UNF	841391206	
1/2"	3/4" 16h UNF	841391208	
3/8"	7/8" 14h UNF	841391406	
1/2"	7/8" 14h UNF	841391408	
5/8"	7/8" 14h UNF	841391410	
5/8"	1"1/16 12h UN	841391710	
3/4"	1"1/16 12h UN	841391712	
3/4"	1"5/16 12h UN	841392112	
1"	1"5/16 12h UN	841392116	
1"	1"5/8 12h UN	841392616	
1"1/4	1"5/8 12h UN	841392620	
1"1/4	1"7/8 12h UN	841393020	
1"1/2	1"7/8 12h UN	841393024	
2"	2"1/2 12h UN	841394032	

### Hembras giratorias 90° JIC 37°

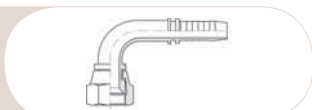

Coude 90° femelle JIC cone 37°  
90° JIC Swivel female cone 37°  
Femmina 90° JIC sede 37°

DN	ROSCA THREAD	REFERENCIA PART N°	€
3/16"	7/16" 20h UNF	841380703	
1/4"	7/16" 20h UNF	841380704	
1/4"	1/2" 20h UNF	841380804	
5/16"	1/2" 20h UNF	841380805	
1/4"	9/16" 18h UNF	841380904	
5/16"	9/16" 18h UNF	841380905	
3/8"	9/16" 18h UNF	841380906	
3/8"	3/4" 16h UNF	841381206	
1/2"	3/4" 16h UNF	841381208	
3/8"	7/8" 14h UNF	841381406	
1/2"	7/8" 14h UNF	841381408	
5/8"	7/8" 14h UNF	841381410	
5/8"	1"1/16 12h UN	841381710	
3/4"	1"1/16 12h UN	841381712	
3/4"	1" 5/16 12h UN	841382112	
1"	1"5/16 12h UN	841382116	
1"	1"5/8 12h UN	841382616	
1"1/4	1"5/8 12h UN	841382620	
1" 1/4	1" 7/8 12h UN	841383020	
1"1/2	1"7/8 12h UN	841383024	
2"	2"1/2 12h UN	841384032	

### Machos rosca JIC cono 37°

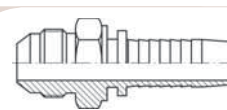

Mâle fixe JIC cone 37°  
Male JIC cone 37°  
Maschio JIC sede 37°

DN	ROSCA THREAD	REFERENCIA PART N°	€
1/4"	7/16" 20h UNF	841400704	
1/4"	1/2" 20h UNF	841400804	
5/16"	1/2" 20h UNF	841400805	
1/4"	9/16" 18h UNF	841400904	
5/16"	9/16" 18h UNF	841400905	
3/8"	9/16" 18h UNF	841400906	
1/4"	3/4" 16h UNF	841401204	
3/8"	3/4" 16h UNF	841401206	
1/2"	3/4" 16h UNF	841401208	
3/8"	7/8" 14h UNF	841401406	
1/2"	7/8" 14h UNF	841401408	
5/8"	7/8" 14h UNF	841401410	
5/8"	1"1/16 12h UN	841401710	
3/4"	1"1/16 12h UN	841401712	
1"	1"1/16 12h UN	841401716	
3/4"	1"5/16 12h UN	841402112	
1"	1"5/16 12h UN	841402116	
1"	1"5/8 12h UN	841402616	
1"1/4	1"5/8 12h UN	841402620	
1"1/2	1"7/8 12h UN	841403024	
2"	2"1/2 12h UN	841404032	

## Conexiones Standard

Embouts série standard  
Standard series  
Serie Standard

### Machos rosca JIC cono 37° con junta

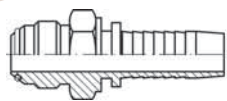

Mâle fixe JIC cono 37° avec o'ring  
Male JIC cone 37° with o'ring  
Maschio JIC sede 37° con o'ring

DN	ROSCA THREAD	REFERENCIA PART N°	€
1/4"	7/16" 20h UNF	841410704	
3/8"	9/16" 18h UNF	841410906	
1/2"	3/4" 16h UNF	841411208	
3/4"	1"1/16 12h UN	841411712	
1"	1"5/16 12h UN	841412116	
1"1/4	1"5/8 12h UN	841412620	
1"1/2	1"7/8 12h UN	841413024	
2"	2"1/2 12h UN	841414032	

### Hembras giratorias 90° compactas JIC 37°

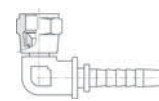

Femelle coudé 90° compact JIC cono 37°  
90° JIC Compact swivel cone 37°  
Femmina 90° JIC sede 37° compatta

DN	ROSCA THREAD	REFERENCIA PART N°	€
1/4"	7/16" 20h UNF	841370704	
3/8"	9/16" 18h UNF	841370906	
1/2"	3/4" 16h UNF	841371208	
3/4"	1"1/16 12h UN	841371712	
1"	1"5/16 12h UN	841372116	

### Hembras giratorias rectas rosca Métrica cono 24° con junta tórica - DKO

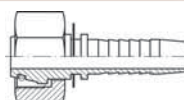

Femelle Métrique avec o'ring cône 24°  
Metric female swivel with o'ring 24° cone  
Femmina Metrica sede 24° con o'ring

DN	TUBO PIPE	SERIE	ROSCA THREAD	REFERENCIA PART N°	€
3/16"	6	L	M12x1.5	84804120603	
1/4"	6	L	M12x1.5	84804120604	
1/4"	8	L	M14x1.5	84804140804	
1/4"	10	L	M16x1.5	84804161004	
5/16"	10	L	M16x1.5	84804161005	
3/8"	10	L	M16x1.5	84804161006	
1/4"	12	L	M18x1.5	84804181204	
5/16"	12	L	M18x1.5	84804181205	
3/8"	12	L	M18x1.5	84804181206	
3/8"	15	L	M22x1.5	84804221506	
1/2"	15	L	M22x1.5	84804221508	
3/8"	18	L	M26x1.5	84804261806	
1/2"	18	L	M26x1.5	84804261808	
5/8"	18	L	M26x1.5	84804261810	
3/4"	22	L	M30x2	84804302212	
1"	28	L	M36x2	84804362816	
1"1/4	35	L	M45x2	84804453520	
1"1/2	42	L	M52x2	84804524224	
2"	42	L	M52x2	84804524232	
1/4"	6	S	M14x1.5	84804140604	
1/4"	8	S	M16x1.5	84804160804	
1/4"	10	S	M18x1.5	84804181004	
5/16"	10	S	M18x1.5	84804181005	
5/16"	12	S	M20x1.5	84804201205	
3/8"	12	S	M20x1.5	84804201206	
3/8"	14	S	M22x1.5	84804221406	
3/8"	16	S	M24x1.5	84804241606	
1/2"	16	S	M24x1.5	84804241608	
1/2"	20	S	M30x2	84804302008	
5/8"	20	S	M30x2	84804302010	
3/4"	20	S	M30x2	84804302012	
3/4"	25	S	M36x2	84804362512	
1"	25	S	M36x2	84804362516	
1"	30	S	M42x2	84804423016	
1"1/4	38	S	M52x2	84804523820	

### Machos rosca Métrica cono 24°

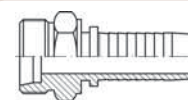

Mâle metrique cône 24°  
Metric stud 24° cone  
Maschio Metrico sede 24°

DN	TUBO PIPE	SERIE	ROSCA THREAD	REFERENCIA PART N°	€
1/4"	6	L	M12x1.5	84203120604	
1/4"	8	L	M14x1.5	84203140804	
1/4"	10	L	M16x1.5	84203161004	
5/16"	10	L	M16x1.5	84203161005	
3/8"	10	L	M16x1.5	84203161006	
1/4"	12	L	M18x1.5	84203181204	
5/16"	12	L	M18x1.5	84203181205	
3/8"	12	L	M18x1.5	84203181206	
3/8"	15	L	M22x1.5	84203221506	
1/2"	15	L	M22x1.5	84203221508	
1/2"	18	L	M26x1.5	84203261808	
5/8"	18	L	M26x1.5	84203261810	
3/4"	22	L	M30x2	84203302212	
1"	28	L	M36x2	84203362816	
1"1/4	35	L	M45x2	84203453520	
1"1/2	42	L	M52x2	84203524224	
1/4"	6	S	M14x1.5	84203140604	
1/4"	8	S	M16x1.5	84203160804	
1/4"	10	S	M18x1.5	84203181004	
5/16"	10	S	M18x1.5	84203181005	
3/8"	10	S	M18x1.5	84203181006	
5/16"	12	S	M20x1.5	84203201205	
3/8"	12	S	M20x1.5	84203201206	
3/8"	14	S	M22x1.5	84203221406	
1/2"	14	S	M22x1.5	84203221408	
1/2"	16	S	M24x1.5	84203241608	
5/8"	20	S	M30x2	84203302010	
3/4"	20	S	M30x2	84203302012	
3/4"	25	S	M36x2	84203362512	
1"	25	S	M36x2	84203362516	
1"	30	S	M42x2	84203423016	
1"1/4	38	S	M52x2	84203523820	

## Conexiones Standard

Embouts série standard  
Standard series  
Serie Standard

### Hembras giratorias 90° Métricas cono 24° con junta tórica - DKO 90°

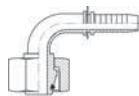

Coude 90° femelle Metrique cône 24° avec o'ring

90° Metric swivel female with o'ring 24° cone

Femmina Metrica 90° sede 24° con o'ring dado pinzato

DN	TUBO PIPE	SERIE	ROSCA THREAD	REFERENCIA PART N°	€
3/16"	6	L	M12x1.5	84305120603	
1/4"	6	L	M12x1.5	84305120604	
1/4"	8	L	M14x1.5	84305140804	
1/4"	10	L	M16x1.5	84305161004	
5/16"	10	L	M16x1.5	84305161005	
3/8"	10	L	M16x1.5	84305161006	
1/4"	12	L	M18x1.5	84305181204	
5/16"	12	L	M18x1.5	84305181205	
3/8"	12	L	M18x1.5	84305181206	
1/2"	15	L	M22x1.5	84305221508	
5/8"	18	L	M26x1.5	84305261810	
3/4"	22	L	M30x2	84305302212	
1"	28	L	M36x2	84305362816	
1" 1/4	35	L	M45x2	84305453520	
1" 1/2	42	L	M52x2	84305524224	
3/16"	6	S	M14x1.5	84305140603	
1/4"	6	S	M14x1.5	84305140604	
1/4"	8	S	M16x1.5	84305160804	
1/4"	10	S	M18x1.5	84305181004	
5/16"	12	S	M20x1.5	84305201205	
3/8"	12	S	M20x1.5	84305201206	
3/8"	14	S	M22x1.5	84305221406	
1/2"	16	S	M24x1.5	84305241608	
5/8"	20	S	M30x2	84305302010	
3/4"	20	S	M30x2	84305302012	
3/4"	25	S	M36x2	84305362512	
1"	25	S	M36x2	84305362516	
1"	30	S	M42x2	84305423016	
1" 1/4	38	S	M52x2	84305523820	

### Hembras giratorias 45° Métricas cono 24° con junta tórica - DKO 45°

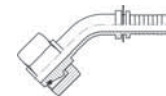

Coude 45° femelle Metrique cône 24° avec o'ring

45° Metric swivel female with o'ring 24° cone

Femmina Metrica 45° sede 24° con o'ring dado pinzato

DN	TUBO PIPE	SERIE	ROSCA THREAD	REFERENCIA PART N°	€
3/16"	6	L	M12x1.5	84306120603	
1/4"	6	L	M12x1.5	84306120604	
1/4"	8	L	M14x1.5	84306140804	
1/4"	10	L	M16x1.5	84306161004	
5/16"	10	L	M16x1.5	84306161005	
3/8"	10	L	M16x1.5	84306161006	
1/4"	12	L	M18x1.5	84306181204	
5/16"	12	L	M18x1.5	84306181205	
3/8"	12	L	M18x1.5	84306181206	
1/2"	15	L	M22x1.5	84306221508	
5/8"	18	L	M26x1.5	84306261810	
3/4"	22	L	M30x2	84306302212	
1"	28	L	M36x2	84306362816	
1" 1/4	35	L	M45x2	84306453520	
1" 1/2	42	L	M52x2	84306524224	
3/16"	6	S	M14x1.5	84306140603	
1/4"	6	S	M14x1.5	84306140604	
1/4"	8	S	M16x1.5	84306160804	
1/4"	10	S	M18x1.5	84306181004	
5/16"	12	S	M20x1.5	84306201205	
3/8"	12	S	M20x1.5	84306201206	
3/8"	14	S	M22x1.5	84306221406	
1/2"	16	S	M24x1.5	84306241608	
5/8"	20	S	M30x2	84306302010	
3/4"	20	S	M30x2	84306302012	
3/4"	25	S	M36x2	84306362512	
1"	25	S	M36x2	84306362516	
1"	30	S	M42x2	84306423016	
1" 1/4	38	S	M52x2	84306523820	

## Conexiones Standard

Embouts série standard  
Standard series  
Serie Standard

Crimp fittings for hoses

Pipe fittings DIN 2353

Flare fittings JIC  
SAE flanges

Adaptors

Welding fittings

Industrial fittings

Several items

### Hembras giratorias rectas rosca BSP cono 60° doble hexagonal



Femelle BSP cono 60° double hexagonal  
Double hexagonal BSP Swivel female cone 60°  
Femmina diritta BSP sede 60° doppio esagono

DN	ROSCA THREAD	REFERENCIA PART N°	€
1/4"	1/4" BSP	844000404	
5/16"	3/8" BSP	844000605	
3/8"	3/8" BSP	844000606	
1/2"	1/2" BSP	844000808	
3/4"	3/4" BSP	844001212	
1"	1" BSP	844001616	
1"1/4	1"1/4 BSP	844002020	
1"1/2	1"1/2 BSP	844002424	
2"	2" BSP	844003232	

### Hembras giratorias rectas JIC 37° doble hexagonal

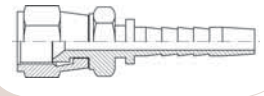

Femelle JIC 37° double hexagonal  
Double hexagonal JIC 37° Swivel female  
Femmina diritta JIC 37° doppio esagono

DN	ROSCA THREAD	REFERENCIA PART N°	€
1/4"	7/16" 20h UNF	842420704	
1/4"	1/2" 20h UNF	842420804	
5/16"	9/16" 18h UNF	842420905	
3/8"	9/16" 18h UNF	842420906	
3/8"	3/4" 16h UNF	842421206	
1/2"	3/4" 16h UNF	842421208	
1/2"	7/8" 14h UNF	842421408	
3/4"	1"1/16 12h UN	842421712	
1"	1"5/16 12h UN	842422116	
1"1/4	1"5/8 12h UN	842422620	
1"1/2	1"7/8 12h UN	842423024	
2"	2"1/2 12h UN	842424032	

### Hembras giratorias rectas rosca NPSM cono 60° doble hexagonal



Femelle NPSM cono 60° double hexagonal  
Double hexagonal NPSM Swivel female cone 60°  
Femmina diritta NPSM sede 60° doppio esagono

DN	ROSCA THREAD	REFERENCIA PART N°	€
1/4"	1/4" NPSM	843610404	
3/8"	3/8" 18h NPSM	843610606	
1/2"	1/2" 14h NPSM	843610808	
3/4"	3/4" NPSM	843611212	
1"	1" - 11 1/2 h NPSM	843611616	

### Espigas para Hidrolavadoras

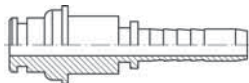

Embouts lisses pour hydronettoyages  
Standpipes for hidrowashing machines  
Inserti per idropulitrici

TUBO PIPE	ROSCA THREAD	REFERENCIA PART N°	€
5/16"	M 22x1.5	8305005	
3/8"	M 22x1.5	8305006	

### Tuercas para terminales Hidrolavadoras INOX



Écrous pour hydronettoyages  
Hexagonal nuts for hidrowashing machines  
Dado per idropulitrici

ROSCA THREAD	REFERENCIA PART N°	€
M22x1.5	KZTHAP22	



## Conexiones Standard

Embouts série standard  
Standard series  
Serie Standard

### Espigas lisas rectas Métricas

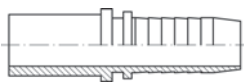

Embout lisse droit Métrique  
Metric standpipe for DIN 2353 fittings  
Estremità tubolare per raccordi DIN 2353

DN	TUBO PIPE	REFERENCIA PART N°	€
3/16"	6	841580603	
1/4"	6	841580604	
3/16"	8	841580803	
1/4"	8	841580804	
5/16"	8	841580805	
3/8"	8	841580806	
1/4"	10	841581004	
5/16"	10	841581005	
3/8"	10	841581006	
1/4"	12	841581204	
5/16"	12	841581205	
3/8"	12	841581206	
1/2"	12	841581208	
3/8"	14	841581406	
1/2"	14	841581408	
3/8"	15	841581506	
1/2"	15	841581508	
1/2"	16	841581608	
1/2"	18	841581808	
5/8"	18	841581810	
3/4"	18	841581812	
1/2"	20	841582008	
5/8"	20	841582010	
3/4"	20	841582012	
5/8"	22	841582210	
3/4"	22	841582212	
3/4"	25	841582512	
1"	25	841582516	
1"	28	841582816	
1"	30	841583016	
1"1/4	35	841583520	
1"1/4	38	841583820	
1"1/2	42	841584224	

### Espigas lisas rectas tubo gas

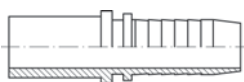

Embout lisse tube gaz  
Gas tube standpipes  
Estremità tubolare serie gas

DN	TUBO PIPE	REFERENCIA PART N°	€
1/4"	6.4	841590604	
3/8"	9.5	841590906	
3/8"	12.7	841591206	
1/2"	12.7	841591208	
5/8"	15.8	841591510	

### Espigas lisas 90° Métricas

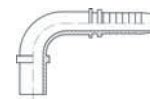

Embout lisse coude 90° Métrique  
90° Metric standpipe DIN 2353 fittings  
Estremità tubolare 90° per raccordi DIN 2353

DN	TUBO PIPE	REFERENCIA PART N°	€
1/8"	6	842580602	
3/16"	6	842580603	
1/4"	6	842580604	
3/16"	8	842580803	
1/4"	8	842580804	
5/16"	8	842580805	
1/4"	10	842581004	
5/16"	10	842581005	
3/8"	10	842581006	
1/4"	12	842581204	
5/16"	12	842581205	
3/8"	12	842581206	
1/2"	12	842581208	
3/8"	14	842581406	
1/2"	14	842581408	
3/8"	15	842581506	
1/2"	15	842581508	
1/2"	16	842581608	
1/2"	18	842581808	
5/8"	18	842581810	
5/8"	20	842582010	
3/4"	20	842582012	
5/8"	22	842582210	
3/4"	22	842582212	
3/4"	25	842582512	
1"	28	842582816	
1"	30	842583016	

\*Hasta fin de existencias / Jusqu'à la fin du stock / Until end of stock / Fino ad esaurimento scorta

### Espigas lisas 90° tubo gas

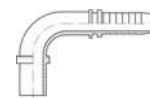

Embout lisse 90° tube gaz  
90° Gas tube standpipes  
Estremità tubolare 90° serie gas

DN	TUBO PIPE	REFERENCIA PART N°	€
1/4"	6.4	842590604	
3/8"	9.5	842590906	
1/2"	12.7	842591208	

## Conexiones Standard

Embouts série standard  
Standard series  
Serie Standard

### Espigas lisas 45° Métricas

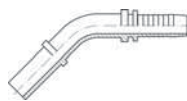

Embout lisse coude 45° Métrique  
45° Metric standpipe DIN 2353 fittings  
Estremità tubolare 45° per raccordi DIN 2353

DN	TUBO PIPE	REFERENCIA PART N°	€
3/16"	6	843580603	
1/4"	6	843580604	
3/16"	8	843580803	
1/4"	8	843580804	
5/16"	8	843580805	
1/4"	10	843581004	
5/16"	10	843581005	
3/8"	10	843581006	
1/4"	12	843581204	
5/16"	12	843581205	
3/8"	12	843581206	
1/2"	12	843581208	
3/8"	14	843581406	
1/2"	14	843581408	
1/2"	15	843581506	
1/2"	15	843581508	
1/2"	16	843581608	
1/2"	18	843581808	
5/8"	18	843581810	
5/8"	20	843582010	
1/2"	20	843582012	
5/8"	22	843582210	
3/4"	22	843582212	
3/4"	25	843582512	
1"	28	843582816	
1"	30	843583016	

### Espigas lisas 45° tubo gas

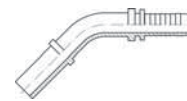

Embout lisse 45° tibe gaz  
45° Gas tube standpipes  
Estremità tubolare 45° serie gas

DN	TUBO PIPE	REFERENCIA PART N°	€
1/4"	6.4	843590604	
3/8"	9.5	843590906	
1/2"	12.7	843591208	

### Espigas de prensar dobles



Embout double jonction  
Double crimp standpipe  
Giunzione tubo-tubo

DN	REFERENCIA PART N°	€
1/4"	843000404	
5/16"	843000505	
3/8"	843000606	
1/2"	843000808	
3/4"	843001212	
1"	843001616	

### Espigas soldables

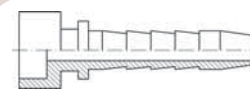

Embout lisse à souder  
Welding standpipes  
Inserti a saldare

DN	REFERENCIA PART N°	€
* 1/8"	840000200	
3/16"	840000300	
1/4"	840000400	
5/16"	840000500	
3/8"	840000600	
1/2"	840000800	
5/8"	840001000	
3/4"	840001200	
1"	840001600	
1"1/4	840002000	
1"1/2	840002400	
2"	840003200	
2"1/2	840004000	

\*Hasta fin de existencias/\*\*Jusqu'à la fin du stock/\*\*Until end of stock/\*\*Fino ad esaurimento scorta

## Conexiones Standard

Embouts série standard  
Standard series  
Serie Standard

### Orientables BSP

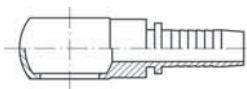

Banjo droit gaz BSP  
Banjo BSP  
Raccordo ad occhio BSP

DN	Ø	REFERENCIA PART N°	€
1/4"	1/4"	841110404	
5/16"	3/8"	841110605	
3/8"	3/8"	841110606	
1/2"	3/8"	841110608	
3/8"	1/2"	841110806	
1/2"	1/2"	841110808	
3/4"	3/4"	841111212	
1"	1"	841111616	

### Tornillo orientable simple BSP

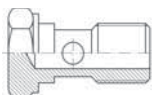

Vis creuse simple pour banjo gaz  
BSP Bolt for banjo  
Bullone forato BSP

ROSCA THREAD	REFERENCIA PART N°	€
1/4" BSP	Z109004	
3/8" BSP	Z109006	
1/2" BSP	Z109008	
3/4" BSP	Z109012	
1" BSP	Z109016	

Ver precios en p.141 (ADAPTADORES BSP)//Prix à la p.141 ADAPTEURS BSP//  
See prices in p.141 (BSP ADAPTORS)//Vedere prezzi p.141 (ADATTATORI BSP)

### Orientables Métricos

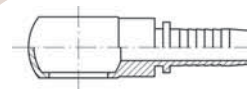

Banjo droit Métrique  
Banjo Metric  
Raccordo ad occhio Metrico

DN	Ø	REFERENCIA PART N°	€
1/4"	M12x1.5	841161204	
1/4"	M14x1.5	841161404	
5/16"	M16x1.5	841161605	
3/8"	M16x1.5	841161606	
3/8"	M18x1.5	841161806	
1/2"	M18x1.5	841161808	
1/2"	M20x1.5	841162008	
1/2"	M22x1.5	841162208	
3/4"	M26x1.5	841162612	

### Tornillo orientable simple Métrico

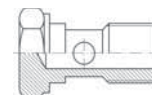

Vis creuse simple for banjo Métrique  
Metric bolt for banjo  
Bullone forato Metrico

ROSCA THREAD	REFERENCIA PART N°	€
M12X1.5	Z109212	
M14X1.5	Z109214	
M16X1.5	Z109216	
M18X1.5	Z109218	
M22X1.5	Z109222	
M26X1.5	Z109226	
M30X1.5	Z109230	

Ver precios en p.141 (ADAPTADORES BSP)//Prix à la p.141 ADAPTEURS BSP//  
See prices in p.141 (BSP ADAPTORS)//Vedere prezzi p.141 (ADATTATORI BSP)

## Conexiones Standard

Embouts série standard  
Standard series  
Serie Standard

### Bridas rectas SAE 3000 PSI

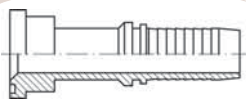

Bride SAE droite série 3000 PSI  
3000 PSI SAE Straight flange  
Flangia diritta SAE 3000

DN	Ø	REFERENCIA PART N°	€
1/2"	30,2	841820808	
1/2"	38,1	841821208	
5/8"	38,1	841821210	
3/4"	38,1	841821212	
3/4"	44,5	841821612	
1"	44,5	841821616	
1"	50,8	841822016	
1"1/4	50,8	841822020	
1"1/4	60,3	841822420	
1"1/2	60,3	841822424	
1"1/2	71,4	841823224	
2"	71,4	841823232	

### Bridas rectas SAE 6000 PSI

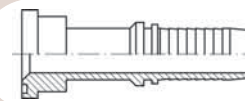

Bride SAE droite série 6000 PSI  
6000 PSI SAE Straight flange  
Flangia diritta SAE 6000

DN	Ø	REFERENCIA PART N°	€
1/2"	31,8	842820808	
1/2"	41,3	842821208	
5/8"	41,3	842821210	
3/4"	41,3	842821212	
3/4"	47,6	842821612	
1"	47,6	842821616	
1"	54	842822016	
1"1/4	54	842822020	
1"1/4	63,5	842822420	
1"1/2	63,5	842822424	
1"1/2	79,4	842823224	
2"	79,4	842823232	

### Bridas 90° SAE 3000 PSI

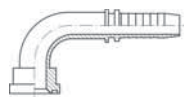

Bride SAE coude 90° série 3000 PSI  
3000 PSI SAE 90° Flange  
Flangia 90° SAE 3000

DN	Ø	REFERENCIA PART N°	€
1/2"	30,2	841830808	
1/2"	38,1	841831208	
5/8"	38,1	841831210	
3/4"	38,1	841831212	
3/4"	44,5	841831612	
1"	44,5	841831616	
1"	44,5	841831620	
1"	50,8	841832016	
1"1/4	50,8	841832020	
1"1/4	60,3	841832420	
1"1/2	60,3	841832424	
1"1/2	71,4	841833224	
2"	71,4	841833232	

### Bridas 90° SAE 6000 PSI

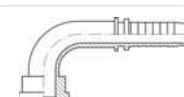

Bride SAE coude 90° série 6000 PSI  
6000 PSI SAE 90° Flange  
Flangia 90° SAE 6000

DN	Ø	REFERENCIA PART N°	€
1/2"	31,8	842830808	
1/2"	41,3	842831208	
5/8"	41,3	842831210	
3/4"	41,3	842831212	
3/4"	47,6	842831612	
1"	47,6	842831616	
1"	54	842832016	
1"1/4	54	842832020	
1"1/4	63,5	842832420	
1"1/2	63,5	842832424	
1"1/2	79,4	842833224	
2"	79,4	842833232	

### Bridas 45° SAE 3000 PSI



Bride SAE coude 45° série 3000 PSI  
3000 PSI SAE 45° Flange  
Flangia 45° SAE 3000

DN	Ø	REFERENCIA PART N°	€
1/2"	30,2	841840808	
1/2"	38,1	841841208	
5/8"	38,1	841841210	
3/4"	38,1	841841212	
3/4"	44,5	841841612	
1"	44,5	841841616	
1"	50,8	841842016	
1"1/4	50,8	841842020	
1"1/2	60,3	841842420	
1"1/2	60,3	841842424	
1"1/2	71,4	841843224	
2"	71,4	841843232	

### Bridas 45° SAE 6000 PSI

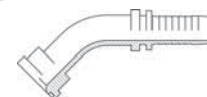

Bride SAE coude 45° série 6000 PSI  
6000 PSI SAE 45° flange  
Flangia 45° SAE 6000

DN	Ø	REFERENCIA PART N°	€
1/2"	31,8	842840808	
1/2"	41,3	842841208	
5/8"	41,3	842841210	
3/4"	41,3	842841212	
3/4"	47,6	842841612	
1"	47,6	842841616	
1"	54	842842016	
1"1/4	54	842842020	
1"1/4	63,5	842842420	
1"1/2	63,5	842842424	
1"1/2	79,4	842843224	
2"	79,4	842843232	

## Conexiones Standard

Embouts série standard  
Standard series  
Serie Standard

### Brida partida pasante

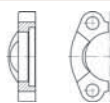

Demi-bride de fixation  
SAE Split flange  
Semiflangia SAE

SERIE	Ø in	TAMAÑO SIZE	REFERENCIA PART N°	€
3000 PSI	30.2	1/2"	ZBBP308302	
3000 PSI	38.1	3/4"	ZBBP312381	
3000 PSI	44.5	1"	ZBBP316445	
3000 PSI	50.8	1"1/4	ZBBP320508	
3000 PSI	60.3	1"1/2	ZBBP324603	
3000 PSI	71.4	2"	ZBBP332714	
3000 PSI	102.4	3"	ZBBP3481024	
6000 PSI	31.8	1/2"	ZBBP608318	
6000 PSI	41.3	3/4"	ZBBP612413	
6000 PSI	47.6	1"	ZBBP616476	
6000 PSI	54	1"1/4	ZBBP620540	
6000 PSI	63.5	1"1/2	ZBBP624635	
6000 PSI	79.4	2"	ZBBP632794	

### Brida entera pasante

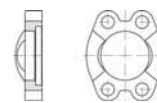

Bride de fixation monobloc  
SAE Flange  
Flangia monoblocco SAE

SERIE	Ø in	TAMAÑO SIZE	REFERENCIA PART N°	€
3000 PSI	30.2	1/2"	ZBBE308302	
3000 PSI	38.1	3/4"	ZBBE312381	
3000 PSI	44.5	1"	ZBBE316445	
3000 PSI	50.8	1"1/4	ZBBE320508	
3000 PSI	60.3	1"1/2	ZBBE324603	
3000 PSI	71.4	2"	ZBBE332714	
6000 PSI	31.8	1/2"	ZBBE608318	
6000 PSI	41.3	3/4"	ZBBE612413	
6000 PSI	47.6	1"	ZBBE616476	
6000 PSI	54	1"1/4	ZBBE620540	
6000 PSI	63.5	1"1/2	ZBBE624635	
6000 PSI	79.4	2"	ZBBE632794	

### Contrabrida roscada

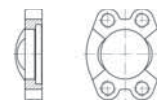

Contre-bride passage total  
SAE counter-flange  
Controflangia SAE

SERIE	Ø in	TAMAÑO SIZE	REFERENCIA PART N°	€
3000 PSI	30.2	1/2"	ZBCE308302	
3000 PSI	38.1	3/4"	ZBCE312381	
3000 PSI	44.5	1"	ZBCE316445	
3000 PSI	50.8	1"1/4	ZBCE320508	
3000 PSI	60.3	1"1/2	ZBCE324603	
3000 PSI	71.4	2"	ZBCE332714	
6000 PSI	31.8	1/2"	ZBCE608318	
6000 PSI	41.3	3/4"	ZBCE612413	
6000 PSI	47.6	1"	ZBCE616476	
6000 PSI	54	1"1/4	ZBCE620540	
6000 PSI	63.5	1"1/2	ZBCE624635	
6000 PSI	79.4	2"	ZBCE632794	

## Conexiones Standard

Embouts série standard  
Standard series  
Serie Standard

### Hembras giratorias rectas ORFS asiento plano

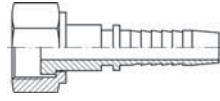

Femelle droite ORFS  
ORFS Swivel female straight  
Femmina diritta ORFS

DN	ROSCA THREAD	REFERENCIA PART N°	€
3/8"	13/16-16	849001306	
1/2"	13/16-16	849001308	
5/8"	1-14	849001610	
3/4"	1 7/16-12	849002312	
1"	1 7/16-12	849002316	
1 1/4"	1 11/16-12	849002720	
1 1/2"	2-12	849003224	

Hasta fin de existencias, después se servirá 84901...//Jusqu'à la fin du stock, après la référence à fournir sera 84901...//Until end of stocks, then we will send 84901...//Fino ad esaurimento scorte, dopo utilizzare cod. 84901...

### Hembras giratorias rectas ORFS doble Hex

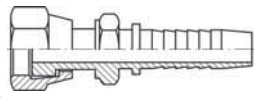

Femelle droite ORFS double hexagonal  
Double hexagonal ORFS Swivel female straight  
Femmina diritta ORFS doppio esagono

DN	ROSCA THREAD	REFERENCIA PART N°	€
1/4"	9/16-18	849010904	
1/4"	11/16-16	849011104	
5/16"	11/16-16	849011105	
3/8"	11/16-16	849011106	
3/8"	13/16-16	849011306	
1/2"	13/16-16	849011308	
1/2"	1-14	849011608	
5/8"	1-14	849011610	
1/2"	1 3/16-12	849011908	
3/4"	1 3/16-12	849011912	
3/4"	1 7/16-12	849012312	
1"	1 7/16-12	849012316	
1 1/4"	1 11/16-12	849012720	
1 1/2"	2-12	849013224	

### Machos ORFS

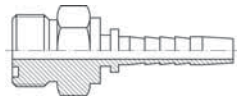

Mâle ORFS  
ORFS Male  
Maschio ORFS

DN	ROSCA THREAD	REFERENCIA PART N°	€
1/4"	9/16-18	849120904	
5/16"	11/16-16	849121105	
3/8"	11/16-16	849121106	
1/2"	13/16-16	849121308	
5/8"	1-14	849121610	
3/4"	1 3/16-12	849121912	
1"	1 7/16-12	849122316	
1 1/4"	1 11/16-12	849122720	
1 1/2"	2-12	849123224	

### Hembras giratorias 90° ORFS

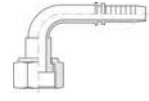

Coude 90° femelle ORFS  
90° ORFS Swivel female  
Femmina 90° ORFS

DN	ROSCA THREAD	REFERENCIA PART N°	€
1/4"	9/16-18	849070904	
1/4"	11/16-16	849071104	
5/16"	11/16-16	849071105	
3/8"	11/16-16	849071106	
3/8"	13/16-16	849071306	
1/2"	13/16-16	849071308	
1/2"	1-14	849071608	
5/8"	1-14	849071610	
3/4"	1 3/16-12	849071912	
3/4"	1 7/16-12	849072312	
1"	1 7/16-12	849072316	
1 1/4"	1 11/16-12	849072720	
1 1/2"	2-12	849073224	

### Hembras giratorias 45° ORFS

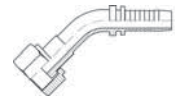

Coude 45° femelle ORFS  
45° ORFS Swivel female  
Femmina 45° ORFS

DN	ROSCA THREAD	REFERENCIA PART N°	€
1/4"	9/16-18	849080904	
1/4"	11/16-16	849081104	
5/16"	11/16-16	849081105	
3/8"	11/16-16	849081106	
3/8"	13/16-16	849081306	
1/2"	13/16-16	849081308	
1/2"	1-14	849081608	
5/8"	1-14	849081610	
3/4"	1 3/16-12	849081912	
3/4"	1 7/16-12	849082312	
1"	1 7/16-12	849082316	
1 1/4"	1 11/16-12	849082720	
1 1/2"	2-12	849083224	

### Macho O'Ring Boss

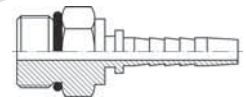

Mâle O'Ring Boss  
O'Ring Boss Male  
Maschio O'Ring Boss

DN	ROSCA THREAD	REFERENCIA PART N°	€
1/4"	7/16"-20h UNF	847120604	
3/8"	9/16"-18h UNF	847121006	
1/2"	3/4"-16h UNF	847121208	
5/8"	7/8"-14h UNF	847121610	
3/4"	1"1/16-12h UN	847122012	
1"	1"5/16-12h UN	847122516	

## Conexiones Interlock

Embouts Interlock  
Interlock series  
Serie Interlock

### Casquillos Interlock 4SH



Jupes à sertir DIN 20023 - 4SH Interlock

Ferrules DIN 20023 - 4SH Interlock

Boccola pressare per DIN 20023 - 4SH Interlock

DN	Descripción Description	REFERENCIA PART N°	€
3/4"	4SH / R13 / R15	Z610101200	
1"	4SH / R13 / R15	Z610101600	
1"1/4	4SH	Z610102000	
1"1/2	4SH	Z610102400	
2"	4SH	Z610103200	

### Casquillos Interlock R13/ R15

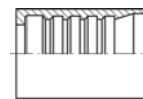

Jupes à sertir R13/R15 Interlock

Ferrules SAE 100 R13/R15 Interlock

Boccola pressare per SAE 100 R13/R15 Interlock

DN	REFERENCIA PART N°	€
1" 1/4	Z610102000	
1"1/2	Z610102400	
2"	Z610103200	

Para 3/4" y 1" son los mismos casquillos que en 4SH//3/4" et 1" sont les mêmes jupes que pour 4SH//3/4" and 1" are the same ferrules as in 4SH//Per 3/4" e 1" si utilizza la boccola 4SH

### Hembras giratorias rectas rosca BSP cono 60° Interlock

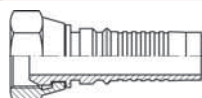

Femelle droite gaz cylindrique BSP 60° Interlock

BSP Swivel female 60° cone Interlock

Femmina diritta BSP sede 60° Interlock

DN	ROSCA THREAD	REFERENCIA PART N°	€
3/4"	3/4" BSP	Z641001212	
1"	1" BSP	Z641001616	
1"1/4	1"1/4 BSP	Z641002020	
1"1/2	1"1/2 BSP	Z641002424	
2"	2" BSP	Z641003232	

### Machos cilíndricos BSP 60° Interlock



Mâle gaz cylindrique BSP 60° Interlock

BSP Male 60° cone with Interlock o'ring

Maschio BSP cilindrico sede 60° Interlock

DN	ROSCA THREAD	REFERENCIA PART N°	€
3/4"	3/4" BSP	Z641121212	
1"	1" BSP	Z641121616	
1"1/4	1"1/4 BSP	Z641122020	
1"1/2	1"1/2 BSP	Z641122424	
2"	2" BSP	Z641123232	

### Hembras 90° BSP 60° Interlock

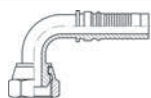

Coude 90° femelle gaz cylindrique BSP 60° Interlock

BSP Swivel female 90° 60° cone Interlock

Femmina 90° BSP sede 60° Interlock

DN	ROSCA THREAD	REFERENCIA PART N°	€
3/4"	3/4" BSP	Z641071212	
1"	1" BSP	Z641071616	
1"1/4	1"1/4 BSP	Z641072020	
1"1/2	1"1/2 BSP	Z641072424	
2"	2" BSP	Z641073232	

### Machos cónicos 60° NPT Interlock



Mâle conique NPT cone 60° Interlock

Con.NPT Male 60° cone Interlock

Maschio conico NPTsede 60° Interlock

DN	ROSCA THREAD	REFERENCIA PART N°	€
3/4"	3/4" NPT	Z641611212	
1"	1" NPT	Z641611616	
1"1/4	1"1/4 NPT	Z641612020	
1"1/2	1"1/2 NPT	Z641612424	
2"	2" NPT	Z641613232	

### Hembras 45° BSP 60° Interlock

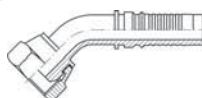

Coude 45° femelle gaz cylindrique BSP 60° Interlock

BSP Swivel female 45° 60° cone Interlock

Femmina 45° BSP sede 60° Interlock

DN	ROSCA THREAD	REFERENCIA PART N°	€
3/4"	3/4" BSP	Z641081212	
1"	1" BSP	Z641081616	
1"1/4	1"1/4 BSP	Z641082020	
1"1/2	1"1/2 BSP	Z641082424	
2"	2" BSP	Z641083232	

## Conexiones Interlock

Embouts Interlock  
Interlock series  
Serie Interlock

### Hembras giratorias rectas JIC 37° Interlock



Femelle tourn.droite JIC 37° Interlock  
37° JIC Swivel female Interlock  
Femmina gir.diritta JIC 37° Interlock

DN	ROSCA THREAD	REFERENCIA PART N°	€
3/4"	1"1/16 12h UN	Z641421712	
1"	1"5/16 12h UN	Z641422116	
1"1/4	1"5/8 12h UN	Z641422620	
1"1/4	1"7/8 12h UN	Z641423020	
1"1/2	1"7/8 12h UN	Z641423024	
2"	2"1/2 12h UN	Z641424032	

### Hembras giratorias 45° JIC 37° Interlock

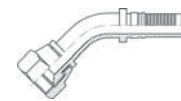

Coude 45° femelle tournante JIC 37° Interlock  
37° JIC 45° Swivel female Interlock  
Femmina gir. 45° JIC 37° Interlock

DN	ROSCA THREAD	REFERENCIA PART N°	€
3/4"	1"1/16 12h UN	Z641391712	
1"	1"5/16 12h UN	Z641392116	
1"1/4	1"5/8 12h UN	Z641392620	
1"1/2	1"7/8 12h UN	Z641393024	
2"	2"1/2 12h UN	Z641394032	

### Hembras giratorias 90° JIC 37° Interlock



Coude 90° femelle tournante JIC 37° Interlock  
37° JIC 90° Swivel female Interlock  
Femmina gir. 90° JIC 37° Interlock

DN	ROSCA THREAD	REFERENCIA PART N°	€
3/4"	1"1/16 12h UN	Z641381712	
1"	1"5/16 12h UN	Z641382116	
1"1/4	1"5/8 12h UN	Z641382620	
1"1/2	1"7/8 12h UN	Z641383024	
2"	2"1/2 12h UN	Z641384032	

### Machos JIC 37° Interlock



Mâle JIC 37° Interlock  
37° JIC male Interlock  
Maschio JIC 37° Interlock

DN	ROSCA THREAD	REFERENCIA PART N°	€
3/4"	1"1/16 12h UN	Z641401712	
1"	1"5/16 12h UN	Z641402116	
1"1/4	1"5/8 12h UN	Z641402620	
1"1/2	1"7/8 12h UN	Z641403024	
2"	2"1/2 12h UN	Z641404032	

### Hembras giratorias rectas Métricas cono 24° Interlock con junta tórica

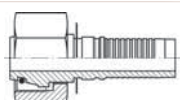

Femelle droite Métrique 24° Interlock avec o'ring  
Metric swivel female 24° seat serie S Interlock with o'ring  
Femmina Metrica sede 24° con o'ring serie S Interlock

DN	TUBO PIPE	SERIE	ROSCA THREAD	REFERENCIA PART N°	€
3/4"	20	S	M30x2	Z64204302012	
3/4"	25	S	M36x2	Z64204362512	
1"	30	S	M42x2	Z64204423016	
1"1/4	38	S	M52x2	Z64204523820	

### Hembras 45° Métricas cono 24° Interlock con junta tórica

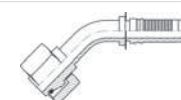

Coude 45° femelle Métrique 24° Interlock avec o'ring  
45° Metric swivel female 24° seat serie S Interlock with o'ring  
Femmina Metrica 45° sede 24° serie S Interlock

DN	TUBO PIPE	SERIE	ROSCA THREAD	REFERENCIA PART N°	€
3/4"	20	S	M30x2	Z64206302012	
3/4"	25	S	M36x2	Z64206362512	
1"	30	S	M42x2	Z64206423016	
1"1/4	38	S	M52x2	Z64206523820	

### Hembras 90° Métricas cono 24° Interlock con junta tórica

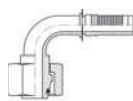

Coude 90° femelle Métrique 24° Interlock avec o'ring  
90° Metric swivel female 24° seat serie S Interlock with o'ring  
Femmina Metrica 90° sede 24° con o'ring serie S Interlock

DN	TUBO PIPE	SERIE	ROSCA THREAD	REFERENCIA PART N°	€
3/4"	20	S	M30x2	Z64205302012	
3/4"	25	S	M36x2	Z64205362512	
1"	30	S	M42x2	Z64205423016	
1"1/4	38	S	M52x2	Z64205523820	

### Machos Métricos cono 24° Interlock

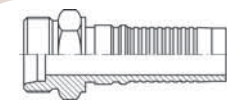

Mâle Métrique cono 24° Interlock  
Metric male stud 24° cone serie S Interlock  
Maschio Metrico sede 24° con o'ring serie S Interlock

DN	TUBO PIPE	SERIE	ROSCA THREAD	REFERENCIA PART N°	€
3/4"	20	S	M30x2	Z64203302012	
3/4"	25	S	M36x2	Z64203362512	
1"	30	S	M42x2	Z64203423016	
1"1/4	38	S	M52x2	Z64203523820	



## Conexiones Interlock

Embouts Interlock  
Interlock series  
Serie Interlock

### Hembras giratorias rectas ORFS Interlock

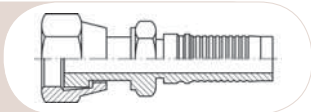

Femelle droite ORFS Interlock  
Interlock ORFS Swivel female straight  
Femmina diritta ORFS Interlock

DN	ROSCA THREAD	REFERENCIA PART N°	€
3/4"	1 3/16-12	Z649011912	
1"	1 7/16-12	Z649012316	
1 1/4"	1 11/16-12	Z649012720	
1 1/2"	2-12	Z649013224	

### Hembras giratorias 90° ORFS Interlock

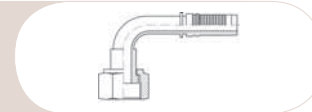

Coude 90° femelle ORFS Interlock  
Interlock 90° ORFS Swivel female  
Femmina 90° ORFS Interlock

DN	ROSCA THREAD	REFERENCIA PART N°	€
3/4"	1 3/16-12	Z649071912	
1"	1 7/16-12	Z649072316	
1 1/4"	1 11/16-12	Z649072720	
1 1/2"	2-12	Z649073224	

### Machos ORFS Interlock

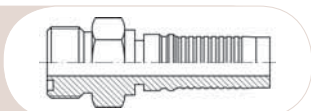

Mâle ORFS Interlock  
Interlock ORFS Male  
Maschio ORFS Interlock

DN	ROSCA THREAD	REFERENCIA PART N°	€
3/4"	1 3/16-12	Z649121912	
1"	1 7/16-12	Z649122316	
1 1/4"	1 11/16-12	Z649122720	
1 1/2"	2-12	Z649123224	

### Hembras giratorias 45° ORFS Interlock

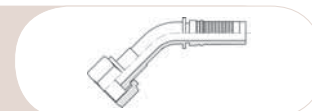

Coude 45° femelle ORFS Interlock  
Interlock 45° ORFS Swivel female  
Femmina 45° ORFS Interlock

DN	ROSCA THREAD	REFERENCIA PART N°	€
3/4"	1 3/16-12	Z649081912	
1"	1 7/16-12	Z649082316	
1 1/4"	1 11/16-12	Z649082720	
1 1/2"	2-12	Z649083224	

### Hembras giratorias BSP cono 60° doble hexagonal Interlock

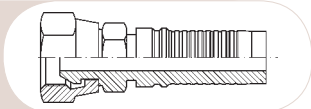

Femelle BSP cone 60° double hexagonal  
Double hexagonal BSP Swivel female cone 60°  
Femmina diritta BSP sede 60° doppio esagono

DN	ROSCA THREAD	REFERENCIA PART N°	€
3/4"	3/4" BSP	Z644001212	
1"	1" BSP	Z644001616	
1 1/4"	1 1/4" BSP	Z644002020	
1 1/2"	1 1/2" BSP	Z644002424	
2"	2" BSP	Z644003232	

### Hembras giratorias JIC 37° doble hexagonal Interlock

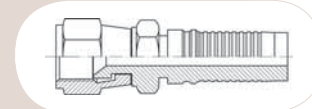

Femelle JIC 37° double hexagonal  
Double hexagonal JIC 37° Swivel female  
Femmina diritta JIC 37° doppio esagono

DN	ROSCA THREAD	REFERENCIA PART N°	€
3/4"	1 1/16 12h UN	Z642421712	
1"	1 5/16 12h UN	Z642422116	
1 1/4"	1 7/8 12h UN	Z642422620	
1 1/2"	1 7/8 12h UN	Z642423024	
2"	2 1/2 12h UN	Z642424032	

## Conexiones Interlock

Embouts Interlock  
Interlock series  
Serie Interlock

### Bridas rectas SAE 3000 PSI Interlock

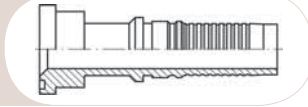

Bride SAE droite série 3000 PSI Interlock  
3000 PSI SAE Straight Flange Interlock  
Flangia diritta SAE 3000 Interlock

DN	Ø	REFERENCIA PART N°	€
3/4"	38.1	Z641821212	
3/4"	44.5	Z641821612	
1"	44.5	Z641821616	
1"	50.8	Z641822016	
1"1/4	50.8	Z641822020	
1"1/4	60.3	Z641822420	
1"1/2	60.3	Z641822424	
1"1/2	71.4	Z641823224	
2"	71.4	Z641823232	

### Bridas Rectas SAE 6000 PSI Interlock

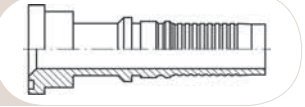

Bride SAE droite série 6000 PSI Interlock  
6000 PSI SAE Straight Flange  
Flangia diritta SAE 6000 Interlock

DN	Ø	REFERENCIA PART N°	€
3/4"	41,3	Z642821212	
3/4"	47,63	Z642821612	
1"	47,63	Z642821616	
1"	53,98	Z642822016	
1"1/4	54	Z642822020	
1"1/4	63,5	Z642822420	
1"1/2	63,5	Z642822424	
1"1/2	79,38	Z642823224	
2"	79,38	Z642823232	

### Bridas 90° SAE 3000 PSI Interlock

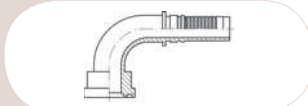

Coude 90° bride SAE série 3000 PSI Interlock  
3000 PSI SAE 90° Flange Interlock  
Flangia 90° SAE 3000 Interlock

DN	Ø	REFERENCIA PART N°	€
3/4"	38,1	Z641831212	
3/4"	44,45	Z641831612	
1"	44,45	Z641831616	
1"	50,8	Z641832016	
1"1/4	50,8	Z641832020	
1"1/4	60,33	Z641832420	
1" 1/2	60,33	Z641832424	
1" 1/2	71.4	Z641833224	
2"	71,4	Z641833232	

### Bridas 90° SAE 6000 PSI Interlock

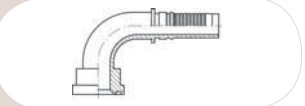

Coude 90° bride SAE série 6000 PSI Interlock  
6000 PSI SAE 90° Flange Interlock  
Flangia 90° SAE 6000 Interlock

DN	Ø	REFERENCIA PART N°	€
3/4"	41,28	Z642831212	
3/4"	44,45	Z642831612	
1"	47,63	Z642831616	
1"	53,98	Z642832016	
1"1/4	53,98	Z642832020	
1"1/4	63,5	Z642832420	
1"1/2	63,5	Z642832424	
1"1/2	79,38	Z642833224	
2"	79,38	Z642833232	

### Bridas 45° SAE 3000 PSI Interlock

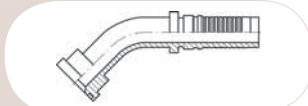

Coude 45° bride SAE série 3000 PSI Interlock  
3000 PSI SAE 45° Flange Interlock  
Flangia 45° SAE 3000 Interlock

DN	Ø	REFERENCIA PART N°	€
3/4"	38,1	Z641841212	
3/4"	44,5	Z641841612	
1"	44,5	Z641841616	
1"	50,8	Z641842016	
1"1/4	50,8	Z641842020	
1"1/4	60,3	Z641842420	
1" 1/2	60,3	Z641842424	
2"	71.4	Z641843232	

### Bridas 45° SAE 6000 PSI Interlock

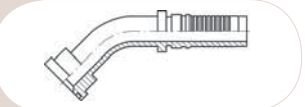

Coude 45° bride SAE série 6000 PSI Interlock  
6000 PSI SAE 45° Flange Interlock  
Flangia 45° SAE 6000 Interlock

DN	Ø	REFERENCIA PART N°	€
3/4"	41,3	Z642841212	
3/4"	47,6	Z642841612	
1"	47,6	Z642841616	
1"	54	Z642842016	
1"1/4	54	Z642842020	
1"1/4	63,5	Z642842420	
1"1/2	63,5	Z642842424	
1"1/2	79,4	Z642843224	
2"	79,4	Z642843232	

# Serie Compacta

Série Pré-sertis | One Piece Series | Serie Compatti

- **Conexiones Compactas Serie 43 R1AT/R2AT/1SN/2SN/R16/R17/2SC** | Embouts pré-sertis R1AT/R2AT/1SN/2SN/R16/R17/2SC Série 43 | One piece fittings 43 Series R1AT/R2AT/1SN/2SN/R16/R17/2SC | Raccordi compatti R1AT/R2AT/1SN/2SN/R16/R17/2SC Serie 43

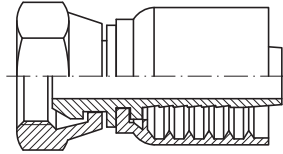

EN 853 1SN SAE 100 R1AT	EN 853 2 SN SAE 100 R2AT	EN 857 2SC SAE 100 R16	R17	SUPERSERVICE 155° 2SC
----------------------------------	-----------------------------------	---------------------------------	-----	-----------------------------

- **Conexiones Compactas R7/R8 y Elastómero malla metálica** | Embouts pré-sertis R7/R8 et Tresse métallique | piece fittings R7/R8 & Braid of steel wire | Raccordi compatti serie R7/R8 e elastomero treccia metallica

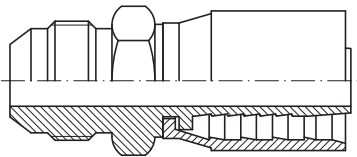

SAE 100 R7	SAE 100 R8	Metallic Braid Elastomer
---------------	---------------	--------------------------------

- **Conexiones Compactas PTFE Liso** | Embouts pré-sertis pour PTFE lisse | One piece fittings for Smooth PTFE | Raccordi compatti serie PTFE liscio

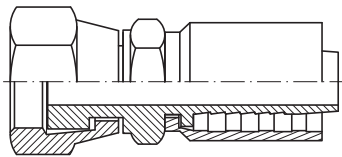

Smooth PTFE 1 Braid
---------------------------

- **Conexiones Compactas PTFE Corrugado** | Embouts pré-sertis pour PTFE convolute | One piece fittings for convoluted PTFE | Raccordi compatti serie PTFE involuto

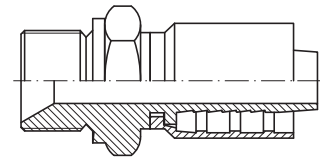

Convoluted PTFE
--------------------

- **Conexiones Compactas Serie BW R12/4SP/4SH** | Embouts pré-sertis R12/4SP/4SH Série BW | One piece fittings BW Series R12/4SP/4SH | Raccordi Compatti R12/4SP/4SH Serie BW

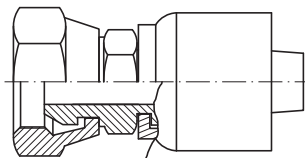

EN 856 R12	EN 856 4SP	4 SH
---------------	---------------	------

## Conexiones Compactas Serie 43 R1AT/R2AT/1SN/2SN/R16/R17/2SC

Embouts pré-sertis R1AT/R2AT/1SN/2SN/R16/R17/2SC Série 43

One piece fittings 43 Series R1AT/R2AT/1SN/2SN/R16/R17/2SC

Raccordi compatti R1AT/R2AT/1SN/2SN/R16/R17/2SC Serie 43

### Hembras giratorias rectas compactas JIC 37°

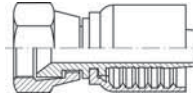

Femelle pré-sertie JIC 37°

One piece JIC 37° female

Femmina diritta compatta JIC 37°

DN	ROSCA THREAD	REFERENCIA PART N°	€
1/4"	7/16" 20h UNF	881420704	
3/8"	9/16" 18h UNF	881420906	
1/2"	3/4" 16h UNF	881421208	
5/8"	7/8" 14h UNF	881421410	
3/4"	1"1/16 12h UN	881421712	
1"	1"5/16 12h UN	881422116	
1"1/4"	1"5/8 12h UN	881422620	
1"1/2"	1"7/8 12h UN	881423024	
2"	2"1/2 12h UN	881424032	

### Hembras giratorias 45° compactas JIC 37°

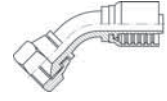

Coude 45° femelle pré-sertie JIC 37°

One piece JIC 37° female

Femmina 45° compatta JIC 37°

DN	ROSCA THREAD	REFERENCIA PART N°	€
1/4"	7/16" 20h UNF	881390704	
3/8"	9/16" 18h UNF	881390906	
1/2"	3/4" 16h UNF	881391208	
3/4"	1"1/16 12h UN	881391712	
1"	1"5/16 12h UN	881392116	
1"1/4"	1"5/8 12h UN	881392620	
1"1/2"	1"7/8 12h UN	881393024	
2"	2"1/2 12h UN	881394032	

### Hembras giratorias 90° compactas JIC 37°

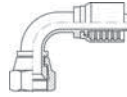

Coude 90° femelle pré-sertie JIC 37°

One piece JIC 37° 90° female

Femmina 90° compatta JIC 37°

DN	ROSCA THREAD	REFERENCIA PART N°	€
1/4"	7/16" 20h UNF	881380704	
3/8"	9/16" 18h UNF	881380906	
1/2"	3/4" 16h UNF	881381208	
1/2"	7/8" 14h UNF	881381408	
5/8"	7/8" 14h UNF	881381410	
3/4"	1"1/16 12h UN	881381712	
1"	1"5/16 12h UN	881382116	
1"1/4"	1"5/8 12h UN	881382620	
1"1/2"	1"7/8 12h UN	881383024	
2"	2"1/2 12h UN	881384032	

### Machos compactos rosca JIC 37°

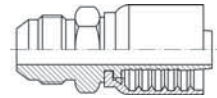

Mâle pré-serti JIC 37°

One piece JIC 37° male

Maschio compatto JIC sede 37°

DN	ROSCA THREAD	REFERENCIA PART N°	€
1/4"	7/16" 20h UNF	881400704	
3/8"	9/16" 18h UNF	881400906	
1/2"	3/4" 16h UNF	881401208	
3/4"	1"1/16 12h UN	881401712	
1"	1"5/16 12h UN	881402116	
1"1/4"	1"5/8 12h UN	881402620	
1"1/2"	1"7/8 12h UN	881403024	
2"	2"1/2 12h UN	881404032	

### Hembras giratorias rectas compactas JIC 37° doble hexagonal

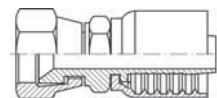

Femelle pré-sertie JIC 37° double hexagonal

One piece double hexagonal JIC 37° female

Femmina diritta JIC 37° doppio esagono

DN	ROSCA THREAD	REFERENCIA PART N°	€
1/4"	7/16" 20h UNF	882420704	
3/8"	9/16" 18h UNF	882420906	
1/2"	3/4" 16h UNF	882421208	
1/2"	7/8" 14h UNF	882421408	
3/4"	1"1/16 12h UN	882421712	
1"	1"5/16 12h UN	882422116	
1"1/4"	1"5/8 12h UN	882422620	
1"1/2"	1"7/8 12h UN	882423024	
2"	2"1/2 12h UN	882424032	

## Conexiones Compactas Serie 43 R1AT/R2AT/1SN/2SN/R16/R17/2SC

Embouts pré-sertis R1AT/R2AT/1SN/2SN/R16/R17/2SC Série 43

One piece fittings 43 Series R1AT/R2AT/1SN/2SN/R16/R17/2SC

Raccordi compatti R1AT/R2AT/1SN/2SN/R16/R17/2SC Serie 43

### Hembras giratorias rectas compactas ORFS doble hexagonal

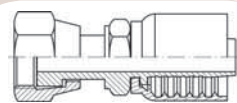

Femelle pré-sertie ORFS double hexagonal

One piece double hexagonal ORFS female

Femmina diritta compatta ORFS doppio esagono

DN	ROSCA THREAD	REFERENCIA PART N°	€
1/4"	9/16" 18h	889000904	
3/8"	11/16" 16h	889001106	
1/2"	13/16" 16h	889001308	
5/8"	1" 14h	889001610	
3/4"	1"3/16 12h	889001912	
1"	1"7/16 12h	889002316	
1"1/4	1"11/16 12h	889002720	
1"1/2	2" 12h	889003224	

### Hembras giratorias 45° compactas ORFS

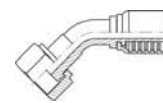

Coude 45° femelle pré-sertie ORFS

One piece 45° ORFS female

Femmina 45° compatta ORFS

DN	ROSCA THREAD	REFERENCIA PART N°	€
1/4"	9/16" 18h	889080904	
3/8"	11/16" 16h	889081106	
1/2"	13/16" 16h	889081308	
5/8"	1" 14h	889081610	
3/4"	1"3/16 12h	889081912	
1"	1"7/16 12h	889082316	
1"1/4	1"11/16 12h	889082720	
1"1/2	2" 12h	889083224	

### Hembras giratorias 90° compactas ORFS

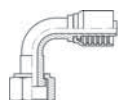

Coude 90° femelle pré-sertie ORFS

One piece 90° ORFS female

Femmina 90° compatta ORFS

DN	ROSCA THREAD	REFERENCIA PART N°	€
1/4"	9/16" 18h	889070904	
3/8"	11/16" 16h	889071106	
1/2"	13/16" 16h	889071308	
5/8"	1" 14h	889071610	
3/4"	1"3/16 12h	889071912	
1"	1"7/16 12h	889072316	
1"1/4	1"11/16 12h	889072720	
1"1/2	2" 12h	889073224	

### Machos compactos ORFS

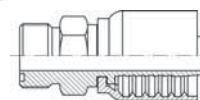

Mâle pré-serti ORFS

One piece ORFS male

Maschio compatto ORFS

DN	ROSCA THREAD	REFERENCIA PART N°	€
1/4"	9/16" 18h	889120904	
3/8"	11/16" 16h	889121106	
1/2"	13/16" 16h	889121308	
5/8"	1" 14h	889121610	
3/4"	1"3/16 12h	889121912	
1"	1"7/16 12h	889122316	
1"1/4	1"11/16 12h	889122720	
1"1/2	2" 12h	889123224	

## Conexiones Compactas Serie 43 R1AT/R2AT/1SN/2SN/R16/R17/2SC

Embouts pré-sertis R1AT/R2AT/1SN/2SN/R16/R17/2SC Série 43

One piece fittings 43 Series R1AT/R2AT/1SN/2SN/R16/R17/2SC

Raccordi compatti R1AT/R2AT/1SN/2SN/R16/R17/2SC Serie 43

### Hembras giratorias rectas compactas rosca NPSM cono 60°

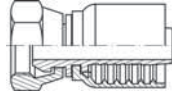

Femelle pré-sertie NPSM cono 60°

One piece NPSM female 60° cone

Femmina diritta compatta NPSM sede 60°

DN	ROSCA THREAD	REFERENCIA PART N°	€
1/4"	1/4" 18h NPSM	882610404	
3/8"	3/8" 18h NPSM	882610606	
1/2"	1/2" 14h NPSM	882610808	
3/4"	3/4" 14h NPSM	882611212	
1"	1" - 11 1/2 h NPSM	882611616	

### Machos compactos rosca cónica NPT

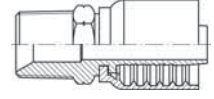

Mâle pré-serti NPT

One piece NPT male

Maschio compatto conico NPT

DN	ROSCA THREAD	REFERENCIA PART N°	€
1/4"	1/4" NPT	881610404	
3/8"	3/8" NPT	881610606	
1/2"	1/2" NPT	881610808	
3/4"	3/4" NPT	881611212	
1"	1" NPT	881611616	
1"1/4"	1"1/4 NPT	881612020	
1"1/2"	1"1/2 NPT	881612424	
2"	2" NPT	881613232	

### Hembras giratorias rectas compactas rosca NPSM cono 60° doble hexagonal

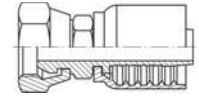

Femelle pré-sertie NPSM cono 60° double hexagonal

One piece double hexagonal NPSM female 60° cone

Femmina diritta compatta NPSM sede 60° doppio esagono

DN	ROSCA THREAD	REFERENCIA PART N°	€
1/4"	1/4" 18h NPSM	883610404	
3/8"	3/8" 18h NPSM	883610606	
1/2"	1/2" 14h NPSM	883610808	
3/4"	3/4" 14h NPSM	883611212	
1"	1" - 11 1/2 h NPSM	883611616	

### Hembras giratorias 90° compactas rosca NPSM cono 60°



Coude 90° femelle pré-sertie NPSM cono 60°

One piece 90° NPSM female 60° cone

Femmina 90° compatta NPSM sede 60°

DN	ROSCA THREAD	REFERENCIA PART N°	€
1/4"	1/4" 18h NPSM	882620404	
3/8"	3/8" 18h NPSM	882620606	
1/2"	1/2" 14h NPSM	882620808	
3/4"	3/4" 14h NPSM	882621212	
1"	1" - 11 1/2 h NPSM	882621616	

### Hembras giratorias 45° compactas rosca NPSM cono 60°

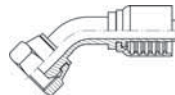

Coude 45° femelle pré-sertie NPSM cono 60°

One piece 45° NPSM female 60° cone

Femmina 45° compatta NPSM sede 60°

DN	ROSCA THREAD	REFERENCIA PART N°	€
1/4"	1/4" 18h NPSM	882630404	
3/8"	3/8" 18h NPSM	882630606	
1/2"	1/2" 14h NPSM	882630808	
3/4"	3/4" 14h NPSM	882631212	
1"	1" - 11 1/2 h NPSM	882631616	

## Conexiones Compactas Serie 43 R1AT/R2AT/1SN/2SN/R16/R17/2SC

Embouts pré-sertis R1AT/R2AT/1SN/2SN/R16/R17/2SC Série 43

One piece fittings 43 Series R1AT/R2AT/1SN/2SN/R16/R17/2SC

Raccordi compatti R1AT/R2AT/1SN/2SN/R16/R17/2SC Serie 43

### Bridas rectas compactas SAE 3000 PSI

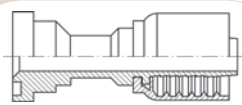

Bride SAE droite pré-sertie série 3000 PSI

One piece 3000 PSI SAE Straight Flange / Code 61

Flangia diritta compatta SAE 3000 PSI

DN	Ø	REFERENCIA PART N°	€
1/2"	30.2	881820808	
3/4"	38.1	881821212	
1"	44.5	881821616	
1"1/4	50.8	881822020	
1"1/2	60.3	881822424	
2"	71.4	881823232	

### Bridas rectas compactas SAE 6000 PSI

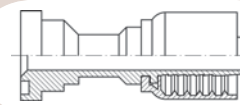

Bride SAE droite pré-sertie série 6000 PSI

One piece 6000 PSI SAE Straight Flange / Code 62

Flangia diritta compatta SAE 6000 PSI

DN	Ø	REFERENCIA PART N°	€
1/2"	31.8	882820808	
3/4"	41.3	882821212	
1"	47.6	882821616	
1"1/4	54	882822020	
1"1/2	63.5	882822424	
2"	79.4	882823232	

### Bridas 90° compactas SAE 3000 PSI

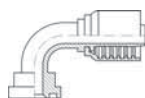

Bride SAE coude 90° pré-sertie série 3000 PSI

One piece 3000 PSI SAE 90° Flange / Code 61

Flangia 90° compatta SAE 3000 PSI

DN	Ø	REFERENCIA PART N°	€
1/2"	30.2	881830808	
3/4"	38.1	881831212	
1"	44.5	881831616	
1"1/4	50.8	881832020	
1"1/2	60.3	881832424	
2"	71.4	881833232	

### Bridas 90° compactas SAE 6000 PSI

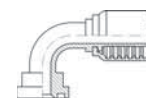

Bride SAE coude 90° pré-sertie série 6000 PSI

One piece 6000 PSI SAE 90° Flange / Code 62

Flangia 90° compatta SAE 6000 PSI

DN	Ø	REFERENCIA PART N°	€
1/2"	31.8	882830808	
3/4"	41.3	882831212	
1"	47.6	882831616	
1"1/4	54	882832020	
1"1/2	63.5	882832424	
2"	79.4	882833232	

### Bridas 45° compactas SAE 3000 PSI

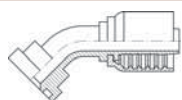

Bride SAE coude 45° pré-sertie série 3000 PSI

One piece 3000 PSI SAE 45° Flange / Code 61

Flangia 45° compatta SAE 3000 PSI

DN	Ø	REFERENCIA PART N°	€
1/2"	30.2	881840808	
3/4"	38.1	881841212	
1"	44.5	881841616	
1"1/4	50.8	881842020	
1"1/2	60.3	881842424	
2"	71.4	881843232	

### Bridas 45° compactas SAE 6000 PSI

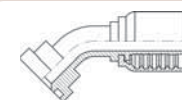

Bride SAE coude 45° pré-sertie série 6000 PSI

One piece 6000 PSI SAE 45° Flange / Code 62

Flangia 45° compatta SAE 6000 PSI

DN	Ø	REFERENCIA PART N°	€
1/2"	31.8	882840808	
3/4"	41.3	882841212	
1"	47.6	882841616	
1"1/4	54	882842020	
1"1/2	63.5	882842424	
2"	79.4	882843232	

# Conexiones Compactas Serie 43 R1AT/R2AT/1SN/2SN/R16/R17/2SC

Embouts pré-sertis R1AT/R2AT/1SN/2SN/R16/R17/2SC Série 43

One piece fittings 43 Series R1AT/R2AT/1SN/2SN/R16/R17/2SC

Raccordi compatti R1AT/R2AT/1SN/2SN/R16/R17/2SC Serie 43

## Hembras giratorias rectas compactas rosca Métrica cono 24° - DKO

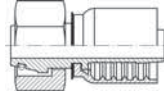

Femelle pré-sertie Métrique cone 24°

One piece Metric female cone 24°

Femmina diritta compatta Metrica sede 24°

DN	TUBO PIPE	SERIE	ROSCA THREAD	REFERENCIA PART N°	€
1/4"	6	L	M12x1.5	88804120604	
1/4"	8	L	M14x1.5	88804140804	
5/16"	10	L	M16x1.5	88804161005	
3/8"	12	L	M18x1.5	88804181206	
1/2"	15	L	M22x1.5	88804221508	
1/2"	18	L	M26x1.5	88804261808	
3/4"	22	L	M30x2	88804302212	
1"	28	L	M36x2	88804362816	
1 1/4"	35	L	M45x2	88804453520	
1 1/2"	42	L	M52x2	88804524224	
1/4"	8	S	M16x1.5	88804160804	
1/4"	10	S	M18x1.5	88804181004	
3/8"	12	S	M20x1.5	88804201206	
1/2"	16	S	M24x1.5	88804241608	
5/8"	20	S	M30x2	88804302010	
3/4"	20	S	M30x2	88804302012	
3/4"	25	S	M36x2	88804362512	
1"	25	S	M36x2	88804362516	
1"	30	S	M42x2	88804423016	
1 1/4"	38	S	M52x2	88804523820	

## Hembras giratorias 45° compactas Métricas cono 24° - DKO 45°

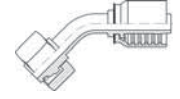

Coude 45° femelle pré-sertie Métrique cone 24°

One piece 45° Metric female cone 24°

Femmina 45° compatta Metrica sede 24°

DN	TUBO PIPE	SERIE	ROSCA THREAD	REFERENCIA PART N°	€
1/4"	6	L	M12x1.5	88306120604	
1/4"	8	L	M14x1.5	88306140804	
5/16"	10	L	M16x1.5	88306161005	
3/8"	10	L	M16x1.5	88306161006	
3/8"	12	L	M18x1.5	88306181206	
1/2"	15	L	M22x1.5	88306221508	
5/8"	18	L	M26x1.5	88306261810	
3/4"	22	L	M30x2	88306302212	
1"	28	L	M36x2	88306362816	
1 1/4"	35	L	M45x2	88306453520	
1 1/2"	42	L	M52x2	88306524224	
1/4"	8	S	M16x1.5	88306160804	
1/4"	10	S	M18x1.5	88306181004	
3/8"	12	S	M20x1.5	88306201206	
1/2"	16	S	M24x1.5	88306241608	
5/8"	20	S	M30x2	88306302010	
3/4"	20	S	M30x2	88306302012	
3/4"	25	S	M36x2	88306362512	
1"	25	S	M36x2	88306362516	
1"	30	S	M42x2	88306423016	
1 1/4"	38	S	M52x2	88306523820	

## Hembras giratorias 90° compactas Métricas cono 24° - DKO 90°

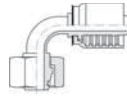

Coude 90° femelle pré-sertie Métrique cone 24°

One piece 90° Metric female cone 24°

Femmina 90° compatta Metrica sede 24°

DN	TUBO PIPE	SERIE	ROSCA THREAD	REFERENCIA PART N°	€
1/4"	6	L	M12x1.5	88305120604	
1/4"	8	L	M14x1.5	88305140804	
5/16"	10	L	M16x1.5	88305161005	
3/8"	12	L	M18x1.5	88305181206	
1/2"	15	L	M22x1.5	88305221508	
5/8"	18	L	M26x1.5	88305261810	
3/4"	22	L	M30x2	88305302212	
1"	28	L	M36x2	88305362816	
1 1/4"	35	L	M45x2	88305453520	
1 1/2"	42	L	M52x2	88305524224	
1/4"	8	S	M16x1.5	88305160804	
1/4"	10	S	M18x1.5	88305181004	
5/16"	12	S	M20x1.5	88305201205	
3/8"	12	S	M20x1.5	88305201206	
1/2"	16	S	M24x1.5	88305241608	
5/8"	20	S	M30x2	88305302010	
3/4"	20	S	M30x2	88305302012	
3/4"	25	S	M36x2	88305362512	
1"	25	S	M36x2	88305362516	
1"	30	S	M42x2	88305423016	
1 1/4"	38	S	M52x2	88305523820	

## Machos compactos rosca Métrica cono 24°

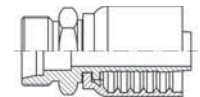

Mâle pré-serti Métrique cone 24°

One piece Metric male cone 24°

Maschio compatto Metrico sede 24°

DN	TUBO PIPE	SERIE	ROSCA THREAD	REFERENCIA PART N°	€
1/4"	6	L	M12x1.5	88203120604	
1/4"	8	L	M14x1.5	88203140804	
5/16"	10	L	M16x1.5	88203161005	
3/8"	10	L	M16x1.5	88203161006	
3/8"	12	L	M18x1.5	88203181206	
1/2"	15	L	M22x1.5	88203221508	
3/4"	22	L	M30x2	88203302212	
1"	28	L	M36x2	88203362816	
1 1/4"	35	L	M45x2	88203453520	
1 1/2"	42	L	M52x2	88203524224	
1/4"	8	S	M16x1.5	88203160804	
1/4"	10	S	M18x1.5	88203181004	
3/8"	12	S	M20x1.5	88203201206	
1/2"	16	S	M24x1.5	88203241608	
5/8"	20	S	M30x2	88203302010	
3/4"	20	S	M30x2	88203302012	
3/4"	25	S	M36x2	88203362512	
1"	25	S	M36x2	88203362516	
1"	30	S	M42x2	88203423016	
1 1/4"	38	S	M52x2	88203523820	



## Conexiones Compactas Serie 43 R1AT/R2AT/1SN/2SN/R16/R17/2SC

Embouts pré-sertis R1AT/R2AT/1SN/2SN/R16/R17/2SC Série 43

One piece fittings 43 Series R1AT/R2AT/1SN/2SN/R16/R17/2SC

Raccordi compatti R1AT/R2AT/1SN/2SN/R16/R17/2SC Serie 43

### Hembras giratorias rectas compactas rosca BSP cono 60°

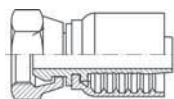

Femelle pré-sertie BSP cono 60°

One piece BSP female 60° cone

Femmina diritta compatta BSP sede 60°

DN	ROSCA THREAD	REFERENCIA PART N°	€
1/4"	1/4" BSP	881000404	
3/8"	3/8" BSP	881000606	
1/2"	1/2" BSP	881000808	
5/8"	1/2" BSP	881000810	
5/8"	5/8" BSP	881001010	
3/4"	3/4" BSP	881001212	
1"	1" BSP	881001616	
1"1/4	1"1/4 BSP	881002020	
1"1/2	1"1/2 BSP	881002424	
2"	2" BSP	881003232	

### Hembras giratorias 45° compactas rosca BSP cono 60°

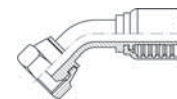

Coude 45° femelle pré-sertie BSP cono 60°

One piece 45° BSP female 60° cone

Femmina 45° compatta BSP sede 60°

DN	ROSCA THREAD	REFERENCIA PART N°	€
1/4"	1/4" BSP	881080404	
3/8"	3/8" BSP	881080606	
1/2"	1/2" BSP	881080808	
3/4"	3/4" BSP	881081212	
1"	1" BSP	881081616	
1"1/4	1"1/4 BSP	881082020	
1"1/2	1"1/2 BSP	881082424	
2"	2" BSP	881083232	

### Hembras giratorias 90° compactas rosca BSP cono 60°

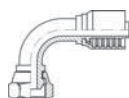

Coude 90° femelle pré-sertie BSP cono 60°

One piece 90° BSP female cone 60°

Femmina 90° compatta BSP sede 60°

DN	ROSCA THREAD	REFERENCIA PART N°	€
1/4"	1/4" BSP	881070404	
3/8"	3/8" BSP	881070606	
1/2"	1/2" BSP	881070808	
3/4"	3/4" BSP	881071212	
1"	1" BSP	881071616	
1"1/4	1"1/4 BSP	881072020	
1"1/2	1"1/2 BSP	881072424	
2"	2" BSP	881073232	

### Machos compactos rosca cilíndrica BSP cono 60°

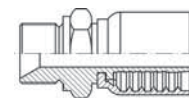

Mâle pré-serti BSP cono 60°

One piece BSP male 60° cone

Maschio compatto cilindrico BSP sede 60°

DN	ROSCA THREAD	REFERENCIA PART N°	€
1/4"	1/4" BSP	881120404	
3/8"	3/8" BSP	881120606	
3/8"	1/2" BSP	881120806	
1/2"	1/2" BSP	881120808	
3/4"	3/4" BSP	881121212	
1"	1" BSP	881121616	
1"1/4	1"1/4 BSP	881122020	
1"1/2	1"1/2 BSP	881122424	
2"	2" BSP	881123232	

### Hembras giratorias rectas compactas rosca BSP cono 60° doble hexagonal

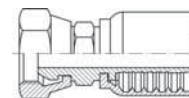

Femelle pré-sertie BSP cono 60° double hexagonal

One piece double hexagonal BSP female 60° cone

Femmina diritta compatta BSP sede 60° doppio esagono

DN	ROSCA THREAD	REFERENCIA PART N°	€
1/4"	1/4" BSP	884000404	
3/8"	3/8" BSP	884000605	
3/8"	3/8" BSP	884000606	
1/2"	1/2" BSP	884000808	
3/4"	3/4" BSP	884001212	
1"	1" BSP	884001616	
1"1/4	1"1/4 BSP	884002020	
1"1/2	1"1/2 BSP	884002424	
2"	2" BSP	884003232	

## Conexiones Compactas R7/R8 y Elastómero malla metálica

Embouts pré-sertis R7/R8 et Tresse métallique

One piece fittings R7/R8 & Braid of steel wire

Raccordi compatti serie R7/R8 e elastomero treccia metallica

### Hembras giratorias rectas compactas rosca JIC 37°

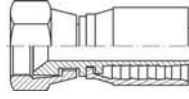

Femelle pré-sertie JIC 37°

One piece 37° JIC female

Femmina diritta compatta JIC 37°

DN	ROSCA THREAD	REFERENCIA PART N°	€
1/4"	7/16" 20h UNF	871420704	
1/4"	9/16" 18h UNF	871420904	
3/8"	9/16" 18h UNF	871420906	
1/2"	3/4" 16h UNF	871421208	
3/4"	1"1/16 12h UN	871421712	
1"	1"5/16 12h UN	871422116	

### Hembras giratorias 45° compactas rosca JIC 37°

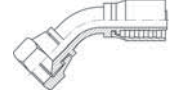

45° Femelle pré-sertie JIC 37°

One piece 37° JIC 45° female

Femmina 45° compatta JIC 37°

DN	ROSCA THREAD	REFERENCIA PART N°	€
1/4"	7/16" 20h UNF	871390704	
3/8"	9/16" 18h UNF	871390906	
1/2"	3/4" 16h UNF	871391208	
3/4"	1"1/16 12h UN	871391712	
1"	1"5/16 12h UN	871392116	

### Hembras giratorias 90° compactas rosca JIC 37°

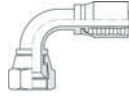

90° Femelle pré-sertie JIC 37°

One piece 37° JIC 90° female

Femmina 90° compatta JIC 37°

DN	ROSCA THREAD	REFERENCIA PART N°	€
1/4"	7/16" 20h UNF	871380704	
3/8"	9/16" 18h UNF	871380906	
1/2"	3/4" 16h UNF	871381208	
3/4"	1"1/16 12h UN	871381712	
1"	1"5/16 12h UN	871382116	

### Machos compactos rosca JIC 37°

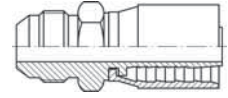

Mâle pré-serti JIC 37°

One piece 37° JIC male

Maschio compatto JIC sede 37°

DN	ROSCA THREAD	REFERENCIA PART N°	€
1/4"	7/16" 20h UNF	871400704	
3/8"	9/16" 18h UNF	871400906	
1/2"	3/4" 16h UNF	871401208	
3/4"	1"1/16 12h UN	871401712	
1"	1"5/16 12h UN	871402116	

### Hembras giratorias rectas compactas rosca JIC 37° doble hexagonal

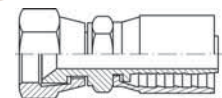

Femelle pré-sertie JIC 37° double hexagonal

One piece double hexagonal 37° JIC female

Femmina diritta JIC 37° doppio esagono

DN	ROSCA THREAD	REFERENCIA PART N°	€
1/4"	7/16" 20h UNF	872420704	
3/8"	9/16" 18h UNF	872420906	
1/2"	3/4" 16h UNF	872421208	
3/4"	1"1/16 12h UN	872421712	
1"	1"5/16 12h UN	872422116	

## Conexiones Compactas R7/R8 y Elastómero malla metálica

Embouts pré-sertis R7/R8 et Tresse métallique

One piece fittings R7/R8 & Braid of steel wire

Raccordi compatti serie R7/R8 e elastomero treccia metallica

### Hembras giratorias rectas compactas rosca ORFS doble hexagonal

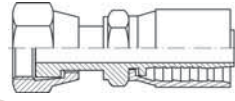

Femelle pré-sertie ORFS double hexagonal

One piece double hexagonal ORFS female

Femmina diritta compatta ORFS

DN	ROSCA THREAD	REFERENCIA PART N°	€
1/4"	9/16	879000904	
3/8"	11/16	879001106	
1/2"	13/16	879001308	
3/4"	1 3/16	879001912	
1"	1 7/16	879002316	

### Hembras giratorias 45° compactas rosca ORFS

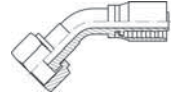

45° Femelle pré-sertie ORFS

One piece 45° ORFS female

Femmina 45° compatta ORFS

DN	ROSCA THREAD	REFERENCIA PART N°	€
1/4"	9/16	879080904	
3/8"	11/16	879081106	
1/2"	13/16	879081308	
3/4"	1 3/16	879081912	
1"	1 7/16	879082316	

### Hembras giratorias 90° compactas rosca ORFS

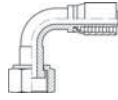

90° Femelle pré-sertie ORFS

One piece 90° ORFS female

Femmina 90° compatta ORFS

DN	ROSCA THREAD	REFERENCIA PART N°	€
1/4"	9/16	879070904	
3/8"	11/16	879071106	
1/2"	13/16	879071308	
3/4"	1 3/16	879071912	
1"	1 7/16	879072316	

### Machos compactos rosca ORFS

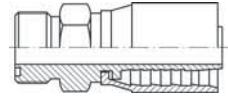

Mâle pré-serti ORFS

One piece ORFS male

Maschio compatto ORFS

DN	ROSCA THREAD	REFERENCIA PART N°	€
1/4"	9/16	879120904	
3/8"	11/16	879121106	
1/2"	13/16	879121308	
3/4"	1 3/16	879121912	
1"	1 7/16	879122316	

## Conexiones Compactas R7/R8 y Elastómero malla metálica

Embouts pré-sertis R7/R8 et Tresse métallique

One piece fittings R7/R8 & Braid of steel wire

Raccordi compatti serie R7/R8 e elastomero treccia metallica

### Hembras giratorias rectas compactas rosca NPSM cono 60°

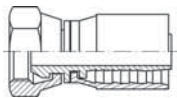

Femelle pré-sertie NPSM cono 60°

One piece NPSM female 60° cone

Femmina diritta compatta NPSM sede 60°

DN	ROSCA THREAD	REFERENCIA PART N°	€
1/4"	1/4" 18h NPSM	872610404	
3/8"	3/8" 18h NPSM	872610606	
1/2"	1/2" 14h NPSM	872610808	
3/4"	3/4" 14h NPSM	872611212	
1"	1" - 11 1/2 h NPSM	872611616	

### Machos compactos rosca cónica NPT

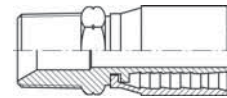

Mâle pré-serti NPT

One piece NPT male

Maschio compatto conico NPT

DN	ROSCA THREAD	REFERENCIA PART N°	€
1/4"	1/4" NPT	871610404	
3/8"	3/8" NPT	871610606	
1/2"	1/2" NPT	871610808	
3/4"	3/4" NPT	871611212	
1"	1" NPT	871611616	

### Hembras giratorias rectas compactas rosca NPSM cono 60° doble hexagonal

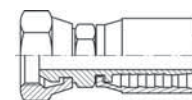

Femelle pré-sertie NPSM cono 60° double hexagonal

One piece double hexagonal NPSM female 60° cone

Femmina diritta compatta NPSM sede 60° doppio esagono

DN	ROSCA THREAD	REFERENCIA PART N°	€
1/4"	1/4" NPSM	873610404	
3/8"	3/8" 18h NPSM	873610606	
1/2"	1/2" 14h NPSM	873610808	
3/4"	3/4" NPSM	873611212	
1"	1" - 11 1/2 h NPSM	873611616	

### Hembras giratorias 90° compactas rosca NPSM cono 60°

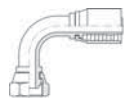

90° Femelle pré-sertie NPSM cono 60°

One piece 90° NPSM female 60° cone

Femmina 90° compatta NPSM sede 60°

DN	ROSCA THREAD	REFERENCIA PART N°	€
1/4"	1/4" 18h NPSM	872620404	
3/8"	3/8" 18h NPSM	872620606	
1/2"	1/2" 14h NPSM	872620808	
3/4"	3/4" 14h NPSM	872621212	
1"	1" - 11 1/2 h NPSM	872621616	

### Hembras giratorias 45° compactas rosca NPSM cono 60°

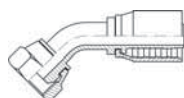

45° Femelle pré-sertie NPSM cono 60°

One piece 45° NPSM female 60° cone

Femmina 45° compatta NPSM sede 60°

DN	ROSCA THREAD	REFERENCIA PART N°	€
1/4"	1/4" 18h NPSM	872630404	
3/8"	3/8" 18h NPSM	872630606	
1/2"	1/2" 14h NPSM	872630808	
3/4"	3/4" 14h NPSM	872631212	
1"	1" - 11 1/2 h NPSM	872631616	

## Conexiones Compactas R7/R8 y Elastómero malla metálica

Embouts pré-sertis R7/R8 et Tresse métallique

One piece fittings R7/R8 & Braid of steel wire

Raccordi compatti serie R7/R8 e elastomero treccia metallica

### Hembras giratorias rectas compactas rosca Métrica cono 24° - DKO

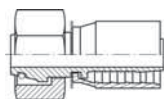

Femelle pré-sertie Métrique cone 24°

One piece Metric female 24° cone

Femmina diritta compatta Metrica sede 24°

DN	TUBO PIPE	SERIE	ROSCA THREAD	REFERENCIA PART N°	€
1/4"	8	L	M14x1.5	87804140804	
3/8"	12	L	M18x1.5	87804181206	
1/2"	15	L	M22x1.5	87804221508	
3/4"	22	L	M30x2	87804302212	
1"	28	L	M36x2	87804362816	
1/4"	8	S	M16x1.5	87804160804	
3/8"	12	S	M20x1.5	87804201206	
1/2"	16	S	M24x1.5	87804241608	
3/4"	20	S	M30x2	87804302012	
3/4"	25	S	M36x2	87804362512	
1"	30	S	M42x2	87804423016	

### Hembras giratorias 45° compactas Métricas cono 24° - DKO 45°

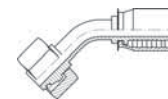

45° Femelle pré-sertie Métrique cone 24°

One piece 45° Metric female 24° cone

Femmina 45° compatta Metrica sede 24°

DN	TUBO PIPE	SERIE	ROSCA THREAD	REFERENCIA PART N°	€
1/4"	8	L	M14x1.5	87306140804	
3/8"	12	L	M18x1.5	87306181206	
1/2"	15	L	M22x1.5	87306221508	
3/4"	22	L	M30x2	87306302212	
1"	28	L	M36x2	87306362816	
1/4"	8	S	M16x1.5	87306160804	
3/8"	12	S	M20x1.5	87306201206	
1/2"	16	S	M24x1.5	87306241608	
3/4"	25	S	M36x2	87306362512	
1"	30	S	M42x2	87306423016	

### Hembras giratorias 90° compactas Métricas cono 24° - DKO 90°

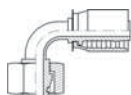

90° Femelle pré-sertie Métrique cone 24°

One piece 90° Metric female 24° cone

Femmina 90° compatta Metrica sede 24°

DN	TUBO PIPE	SERIE	ROSCA THREAD	REFERENCIA PART N°	€
1/4"	8	L	M14x1.5	87305140804	
3/8"	12	L	M18x1.5	87305181206	
1/2"	15	L	M22x1.5	87305221508	
3/4"	22	L	M30x2	87305302212	
1"	28	L	M36x2	87305362816	
1/4"	8	S	M16x1.5	87305160804	
3/8"	12	S	M20x1.5	87305201206	
1/2"	16	S	M24x1.5	87305241608	
3/4"	25	S	M36x2	87305362512	
1"	30	S	M42x2	87305423016	

### Machos compactos rosca Métrica cono 24°

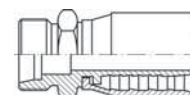

Mâle pré-serti Métrique cone 24°

One piece Metric male 24° cone

Maschio compatto Metrico sede 24°

DN	TUBO PIPE	SERIE	ROSCA THREAD	REFERENCIA PART N°	€
1/4"	8	L	M14x1.5	87203140804	
3/8"	12	L	M18x1.5	87203181206	
1/2"	15	L	M22x1.5	87203221508	
3/4"	22	L	M30x2	87203302212	
1"	28	L	M36x2	87203362816	
1/4"	8	S	M16x1.5	87203160804	
3/8"	12	S	M20x1.5	87203201206	
1/2"	16	S	M24x1.5	87203241608	
3/4"	25	S	M36x2	87203362512	
1"	30	S	M42x2	87203423016	

## Conexiones Compactas R7/R8 y Elastómero malla metálica

Embouts pré-sertis R7/R8 et Tresse métallique

One piece fittings R7/R8 & Braid of steel wire

Raccordi compatti serie R7/R8 e elastomero treccia metallica

### Hembras giratorias rectas compactas rosca BSP cono 60°

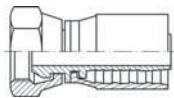

Femelle pré-sertie BSP cono 60°

One piece BSP female 60° cone

Femmina diritta compatta BSP sede 60°

DN	ROSCA THREAD	REFERENCIA PART N°	€
1/4"	1/4" BSP	871000404	
3/8"	3/8" BSP	871000606	
1/2"	1/2" BSP	871000808	
3/4"	3/4" BSP	871001212	
1"	1" BSP	871001616	

### Machos compactos rosca cilíndrica BSP cono 60°

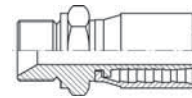

Mâle pré-serti BSP cono 60°

One piece BSP male 60° cone

Maschio compatto cilindrico BSP sede 60°

DN	ROSCA THREAD	REFERENCIA PART N°	€
1/4"	1/4" BSP	871120404	
3/8"	3/8" BSP	871120606	
1/2"	1/2" BSP	871120808	
3/4"	3/4" BSP	871121212	
1"	1" BSP	871121616	

### Hembras giratorias rectas compactas rosca BSP cono 60° doble hexagonal

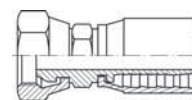

Femelle pré-sertie BSP cono 60° double hexagonal

One piece double hexagonal BSP female 60° cone

Femmina diritta compatta BSP sede 60° doppio esagono

DN	ROSCA THREAD	REFERENCIA PART N°	€
1/4"	1/4" BSP	874000404	
3/8"	3/8" BSP	874000606	
1/2"	1/2" BSP	874000808	
3/4"	3/4" BSP	874001212	
1"	1" BSP	874001616	

### Hembras giratorias 90° compactas rosca BSP cono 60°

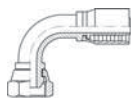

90° Femelle pré-sertie BSP cono 60°

One piece 90° BSP female 60° cone

Femmina 90° compatta BSP sede 60°

DN	ROSCA THREAD	REFERENCIA PART N°	€
1/4"	1/4" BSP	871070404	
3/8"	3/8" BSP	871070606	
1/2"	1/2" BSP	871070808	
3/4"	3/4" BSP	871071212	
1"	1" BSP	871071616	

### Hembras giratorias 45° compactas rosca BSP cono 60°

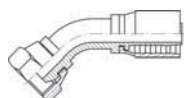

45° Femelle pré-sertie BSP cono 60°

One piece 45° BSP female 60° cone

Femmina 45° compatta BSP sede 60°

DN	ROSCA THREAD	REFERENCIA PART N°	€
1/4"	1/4" BSP	871080404	
3/8"	3/8" BSP	871080606	
1/2"	1/2" BSP	871080808	
3/4"	3/4" BSP	871081212	
1"	1" BSP	871081616	

## Conexiones Compactas PTFE Liso

Embouts pré-sertis pour PTFE lisse  
One piece fittings for Smooth PTFE  
Raccordi compatti serie PTFE liscio

### Hembras giratorias rectas compactas rosca JIC 37°

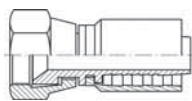

Femelle pré-sertie JIC 37°  
One piece 37° JIC female  
Femmina diritta compatta JIC 37°

DN	ROSCA THREAD	REFERENCIA PART N°	€
1/4"	7/16" 20h UNF	861420704	
3/8"	9/16" 18h UNF	861420906	
1/2"	3/4" 16h UNF	861421208	
3/4"	1"1/16 12h UN	861421712	
1"	1"5/16 12h UN	861422116	

### Machos compactos rosca JIC 37°

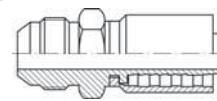

Mâle pré-serti JIC 37°  
One piece 37° JIC male  
Maschio compatto JIC sede 37°

DN	ROSCA THREAD	REFERENCIA PART N°	€
1/4"	7/16" 20h UNF	861400704	
3/8"	9/16" 18h UNF	861400906	
1/2"	3/4" 16h UNF	861401208	
3/4"	1"1/16 12h UN	861401712	
1"	1"5/16 12h UN	861402116	

### Hembras giratorias rectas compactas rosca JIC 37° doble hexagonal

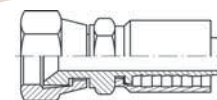

Femelle pré-sertie JIC 37° double hexagonal  
One piece 37° JIC double hexagonal female  
Femmina diritta JIC 37° doppio esagono

DN	ROSCA THREAD	REFERENCIA PART N°	€
1/4"	7/16" 20h UNF	862420704	
3/8"	9/16" 18h UNF	862420906	
1/2"	3/4" 16h UNF	862421208	
3/4"	1"1/16 12h UN	862421712	
1"	1"5/16 12h UN	862422116	

### Hembras giratorias 90° compactas rosca JIC 37°

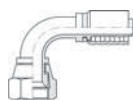

90° Femelle pré-sertie JIC 37°  
One piece 37° JIC 90° female  
Femmina 90° compatta JIC 37°

DN	ROSCA THREAD	REFERENCIA PART N°	€
1/4"	7/16" 20h UNF	861380704	
3/8"	9/16" 18h UNF	861380906	
1/2"	3/4" 16h UNF	861381208	
3/4"	1"1/16 12h UN	861381712	
1"	1"5/16 12h UN	861382116	

### Hembras giratorias 45° compactas rosca JIC 37°

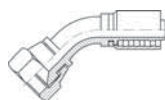

45° Femelle pré-sertie JIC 37°  
One piece 37° JIC 45° female  
Femmina 45° compatta JIC 37°

DN	ROSCA THREAD	REFERENCIA PART N°	€
1/4"	7/16" 20h UNF	861390704	
3/8"	9/16" 18h UNF	861390906	
1/2"	3/4" 16h UNF	861391208	
3/4"	1"1/16 12h UN	861391712	
1"	1"5/16 12h UN	861392116	

## Conexiones Compactas PTFE Liso

Embouts pré-sertis pour PTFE lisse  
One piece fittings for Smooth PTFE  
Raccordi compatti serie PTFE liscio

### Hembras giratorias rectas compactas rosca ORFS doble hexagonal

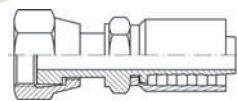

Femelle pré-sertie ORFS  
One piece ORFS female  
Femmina diritta compatta ORFS

DN	ROSCA THREAD	REFERENCIA PART N°	€
1/4"	9/16	869000904	
3/8"	11/16	869001106	
1/2"	13/16	869001308	
3/4"	1 3/16	869001912	
1"	1 7/16	869002316	

### Hembras giratorias 45° compactas rosca ORFS

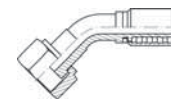

45° Femelle pré-sertie ORFS  
One piece 45° ORFS female  
Femmina 45° compatta ORFS

DN	ROSCA THREAD	REFERENCIA PART N°	€
1/4"	9/16	869080904	
3/8"	11/16	869081106	
1/2"	13/16	869081308	
3/4"	1 3/16	869081912	
1"	1 7/16	869082316	

### Hembras giratorias 90° compactas rosca ORFS



90° Femelle pré-sertie ORFS  
One piece 90° ORFS female  
Femmina 90° compatta ORFS

DN	ROSCA THREAD	REFERENCIA PART N°	€
1/4"	9/16	869070904	
3/8"	11/16	869071106	
1/2"	13/16	869071308	
3/4"	1 3/16	869071912	
1"	1 7/16	869072316	

### Machos compactos rosca ORFS

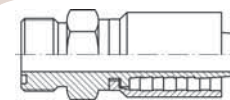

Mâle pré-serti ORFS  
One piece ORFS male  
Maschio compatto ORFS

DN	ROSCA THREAD	REFERENCIA PART N°	€
1/4"	9/16-18	869120904	
3/8"	11/16	869121106	
1/2"	13/16	869121308	
3/4"	1 3/16	869121912	
1"	1 7/16	869122316	



## Conexiones Compactas PTFE Liso

Embouts pré-sertis pour PTFE lisse  
One piece fittings for Smooth PTFE  
Raccordi compatti serie PTFE liscio

### Hembras giratorias rectas compactas rosca NPSM cono 60°

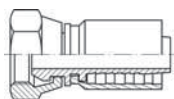

Femelle pré-sertie NPSM cono 60°  
One piece NPSM female 60° cone  
Femmina diritta compatta NPSM sede 60°

DN	ROSCA THREAD	REFERENCIA PART N°	€
1/4"	1/4" 18h NPSM	862610404	
3/8"	3/8" 18h NPSM	862610606	
1/2"	1/2" 14h NPSM	862610808	
3/4"	3/4" 14h NPSM	862611212	
1"	1" - 11 1/2 h NPSM	862611616	

### Machos compactos rosca cónica NPT

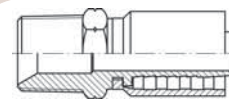

Mâle pré-serti NPT  
One piece NPT male  
Maschio compatto conico NPT

DN	ROSCA THREAD	REFERENCIA PART N°	€
1/4"	1/4" NPT	861610404	
3/8"	3/8" NPT	861610606	
1/2"	1/2" NPT	861610808	
3/4"	3/4" NPT	861611212	
1"	1" NPT	861611616	

### Hembras giratorias rectas compactas rosca NPSM cono 60° doble hexagonal

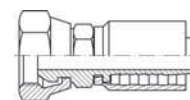

Femelle pré-sertie NPSM cono 60° double hexagonal  
One piece double hexagonal NPSM female 60° cone  
Femmina diritta compatta NPSM sede 60° doppio esagono

DN	ROSCA THREAD	REFERENCIA PART N°	€
1/4"	1/4" NPSM	863610404	
3/8"	3/8" 18h NPSM	863610606	
1/2"	1/2" 14h NPSM	863610808	
3/4"	3/4" NPSM	863611212	
1"	1" - 11 1/2 h NPSM	863611616	

### Hembras giratorias 90° compactas rosca NPSM cono 60°



90° Femelle pré-sertie NPSM cono 60°  
One piece 90° NPSM female 60° cone  
Femmina 90° compatta NPSM sede 60°

DN	ROSCA THREAD	REFERENCIA PART N°	€
1/4"	1/4" 18h NPSM	862620404	
3/8"	3/8" 18h NPSM	862620606	
1/2"	1/2" 14h NPSM	862620808	
3/4"	3/4" 14h NPSM	862621212	
1"	1" - 11 1/2 h NPSM	862621616	

### Hembras giratorias 45° compactas rosca NPSM cono 60°

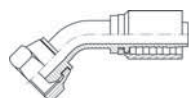

45° Femelle pré-sertie NPSM cono 60°  
One piece 45° NPSM female 60° cone  
Femmina 45° compatta NPSM sede 60°

DN	ROSCA THREAD	REFERENCIA PART N°	€
1/4"	1/4" 18h NPSM	862630404	
3/8"	3/8" 18h NPSM	862630606	
1/2"	1/2" 14h NPSM	862630808	
3/4"	3/4" 14h NPSM	862631212	
1"	1" - 11 1/2 h NPSM	862631616	

## Conexiones Compactas PTFE Liso

Embouts pré-sertis pour PTFE lisse  
One piece fittings for Smooth PTFE  
Raccordi compatti serie PTFE liscio

### Hembras giratorias rectas compactas rosca Métrica cono 24° - DKO

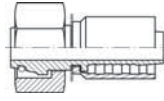

Femelle pré-sertie Métrique cone 24°

One piece Metric female 24° cone

Femmina diritta compatta Metrica sede 24°

DN	TUBO PIPE	SERIE	ROSCA THREAD	REFERENCIA PART N°	€
1/4"	8	L	M14x1.5	86804140804	
3/8"	12	L	M18x1.5	86804181206	
1/2"	15	L	M22x1.5	86804221508	
3/4"	22	L	M30x2	86804302212	
1"	28	L	M36x2	86804362816	
1/4"	8	S	M16x1.5	86804160804	
3/8"	12	S	M20x1.5	86804201206	
1/2"	16	S	M24x1.5	86804241608	
3/4"	25	S	M36x2	86804362512	
1"	30	S	M42x2	86804423016	

### Hembras giratorias 45° compactas rosca Métrica cono 24° - DKO 45°

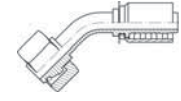

45° Femelle pré-sertie Métrique cone 24°

One piece 45° Metric female 24° cone

Femmina 45° compatta Metrica sede 24°

DN	TUBO PIPE	SERIE	ROSCA THREAD	REFERENCIA PART N°	€
1/4"	8	L	M14x1.5	86306140804	
3/8"	12	L	M18x1.5	86306181206	
1/2"	15	L	M22x1.5	86306221508	
3/4"	22	L	M30x2	86306302212	
1"	28	L	M36x2	86306362816	
1/4"	8	S	M16x1.5	86306160804	
3/8"	12	S	M20x1.5	86306201206	
1/2"	16	S	M24x1.5	86306241608	
3/4"	25	S	M36x2	86306362512	
1"	30	S	M42x2	86306423016	

### Hembras giratorias 90° compactas rosca Métrica cono 24° - DKO 90°

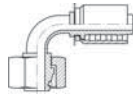

90° Femelle pré-sertie Métrique cone 24°

One piece 90° Metric female 24° cone

Femmina 90° compatta Metrica sede 24°

DN	TUBO PIPE	SERIE	ROSCA THREAD	REFERENCIA PART N°	€
1/4"	8	L	M14x1.5	86305140804	
3/8"	12	L	M18x1.5	86305181206	
1/2"	15	L	M22x1.5	86305221508	
3/4"	22	L	M30x2	86305302212	
1"	28	L	M36x2	86305362816	
1/4"	8	S	M16x1.5	86305160804	
3/8"	12	S	M20x1.5	86305201206	
1/2"	16	S	M24x1.5	86305241608	
3/4"	25	S	M36x2	86305362512	
1"	30	S	M42x2	86305423016	

### Machos compactos rosca Métrica cono 24°

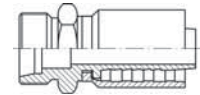

Mâle pré-serti Métrique cone 24°

One piece Metric male 24° cone

Maschio compatto Metrico sede 24°

DN	TUBO PIPE	SERIE	ROSCA THREAD	REFERENCIA PART N°	€
1/4"	8	L	M14x1.5	86203140804	
3/8"	12	L	M18x1.5	86203181206	
1/2"	15	L	M22x1.5	86203221508	
3/4"	22	L	M30x2	86203302212	
1"	28	L	M36x2	86203362816	
1/4"	8	S	M16x1.5	86203160804	
3/8"	12	S	M20x1.5	86203201206	
1/2"	16	S	M24x1.5	86203241608	
3/4"	25	S	M36x2	86203362512	
1"	30	S	M42x2	86203423016	

## Conexiones Compactas PTFE Liso

Embouts pré-sertis pour PTFE lisse  
One piece fittings for Smooth PTFE  
Raccordi compatti serie PTFE liscio

### Hembras giratorias rectas compactas rosca BSP cono 60°

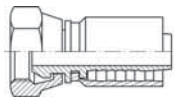

Femelle pré-sertie BSP cono 60°  
One piece BSP female 60° cone  
Femmina diritta compatta BSP sede 60°

DN	ROSCA THREAD	REFERENCIA PART N°	€
1/4"	1/4" BSP	861000404	
3/8"	3/8" BSP	861000606	
1/2"	1/2" BSP	861000808	
3/4"	3/4" BSP	861001212	
1"	1" BSP	861001616	

### Machos compactos rosca cilíndrica BSP cono 60°

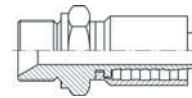

Mâle pré-serti BSP cono 60°  
One piece BSP male 60° cone  
Maschio compatto cilindrico BSP sede 60°

DN	ROSCA THREAD	REFERENCIA PART N°	€
1/4"	1/4" BSP	861120404	
3/8"	3/8" BSP	861120606	
1/2"	1/2" BSP	861120808	
3/4"	3/4" BSP	861121212	
1"	1" BSP	861121616	

### Hembras giratorias rectas compactas rosca BSP cono 60° doble hexagonal

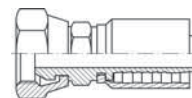

Femelle pré-sertie BSP cono 60° double hexagonal  
One piece double hexagonal BSP female 60° cone  
Femmina diritta compatta BSP sede 60° doppio esagono

DN	ROSCA THREAD	REFERENCIA PART N°	€
1/4"	1/4" BSP	864000404	
3/8"	3/8" BSP	864000606	
1/2"	1/2" BSP	864000808	
3/4"	3/4" BSP	864001212	
1"	1" BSP	864001616	

### Hembras giratorias 90° compactas rosca BSP cono 60°

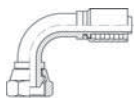

90° Femelle pré-sertie BSP cono 60°  
One piece 90° BSP female 60° cone  
Femmina 90° compatta BSP sede 60°

DN	ROSCA THREAD	REFERENCIA PART N°	€
1/4"	1/4" BSP	861070404	
3/8"	3/8" BSP	861070606	
1/2"	1/2" BSP	861070808	
3/4"	3/4" BSP	861071212	
1"	1" BSP	861071616	

### Hembras giratorias 45° compactas rosca BSP cono 60°

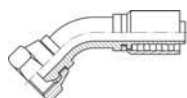

45° Femelle pré-sertie BSP cono 60°  
One piece 45° BSP female 60° cone  
Femmina 45° compatta BSP sede 60°

DN	ROSCA THREAD	REFERENCIA PART N°	€
1/4"	1/4" BSP	861080404	
3/8"	3/8" BSP	861080606	
1/2"	1/2" BSP	861080808	
3/4"	3/4" BSP	861081212	
1"	1" BSP	861081616	

## Conexiones Compactas PTFE Corrugado

Embouts pré-sertis pour PTFE convoluté  
One piece fittings for convoluted PTFE  
Raccordi compatti serie PTFE involuto

### Hembras giratorias rectas compactas rosca JIC 37°

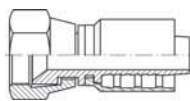

Femelle pré-sertie JIC 37°  
One piece 37° JIC female  
Femmina diritta compatta JIC 37°

DN	ROSCA THREAD	REFERENCIA PART N°	€
1/4"	7/16" 20h UNF	851420704	
3/8"	9/16" 18h UNF	851420906	
1/2"	3/4" 16h UNF	851421208	
3/4"	1"1/16 12h UN	851421712	
1"	1"5/16 12h UN	851422116	

### Machos compactos rosca JIC 37°

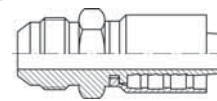

Mâle pré-serti JIC 37°  
One piece 37° JIC male  
Maschio compatto JIC sede 37°

DN	ROSCA THREAD	REFERENCIA PART N°	€
1/4"	7/16" 20h UNF	851400704	
3/8"	9/16" 18h UNF	851400906	
1/2"	3/4" 16h UNF	851401208	
3/4"	1"1/16 12h UN	851401712	
1"	1"5/16 12h UN	851402116	

### Hembras giratorias rectas compactas rosca JIC 37° doble hexagonal

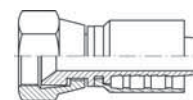

Femelle pré-sertie JIC 37° double hexagonal  
One piece 37° JIC double hexagonal female  
Femmina diritta JIC 37° doppio esagono

DN	ROSCA THREAD	REFERENCIA PART N°	€
1/4"	7/16" 20h UNF	852420704	
3/8"	9/16" 18h UNF	852420906	
1/2"	3/4" 16h UNF	852421208	
3/4"	1"1/16 12h UN	852421712	
1"	1"5/16 12h UN	852422116	

### Hembras giratorias 90° compactas rosca JIC 37°

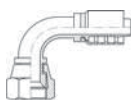

90° Femelle pré-sertie JIC 37°  
One piece 37° JIC 90° female  
Femmina 90° compatta JIC 37°

DN	ROSCA THREAD	REFERENCIA PART N°	€
1/4"	7/16" 20h UNF	851380704	
3/8"	9/16" 18h UNF	851380906	
1/2"	3/4" 16h UNF	851381208	
3/4"	1"1/16 12h UN	851381712	
1"	1"5/16 12h UN	851382116	

### Hembras giratorias 45° compactas rosca JIC 37°



45° Femelle pré-sertie JIC 37°  
One piece 37° JIC 45° female  
Femmina 45° compatta JIC 37°

DN	ROSCA THREAD	REFERENCIA PART N°	€
1/4"	7/16" 20h UNF	851390704	
3/8"	9/16" 18h UNF	851390906	
1/2"	3/4" 16h UNF	851391208	
3/4"	1"1/16 12h UN	851391712	
1"	1"5/16 12h UN	851392116	

## Conexiones Compactas PTFE Corrugado

Embouts pré-sertis pour PTFE convoluté

One piece fittings for convoluted PTFE

Raccordi compatti serie PTFE involuto

### Hembras giratorias rectas compactas rosca ORFS doble hexagonal

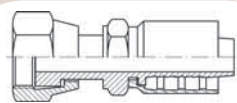

Femelle pré-sertie ORFS  
One piece ORFS female  
Femmina diritta compatta ORFS

DN	ROSCA THREAD	REFERENCIA PART N°	€
1/4"	9/16-18	859000904	
3/8"	11/16-16	859001106	
1/2"	13/16-16	859001308	
3/4"	1 3/16-12	859001912	
1"	1 7/16-12	859002316	

### Hembras giratorias 45° compactas rosca ORFS

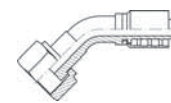

45° Femelle pré-sertie ORFS  
One piece 45° ORFS female  
Femmina 45° compatta ORFS

DN	ROSCA THREAD	REFERENCIA PART N°	€
1/4"	9/16-18	859080904	
3/8"	11/16-16	859081106	
1/2"	13/16-16	859081308	
3/4"	1 3/16-12	859081912	
1"	1 7/16-12	859082316	

### Hembras giratorias 90° compactas rosca ORFS



90° Femelle pré-sertie ORFS  
One piece 90° ORFS female  
Femmina 90° compatta ORFS

DN	ROSCA THREAD	REFERENCIA PART N°	€
1/4"	9/16-18	859070904	
3/8"	11/16-16	859071106	
1/2"	13/16-16	859071308	
3/4"	1 3/16-12	859071912	
1"	1 7/16-12	859072316	

### Machos compactos rosca ORFS

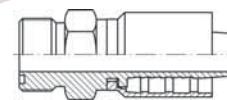

Mâle pré-serti ORFS  
One piece ORFS male  
Maschio compatto ORFS

DN	ROSCA THREAD	REFERENCIA PART N°	€
1/4"	9/16-18	859120904	
3/8"	11/16-16	859121106	
1/2"	13/16-16	859121308	
3/4"	1 3/16-12	859121912	
1"	1 7/16-12	859122316	

## Conexiones Compactas PTFE Corrugado

Embouts pré-sertis pour PTFE convoluté  
One piece fittings for convoluted PTFE  
Raccordi compatti serie PTFE involuto

### Hembras giratorias rectas compactas rosca NPSM cono 60°

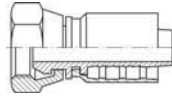

Femelle pré-sertie NPSM cono 60°  
One piece NPSM female 60° cone  
Femmina diritta compatta NPSM sede 60°

DN	ROSCA THREAD	REFERENCIA PART N°	€
1/4"	1/4" 18h NPSM	852610404	
3/8"	3/8" 18h NPSM	852610606	
1/2"	1/2" 14h NPSM	852610808	
3/4"	3/4" 14h NPSM	852611212	
1"	1" - 11 1/2 h NPSM	852611616	

### Machos compactos rosca cónica NPT

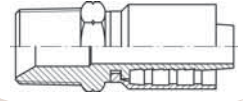

Mâle pré-serti NPT  
One piece NPT male  
Maschio compatto conico NPT

DN	ROSCA THREAD	REFERENCIA PART N°	€
1/4"	1/4" NPT	851610404	
3/8"	3/8" NPT	851610606	
1/2"	1/2" NPT	851610808	
3/4"	3/4" NPT	851611212	
1"	1" NPT	851611616	

### Hembras giratorias rectas compactas rosca NPSM cono 60° doble hexagonal

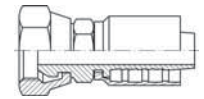

Femelle pré-sertie NPSM cono 60° double hexagonal  
One piece double hexagonal NPSM female 60° cone  
Femmina diritta compatta NPSM sede 60° doppio esagono

DN	ROSCA THREAD	REFERENCIA PART N°	€
1/4"	1/4" NPSM	853610404	
3/8"	3/8" 18h NPSM	853610606	
1/2"	1/2" 14h NPSM	853610808	
3/4"	3/4" NPSM	853611212	
1"	1" - 11 1/2 h NPSM	853611616	

### Hembras giratorias 90° compactas rosca NPSM cono 60°

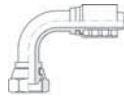

90° Femelle pré-sertie NPSM cono 60°  
One piece 90° NPSM female 60° cone  
Femmina 90° compatta NPSM sede 60°

DN	ROSCA THREAD	REFERENCIA PART N°	€
1/4"	1/4" 18h NPSM	852620404	
3/8"	3/8" 18h NPSM	852620606	
1/2"	1/2" 14h NPSM	852620808	
3/4"	3/4" 14h NPSM	852621212	
1"	1" - 11 1/2 h NPSM	852621616	

### Hembras giratorias 45° compactas rosca NPSM cono 60°

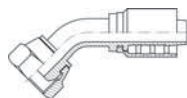

45° Femelle pré-sertie NPSM cono 60°  
One piece 45° NPSM female 60° cone  
Femmina 45° compatta NPSM sede 60°

DN	ROSCA THREAD	REFERENCIA PART N°	€
1/4"	1/4" 18h NPSM	852630404	
3/8"	3/8" 18h NPSM	852630606	
1/2"	1/2" 14h NPSM	852630808	
3/4"	3/4" 14h NPSM	852631212	
1"	1" - 11 1/2 h NPSM	852631616	

## Conexiones Compactas PTFE Corrugado

Embouts pré-sertis pour PTFE convoluté

One piece fittings for convoluted PTFE

Raccordi compatti serie PTFE involuto

### Hembras giratorias rectas compactas rosca Métrica cono 24° - DKO

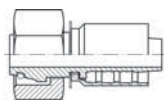

Femelle pré-sertie Métrique cone 24°

One piece Metric female 24° cone

Femmina diritta compatta Metrica sede 24°

DN	TUBO PIPE	SERIE	ROSCA THREAD	REFERENCIA PART N°	€
1/4"	8	L	M14x1.5	85804140804	
3/8"	12	L	M18x1.5	85804181206	
1/2"	15	L	M22x1.5	85804221508	
3/4"	22	L	M30x2	85804302212	
1"	28	L	M36x2	85804362816	
1/4"	8	S	M16x1.5	85804160804	
3/8"	12	S	M20x1.5	85804201206	
1/2"	16	S	M24x1.5	85804241608	
3/4"	25	S	M36x2	85804362512	
1"	30	S	M42x2	85804423016	

### Hembras giratorias 45° compactas rosca Métrica cono 24° - DKO 45°

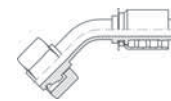

45° Femelle pré-sertie Métrique cone 24°

One piece 45° Metric female 24° cone

Femmina 45° compatta Metrica sede 24°

DN	TUBO PIPE	SERIE	ROSCA THREAD	REFERENCIA PART N°	€
1/4"	8	L	M14x1.5	85306140804	
3/8"	12	L	M18x1.5	85306181206	
1/2"	15	L	M22x1.5	85306221508	
3/4"	22	L	M30x2	85306302212	
1"	28	L	M36x2	85306362816	
1/4"	8	S	M10x1.5	85306160804	
3/8"	12	S	M20x1.5	85306201206	
1/2"	16	S	M24x1.5	85306241608	
3/4"	25	S	M36x2	85306362512	
1"	30	S	M42x2	85306423016	

### Hembras giratorias 90° compactas rosca Métrica cono 24° - DKO 90°

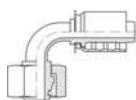

90° Femelle pré-sertie Métrique cone 24°

One piece 90° Metric female 24° cone

Femmina 90° compatta Metrica sede 24°

DN	TUBO PIPE	SERIE	ROSCA THREAD	REFERENCIA PART N°	€
1/4"	8	L	M14x1.5	85305140804	
3/8"	12	L	M18x1.5	85305181206	
1/2"	15	L	M22x1.5	85305221508	
3/4"	22	L	M30x2	85305302212	
1"	28	L	M36x2	85305362816	
1/4"	8	S	M16x1.5	85305160804	
3/8"	12	S	M20x1.5	85305201206	
1/2"	16	S	M24x1.5	85305241608	
3/4"	25	S	M36x2	85305362512	
1"	30	S	M42x2	85305423016	

### Machos compactos rosca Métrica cono 24°

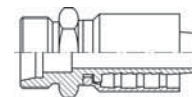

Mâle pré-serti Métrique cone 24°

One piece Metric male 24° cone

Maschio compatto Metrico sede 24°

DN	TUBO PIPE	SERIE	ROSCA THREAD	REFERENCIA PART N°	€
1/4"	8	L	M14x1.5	85203140804	
3/8"	12	L	M18x1.5	85203181206	
1/2"	15	L	M22x1.5	85203221508	
3/4"	22	L	M30x2	85203302212	
1"	28	L	M36x2	85203362816	
1/4"	8	S	M16x1.5	85203160804	
3/8"	12	S	M20x1.5	85203201206	
1/2"	16	S	M24x1.5	85203241608	
3/4"	25	S	M36x2	85203362512	
1"	30	S	M42x2	85203423016	

## Conexiones Compactas PTFE Corrugado

Embouts pré-sertis pour PTFE convoluté  
One piece fittings for convoluted PTFE  
Raccordi compatti serie PTFE involuto

### Hembras giratorias rectas compactas rosca BPS cono 60°

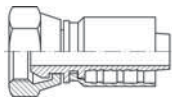

Femelle pré-sertie BSP cono 60°  
One piece BSP female 60° cone  
Femmina diritta compatta BSP sede 60°

DN	ROSCA THREAD	REFERENCIA PART N°	€
1/4"	1/4" BSP	851000404	
3/8"	3/8" BSP	851000606	
1/2"	1/2" BSP	851000808	
3/4"	3/4" BSP	851001212	
1"	1" BSP	851001616	

### Machos compactos rosca cilíndrica BSP cono 60°

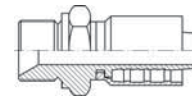

Mâle pré-serti BSP cono 60°  
One piece BSP male 60° cone  
Maschio compatto cilindrico BSP sede 60°

DN	ROSCA THREAD	REFERENCIA PART N°	€
1/4"	1/4" BSP	851120404	
3/8"	3/8" BSP	851120606	
1/2"	1/2" BSP	851120808	
3/4"	3/4" BSP	851121212	
1"	1" BSP	851121616	

### Hembras giratorias rectas compactas rosca BPS cono 60° doble hexagonal

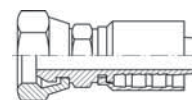

Femelle pré-sertie BSP cono 60° double hexagonal  
One piece double hexagonal BSP female 60° cone  
Femmina diritta compatta BSP sede 60° doppio esagono

DN	ROSCA THREAD	REFERENCIA PART N°	€
1/4"	1/4" BSP	854000404	
3/8"	3/8" BSP	854000606	
1/2"	1/2" BSP	854000808	
3/4"	3/4" BSP	854001212	
1"	1" BSP	854001616	

### Hembras giratorias 90° compactas rosca BPS cono 60°

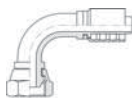

90° Femelle pré-sertie BSP cono 60°  
One piece 90° BSP female 60° cone  
Femmina 90° compatta BSP sede 60°

DN	ROSCA THREAD	REFERENCIA PART N°	€
1/4"	1/4" BSP	851070404	
3/8"	3/8" BSP	851070606	
1/2"	1/2" BSP	851070808	
3/4"	3/4" BSP	851071212	
1"	1" BSP	851071616	

### Hembras giratorias 45° compactas rosca BPS cono 60°

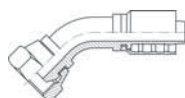

45° Femelle pré-sertie BSP cono 60°  
One piece 45° BSP female 60° cone  
Femmina 45° compatta BSP sede 60°

DN	ROSCA THREAD	REFERENCIA PART N°	€
1/4"	1/4" BSP	851080404	
3/8"	3/8" BSP	851080606	
1/2"	1/2" BSP	851080808	
3/4"	3/4" BSP	851081212	
1"	1" BSP	851081616	



## Conexiones Compactas Serie BW R12/4SP/4SH

Embouts pré-sertis R12/4SP/4SH Série BW  
One piece fittings BW Series R12/4SP/4SH  
Raccordi Compatti R12/4SP/4SH Serie BW

### Hembras giratorias rectas compactas JIC 37° doble hexagonal

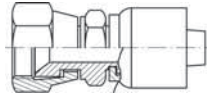

Femelle pré-sertie JIC 37° double hexagonal  
One piece double hexagonal JIC 37° Swivel female  
Femmina diritta compatta JIC 37° doppio esagono

DN	ROSCA THREAD	REFERENCIA PART N°	€
3/4"	1"1/16 12h UN	Z682421712	
1"	1"5/16 12h UN	Z682422116	
1"1/4	1"5/8 12h UN	Z682422620	
1"1/2	1"7/8 12h UN	Z682423024	
2"	2"1/2 12h UN	Z682424032	

### Hembras giratorias 90° compactas rosca JIC 37°

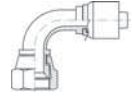

Coude 90° femelle pré-sertie JIC 37°  
One piece JIC 37° 90° swivel female  
Femmina gir. compatta 90° JIC 37°

DN	ROSCA THREAD	REFERENCIA PART N°	€
3/4"	1"1/16 12h UN	Z681381712	
1"	1"5/16 12h UN	Z681382116	
1"1/4	1"5/8 12h UN	Z681382620	
1"1/2	1"7/8 12h UN	Z681383024	
2"	2"1/2 12h UN	Z681384032	

### Machos compactos rosca JIC 37°

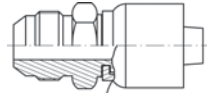

Mâle pré-serti JIC 37°  
One piece JIC 37° male  
Maschio compatto JIC 37°

DN	ROSCA THREAD	REFERENCIA PART N°	€
3/4"	1"1/16 12h UN	Z681401712	
1"	1"5/16 12h UN	Z681402116	
1"1/4	1"5/8 12h UN	Z681402620	
1"1/2	1"7/8 12h UN	Z681403024	
2"	2"1/2 12h UN	Z681404032	

### Hembras giratorias 45° compactas rosca JIC 37°



Coude 45° femelle pré-sertie JIC 37°  
One piece JIC 37° 45° swivel female  
Femmina gir. compatta 45° JIC 37°

DN	ROSCA THREAD	REFERENCIA PART N°	€
3/4"	1"1/16 12h UN	Z681391712	
1"	1"5/16 12h UN	Z681392116	
1"1/4	1"5/8 12h UN	Z681392620	
1"1/2	1"7/8 12h UN	Z681393024	
2"	2"1/2 12h UN	Z681394032	

### Hembras giratorias rectas compactas ORFS doble hexagonal

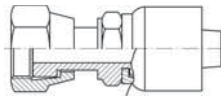

Femelle pré-sertie droite ORFS double hexagonale  
One piece ORFS Swivel female straight double hexagonal  
Femmina diritta compatta ORFS doppio esagono

DN	ROSCA THREAD	REFERENCIA PART N°	€
3/4"	1 3/16-12	Z689011912	
1"	1 7/16-12	Z689012316	
1"1/4	1 11/16-12	Z689012720	
1"1/2	2-12	Z689013224	

### Machos compactos ORFS

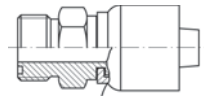

Mâle pré-serti ORFS  
One piece ORFS Male  
Maschio compatto ORFS

DN	ROSCA THREAD	REFERENCIA PART N°	€
3/4"	1 3/16-12	Z689121912	
1"	1 7/16-12	Z689122316	
1"1/4	1 11/16-12	Z689122720	
1"1/2	2-12	Z689123224	

### Hembras giratorias 90° compactas ORFS



Coude 90° femelle pré-sertie ORFS  
One piece 90° ORFS Swivel female  
Femmina 90° compatta ORFS

DN	ROSCA THREAD	REFERENCIA PART N°	€
3/4"	1 3/16-12	Z689081912	
1"	1 7/16-12	Z689082316	
1"1/4	1 11/16-12	Z689082720	
1"1/2	2-12	Z689083224	

### Hembras giratorias 45° compactas ORFS

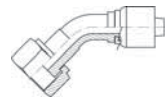

Coude 45° femelle pré-sertie ORFS  
One piece 45° ORFS Swivel female  
Femmina 45° compatta ORFS

DN	ROSCA THREAD	REFERENCIA PART N°	€
3/4"	1 3/16-12	Z689081912	
1"	1 7/16-12	Z689082316	
1"1/4	1 11/16-12	Z689082720	
1"1/2	2-12	Z689083224	

## Conexiones Compactas Serie BW R12/4SP/4SH

Embouts pré-sertis R12/4SP/4SH Série BW  
One piece fittings BW Series R12/4SP/4SH  
Raccordi Compatti R12/4SP/4SH Serie BW

### Hembras giratorias rectas compactas NPSM cono 60° doble hexagonal

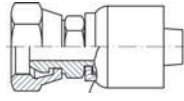

Femelle pré-sertie NPSM cone 60° double hexagonal  
One piece double hexagonal NPSM female 60° cone  
Femmina diritta compatta NPSM sede 60° doppio esagono

DN	ROSCA THREAD	REFERENCIA PART N°	€
3/4"	3/4" NPSM	Z683611212	
1"	1" NPSM	Z683611616	
1"1/4	1"1/4 NPSM	Z683612020	
1"1/2	1"1/2 NPSM	Z683612424	
2"	2" NPT	Z683613232	

### Machos cónicos compactos 60° NPT

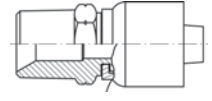

Mâle pré-serti conique NPT cone 60°  
One piece NPT Male 60° cone  
Maschio compatto conico NPTsede 60°

DN	ROSCA THREAD	REFERENCIA PART N°	€
3/4"	3/4" NPT	Z681611212	
1"	1" NPT	Z681611616	
1"1/4	1"1/4 NPT	Z681612020	
1"1/2	1"1/2 NPT	Z681612424	
2"	2" NPT	Z681613232	

### Bridas rectas compactas SAE 3000 PSI

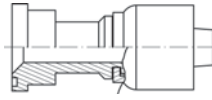

Bride SAE droite pré-sertie série 3000 PSI  
One piece 3000 PSI SAE Straight Flange / Code 61  
Flangia diritta compatta SAE 3000

DN	Ø	REFERENCIA PART N°	€
3/4"	38.1	Z681821212	
1"	44.5	Z681821616	
1"1/4	50.8	Z681822020	
1"1/2	60.3	Z681822424	
2"	71.4	Z681823232	

### Bridas rectas compactas SAE 6000 PSI

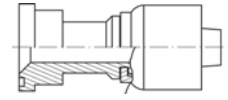

Bride SAE droite pré-sertie série 6000 PSI  
One piece 6000 PSI SAE Straight Flange / Code 62  
Flangia diritta compatta SAE 6000

DN	Ø	REFERENCIA PART N°	€
3/4"	41.3	Z682821212	
1"	47.6	Z682821616	
1"1/4	54	Z682822020	
1"1/2	63.5	Z682822424	
2"	79.4	Z682823232	

### Bridas 90° compactas SAE 3000 PSI

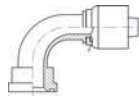

Bride SAE coude 90° pré-sertie série 3000 PSI  
One piece 3000 PSI SAE 90° Flange / Code 61  
Flangia 90° compatta SAE 3000

DN	Ø	REFERENCIA PART N°	€
3/4"	38.1	Z681831212	
1"	44.5	Z681831616	
1"1/4	50.8	Z681832020	
1" 1/2	60.3	Z681832424	
2"	71.4	Z681833232	

### Bridas 90° compactas SAE 6000 PSI

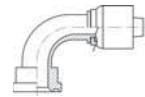

Bride SAE coude 90° pré-sertie série 6000 PSI  
One piece 6000 PSI SAE 90° Flange / Code 62  
Flangia 90° compatta SAE 6000

DN	Ø	REFERENCIA PART N°	€
3/4"	41.3	Z682831212	
1"	47.6	Z682831616	
1"1/4	54	Z682832020	
1"1/2	63.5	Z682832424	
2"	79.4	Z682833232	

### Bridas 45° compactas SAE 3000 PSI

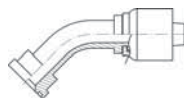

Bride SAE coude 45° pré-sertie série 3000 PSI  
One piece 3000 PSI SAE 45° Flange / Code 61  
Flangia 45° compatta SAE 3000

DN	Ø	REFERENCIA PART N°	€
3/4"	38.1	Z681841212	
1"	44.5	Z681841616	
1"1/4	50.8	Z681842020	
1" 1/2	60.3	Z681842424	
2"	71.4	Z681843232	

### Bridas 45° compactas SAE 6000 PSI

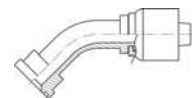

Bride SAE coude 45° pré-sertie série 6000 PSI  
One piece 6000 PSI SAE 45° Flange / Code 62  
Flangia 45° compatta SAE 6000

DN	Ø	REFERENCIA PART N°	€
3/4"	41.3	Z682841212	
1"	47.6	Z682841616	
1"1/4	54	Z682842020	
1"1/2	63.5	Z682842424	
2"	79.4	Z682843232	

## Conexiones Compactas Serie BW R12/4SP/4SH

Embouts pré-sertis R12/4SP/4SH Série BW  
One piece fittings BW Series R12/4SP/4SH  
Raccordi Compatti R12/4SP/4SH Serie BW

### Hembras giratorias rectas compactas rosca Métrica cono 24° con junta tórica

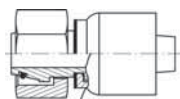

Femelle pré-sertie Métrique 24° avec o'ring  
One piece Metric swivel female 24° seat with o'ring  
Femmina compatta Metrica sede 24° con o'ring

DN	TUBO PIPE	SERIE	ROSCA THREAD	REFERENCIA PART N°	€
3/4"	20	S	M30x2	Z68204302012	
3/4"	25	S	M36x2	Z68204362512	
1"	30	S	M42x2	Z68204423016	
1"1/4	38	S	M52x2	Z68204523820	

### Hembras giratorias 90° compactas métricas cono 24° con junta tórica



Coude 90° femelle pré-sertie Métrique 24° avec o'ring  
One piece 90° Metric swivel female 24° seat with o'ring  
Femmina compatta Metrica 90° sede 24° con o'ring

DN	TUBO PIPE	SERIE	ROSCA THREAD	REFERENCIA PART N°	€
3/4"	20	S	M30x2	Z68205302012	
3/4"	25	S	M36x2	Z68205362512	
1"	30	S	M42x2	Z68205423016	
1"1/4	38	S	M52x2	Z68205523820	

### Machos compactos Métricos cono 24°

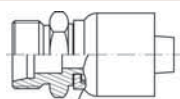

Mâle pré-serti Métrique cone 24°  
One piece Metric male stud 24° cone  
Maschio compatto Metrico sede 24° con o'ring

DN	TUBO PIPE	SERIE	ROSCA THREAD	REFERENCIA PART N°	€
3/4"	20	S	M30x2	Z68203302012	
3/4"	25	S	M36x2	Z68203362512	
1"	30	S	M42x2	Z68203423016	
1"1/4	38	S	M52x2	Z68203523820	

### Hembras giratorias 45° compactas Métricas cono 24° con junta tórica

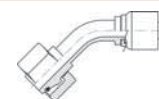

Coude 45° femelle pré-sertie Métrique 24° avec o'ring  
One piece 45° Metric swivel female 24° seat with o'ring  
Femmina compatta Metrica 45° sede 24°

DN	TUBO PIPE	SERIE	ROSCA THREAD	REFERENCIA PART N°	€
3/4"	20	S	M30x2	Z68206302012	
3/4"	25	S	M36x2	Z68206362512	
1"	30	S	M42x2	Z68206423016	
1"1/4	38	S	M52x2	Z68206523820	

### Hembras giratorias rectas compactas BSP 60° doble hexagonal

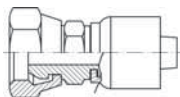

Femelle pré-sertie BSP cone 60° double hexagonal  
One piece double hexagonal BSP Swivel female cone 60°  
Femmina diritta compatta BSP sede 60° doppio esagono

DN	ROSCA THREAD	REFERENCIA PART N°	€
3/4"	3/4" BSP	Z684001212	
1"	1" BSP	Z684001616	
1"1/4	1"1/4 BSP	Z684002020	
1"1/2	1"1/2 BSP	Z684002424	
2"	2" BSP	Z684003232	

### Hembras giratorias 45° compactas BSP 60°

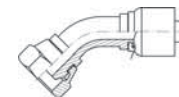

Coude 45° femelle pré-sertie BSP 60°  
One piece BSP Swivel female 45° 60° cone  
Femmina 45° compatta BSP sede 60°

DN	ROSCA THREAD	REFERENCIA PART N°	€
3/4"	3/4" BSP	Z681081212	
1"	1" BSP	Z681081616	
1"1/4	1"1/4 BSP	Z681082020	
1"1/2	1"1/2 BSP	Z681082424	
2"	2" BSP	Z681083232	

### Hembras giratorias 90° compactas BSP 60°



Coude 90° femelle pré-sertie BSP 60°  
One piece BSP Swivel female 90° 60° cone  
Femmina 90° compatta BSP sede 60°

DN	ROSCA THREAD	REFERENCIA PART N°	€
3/4"	3/4" BSP	Z681071212	
1"	1" BSP	Z681071616	
1"1/4	1"1/4 BSP	Z681072020	
1"1/2	1"1/2 BSP	Z681072424	
2"	2" BSP	Z681073232	

### Machos cilíndricos compactos BSP 60°



Mâle pré-serti gaz cylindrique BSP 60°  
One piece BSP Male 60° cone with o'ring  
Maschio compatto BSP cilindrico sede 60°

DN	ROSCA THREAD	REFERENCIA PART N°	€
3/4"	3/4" BSP	Z681121212	
1"	1" BSP	Z681121616	
1"1/4	1"1/4 BSP	Z681122020	
1"1/2	1"1/2 BSP	Z681122424	
2"	2" BSP	Z681123232	

## Casquillos para Conexiones Compactas

Jupes pour embouts pré-sertis  
 Ferrules for one piece fittings  
 Boccole per raccordi compatti

Crimp fittings for hoses

Pipe fittings DIN 2353

Flare fittings JIC  
SAE flanges

Adaptors

Welding fittings

Industrial fittings

Several items

### Casquillos R1AT/ R2AT/1SN/2SN /R16/2SC para conexiones compactas serie 43

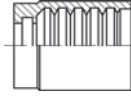

Jupes R1AT/R2AT/1SN/2SN/R16/2SC pour embouts pré-sertis série 43  
 Ferrules R1AT/R2AT/1SN/2SN/R16/2SC for one piece fittings 43 series  
 Boccole a pressione R1AT/R2AT/1SN/2SN/R16/2SN per raccordi compatti serie 43

DN	REFERENCIA PART N°	€
1/4"	ZPFC221200400	
5/16"	ZPFC221200500	
3/8"	ZPFC221200600	
1/2"	ZPFC221200800	
5/8"	ZPFC221201000	
3/4"	ZPFC221201200	
1"	ZPFC221201600	
1"1/4	ZPFC221202000	
1"1/2	ZPFC221202400	
2"	ZPFC221203200	

### Casquillos PTFE Corrugado para conexiones compactas



Jupes PTFE Convoluté pour embouts pre-sertis  
 Ferrules convoluted PTFE for one piece fittings  
 Boccole a pressione PTFE corrugato per raccordi compatti

DN	REFERENCIA PART N°	€
1/4"	880410400	
5/16"	880410500	
3/8"	880410600	
1/2"	880410800	
5/8"	880411000	
3/4"	880411200	
1"	880411600	

### Casquillos R7, R8 y elastómero malla metálica para conexiones compactas

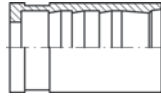

Jupes R7, R8 et elastomère tresse métallique pour embouts pre-sertis  
 Ferrules R7, R8 and braid of steel wire for one piece fittings  
 Boccole a pressione R7, R8 per raccordi compatti

DN	REFERENCIA PART N°	€
1/4"	880120400	
5/16"	880120500	
3/8"	880120600	
1/2"	880120800	
3/4"	880121200	
1"	880121600	

### Casquillos R12/4SP/4SH para conexiones compactas serie BW

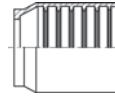

Jupes R12/4SP/4SH pour embouts pré-sertis série BW  
 Ferrules R12/4SP/4SH for one piece fittings BW series  
 Boccole a pressione per R12/4SP/4SH per raccordi compatti serie BW

DN	REFERENCIA PART N°	€
3/4"	ZAC680101200	
1"	ZAC680101600	
1"1/4	ZAC680102000	
1"1/2	ZAC680102400	
2"	ZAC680103200	

### Casquillos PTFE Liso para conexiones compactas

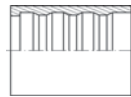

Jupes PTFE Lisse pour embouts pre-sertis  
 Ferrules smooth PTFE for one piece fittings  
 Boccole a pressione PTFE liscio per raccordi compatti

DN	REFERENCIA PART N°	€
1/4"	880400400	
5/16"	880400500	
3/8"	880400600	
1/2"	880400800	
5/8"	880401000	
3/4"	880401200	
1"	880401600	

### Casquillos R2A-2ST/4SP DIN 20023 para conexiones compactas



Jupes R2A-2ST/4SP DIN 20023 pour embouts pre-sertis  
 Ferrules R2A-2ST/4SP DIN 20023 for one piece fittings  
 Boccole a pressione per R2A-2ST/4SP DIN 20023 per raccordi compatti

DN	REFERENCIA PART N°	€
1/4"	ZPFC122400400	
3/8"	ZPFC122400600	
1/2"	ZPFC122400800	
3/4"	ZPFC122401200	
1"	ZPFC122401600	

## Conexiones compactas

Embouts pré-sertis | One piece fittings | Raccordi compatti

Se pueden montar en todas las conexiones de la serie STD / On peut sertir ces jupes avec tous les embouts STD / These ferrules are suitable to be crimped with all the STD fittings / Si possono montare in tutte le connessioni della serie STD.

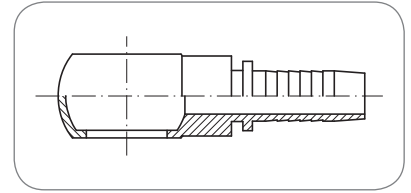
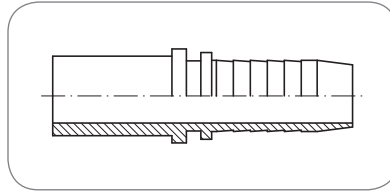
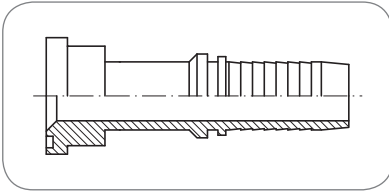

Para consultar indicar: "Compacto" + ref. conexión + ref. casquillo | Pour consulter, il faut indiquer: "Pré-serti" + Réf. Embout + Réf. Jupe | To request them, you should indicate: "One piece" + Fitting part nr + Ferrule part nr | Per ricuidere, indicare: "Compatto" + Codice Raccordo + Codice Boccola

Ejemplo: SERIE STANDARD

Compacto 841821212 + ZPFC122401200  
Pré-serti 841821212 + ZPFC122401200  
One piece 841821212 + ZPFC122401200  
Compatto 841821212 + ZPFC12240120

Ejemplo: PTFE LISO

Compacto 841111616 + 880401600  
Pré-serti 841111616 + 880401600  
One piece 841111616 + 880401600  
Compatto 841111616 + 880401600

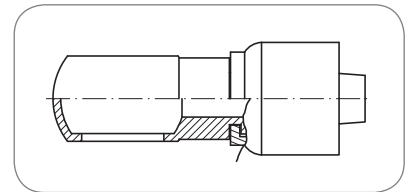
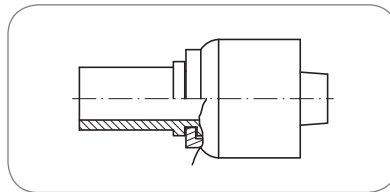
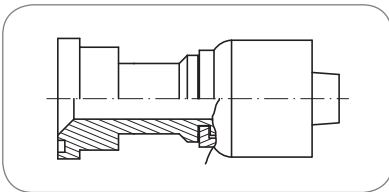

## Conexiones Reusables

Embouts série récupérable  
Reusable series  
Serie Recuperabile

Crimp fittings for hoses

Pipe fittings DIN 2353

Flare fittings JIC  
SAE flanges

Adaptors

Welding fittings

Industrial fittings

Several items

### Casquillos reusables para manguera R1A pelar

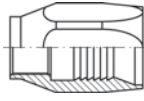

Jupes récupérables R1A avec dénudage  
Reusable ferrules R1A skive  
Boccola recuperabile R1A con pelatura

DN	REFERENCIA PART N°	€
1/4"	Z1G-4 R1 INOX	
5/16"	Z1G-5 R1 INOX	
3/8"	Z1G-6 R1 INOX	
1/2"	Z1G-8 R1 INOX	
5/8"	Z1G-10 R1 INOX	
3/4"	Z1G-12 R1 INOX	
1"	Z1G-16 R1 INOX	

\*Hasta fin de existencias/\*\*Jusqu'à la fin du stock/\*\*Until end of stock/\*\*Fino ad esaurimento scorta

### Casquillos reusables para manguera R1T no pelar

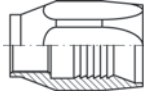

Jupes récupérables R1T sans dénudage  
Reusable ferrules R1T non skive  
Boccola recuperabile per R1T senza pelatura

DN	REFERENCIA PART N°	€
1/4"	Z1G-4 R1T INOX	
5/16"	Z1G-5 R1T INOX	
3/8"	Z1G-6 R1T INOX	
1/2"	Z1G-8 R1T INOX	
3/4"	Z1G-12 R1T INOX	
1"	Z1G-16 R1T INOX	
1"1/4	Z1G-20 R1T INOX	

### Casquillos reusables para manguera R2A pelar

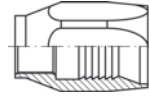

Jupes récupérables R2A avec dénudage  
Reusable ferrules R2A skive  
Boccola recuperabile per R2A con pelatura

DN	REFERENCIA PART N°	€
1/4"	Z1G-4 R2 INOX	
5/16"	Z1G-5 R2 INOX	
3/8"	Z1G-6 R2 INOX	
1/2"	Z1G-8 R2 INOX	
5/8"	Z1G-10 R2 INOX	
3/4"	Z1G-12 R2 INOX	
1"	Z1G-16 R2 INOX	
1"1/4	Z1G-20 R2 INOX	
1"1/2	Z1G-24 R2 INOX	

\*Hasta fin de existencias/\*\*Jusqu'à la fin du stock/\*\*Until end of stock/\*\*Fino ad esaurimento scorta

### Casquillos reusables para manguera R2AT no pelar

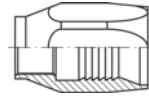

Jupes récupérables R2AT sans dénudage  
Reusable ferrules R2AT non skive  
Boccola recuperabile per R2AT senza pelatura

DN	REFERENCIA PART N°	€
1/4"	Z1G-4 R2T INOX	
3/8"	Z1G-6 R2T INOX	
1/2"	Z1G-8 R2T INOX	
3/4"	Z1G-12 R2T INOX	
1"	Z1G-16 R2T INOX	

### Hembras giratorias rectas reusables rosca BSP cono 60°

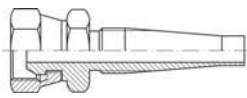

Femelle récupérable gaz cylindrique 60°  
Reusable BSP Swivel female 60° cone  
Femmina diritta BSP sede 60° recuperabile

DN	ROSCA THREAD	REFERENCIA PART N°	€
1/4"	1/4" BSP	Z3G-4	
5/16"	3/8" BSP	Z3G-6-5	
3/8"	3/8" BSP	Z3G-6	
3/8"	1/2" BSP	Z3G-8-6	
1/2"	1/2" BSP	Z3G-8	
5/8"	1/2" BSP	Z3G-8-10	
3/4"	3/4" BSP	Z3G-12	
1"	1" BSP	Z3G-16	
1"1/4	1"1/4 BSP	Z3G-20	
1"1/2	1"1/2 BSP	Z3G-24	

### Hembras giratorias 90° reusables rosca BSP cono 60°



Coude 90° femelle récupérable gaz cylindrique BSP 60°  
Reusable BSP 90° Swept elbow 60° cone  
Femmina 90° BSP sede 60° recuperabile

DN	ROSCA THREAD	REFERENCIA PART N°	€
1/4"	1/4" BSP	Z90G-4	
3/8"	3/8" BSP	Z90G-6	
3/8"	1/2" BSP	Z90G-8-6	
1/2"	1/2" BSP	Z90G-8	
3/4"	3/4" BSP	Z90G-12	
1"	1" BSP	Z90G-16	

## Conexiones Reusables

Embouts série récupérable  
Reusable series  
Serie Recuperabile

### Machos reusables rosca cilíndrica BSP cono 60°

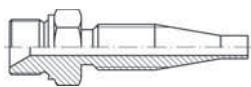

Mâle récupérable gaz cylindrique BSP 60°  
Reusable BSP Male parallel 60° cone  
Maschio BSP cilindrico sede 60° recuperabile

DN	ROSCA THREAD	REFERENCIA PART N°	€
1/4"	1/4" BSP	<b>Z2G-4</b>	
3/8"	3/8" BSP	<b>Z2G-6</b>	
5/16"	3/8" BSP	<b>Z2G-6-5</b>	
1/2"	1/2" BSP	<b>Z2G-8</b>	
3/8"	1/2" BSP	<b>Z2G-8-6</b>	
3/4"	3/4" BSP	<b>Z2G-12</b>	
1"	1" BSP	<b>Z2G-16</b>	
1"1/4	1"1/4 BSP	<b>Z2G-20</b>	

### Espigas lisas Métricas reusables

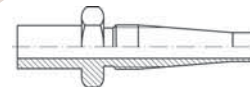

Embout lisse récupérable Métrique  
Reusable Metric standpipe  
Estremitá tubolare recuperabile

DN	TUBO PIPE	REFERENCIA PART N°	€
1/4"	6	<b>ZE-6-4</b>	
1/4"	8	<b>ZE-8-4</b>	
3/8"	8	<b>ZE-8-6</b>	
1/4"	10	<b>ZE-10-4</b>	
5/16"	10	<b>ZE-10-5</b>	
3/8"	10	<b>ZE-10-6</b>	
5/16"	12	<b>ZE-12-5</b>	
3/8"	12	<b>ZE-12-6</b>	
3/8"	15	<b>ZE-15-6</b>	
1/2"	15	<b>ZE-15-8</b>	
1/2"	16	<b>ZE-16-8</b>	
3/4"	22	<b>ZE-22-12</b>	
3/4"	25	<b>ZE-25-12</b>	
1"	25	<b>ZE-25-16</b>	
1"	28	<b>ZE-28-16</b>	
1"	30	<b>ZE-30-16</b>	

- **Hembra giratorias rectas reusables rosca JIC cono 37°**  
Femelle récupérable JIC cone 37° | Reusable JIC Swivel female 37° cone | Fémina JIC sede 37° recuperabile

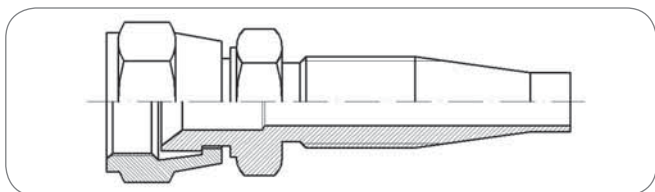

ref: Z3J...

- **Macho reusable rosca JIC cono 37°**  
Mâle récupérable JIC cone 37° | Reusable JIC Male 37° cone | Maschio JIC sede 37° recuperabile

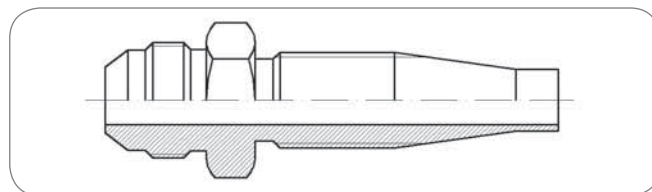

ref: Z2J...

- **Hembra giratorias rectas reusables rosca Métrica cono 24°**  
Femelle récupérable Métrique cone 24° | Reusable Metric Swivel female 24° cone | Fémina Metrica sede 24° recuperabile

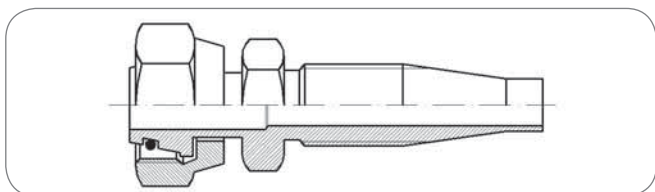

ref: Z3M...

- **Macho reusable rosca Métrica cono 24°**  
Mâle récupérable Métrique cone 24° | Reusable Metric Male 24° cone | Maschio Metrica sede 24° recuperabile

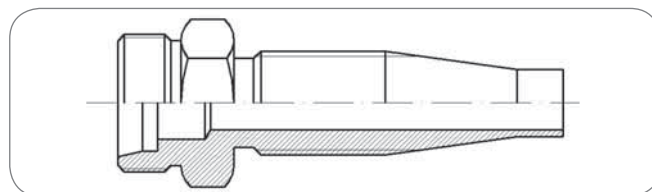

ref: Z2M...

## Conexiones Push-On

Embouts Push-On  
Push-On Fittings  
Raccordi Serie Push-On

### Hembras giratorias rectas rosca BSP cono 60°

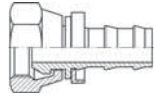

Femelle tournante BSP cone 60°  
BSP Swivel female 60° cone  
Femmina diritta BSP sede 60°

DN	ROSCA THREAD	REFERENCIA PART N°	€
1/4"	1/4" BSP	891000404	
3/8"	3/8" BSP	891000606	
1/2"	1/2" BSP	891000808	
5/8"	5/8" BSP	891001010	
3/4"	3/4" BSP	891001212	
1"	1" BSP	891001616	

### Machos rosca cilíndrica BSP cono 60°

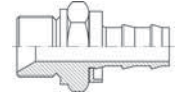

Mâle fixe BSP cone 60°  
BSP Male 60° cone  
Maschio BSP cilindrico sede 60°

DN	ROSCA THREAD	REFERENCIA PART N°	€
1/4"	1/4" BSP	891120404	
3/8"	3/8" BSP	891120606	
1/2"	1/2" BSP	891120808	
3/4"	1/2" BSP	891120812	
5/8"	5/8" BSP	891121010	
3/4"	3/4" BSP	891121212	
1"	1" BSP	891121616	

### Hembras giratorias rectas JIC 37°

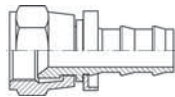

Femelle tournante JIC 37°  
37° JIC Swivel female  
Femmina diritta JIC sede 37°

DN	ROSCA THREAD	REFERENCIA PART N°	€
1/4"	7/16" 20h UNF	891420704	
3/8"	9/16" 18h UNF	891420906	
1/2"	3/4" 16h UNF	891421208	
5/8"	7/8" 14h UNF	891421410	
3/4"	1"1/16 12h UN	891421712	
1"	1"5/16 12h UN	891422116	

### Machos rosca JIC cono 37°

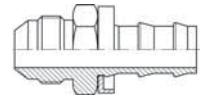

Mâle fixe JIC 37°  
37° JIC Male  
Maschio JIC sede 37°

DN	ROSCA THREAD	REFERENCIA PART N°	€
1/4"	7/16" 20h UNF	891400704	
3/8"	9/16" 18h UNF	891400906	
1/2"	3/4" 16h UNF	891401208	
5/8"	7/8" 14h UNF	891401410	
3/4"	1"1/16 12h UN	891401712	
1"	1"5/16 12h UN	891402116	

### Machos rosca cónica NPT

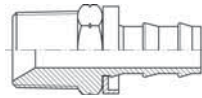

Mâle gaz conique NPT (BRIGGS)  
NPT Male thread  
Maschio NPT conico

DN	ROSCA THREAD	REFERENCIA PART N°	€
1/4"	1/4" NPT	891610404	
3/8"	3/8" NPT	891610606	
1/2"	1/2" NPT	891610808	
3/4"	3/4" NPT	891611212	
1"	1" NPT	891611616	



## Conexiones Push-On

Embouts Push-On  
Push-On Fittings  
Raccordi Serie Push-On

### Hembra giratoria recta rosca Métrica cono 24°

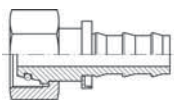

Femelle Métrique avec o'ring cône 24°  
Metric female swivel with o'ring 24° cone  
Femmina Metrica sede 24° con o'ring

DN	TUBO PIPE	SERIE	ROSCA THREAD	REFERENCIA PART N°	€
1/4"	8	L	M14x1.5	<b>89804140804</b>	
1/4"	10	L	M16x1.5	<b>89804161004</b>	
3/8"	12	L	M18x1.5	<b>89804181206</b>	
1/2"	15	L	M22x1.5	<b>89804221508</b>	
3/4"	22	L	M30x2	<b>89804302212</b>	

### Machos rosca métrica cono 24°

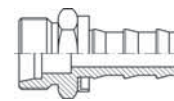

Mâle Métrique cône 24°  
Metric stud 24° cone  
Maschio Metrico sede 24°

DN	TUBO PIPE	SERIE	ROSCA THREAD	REFERENCIA PART N°	€
1/4"	8	L	M14x1.5	<b>89203140804</b>	
1/4"	10	L	M16x1.5	<b>89203161004</b>	
3/8"	12	L	M18x1.5	<b>89203181206</b>	
1/2"	15	L	M22x1.5	<b>89203221508</b>	
3/4"	22	L	M30x2	<b>89203302212</b>	

## Conexiones Alta Presión (700 bar)

Embouts haute pression 700 bar  
High pressure 700 bar fittings  
Raccordi Altissima pressione (700 bar)

### Casquillos para alta presión (700bar)

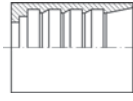

Jupes à sertir thermoplastique 700 bar

Ferrules for thermoplastic hose 700 bar

Boccole per tubo termoplastico 700 bar

DN	REFERENCIA PART N°	€
1/4"	Z710120400	
3/8"	Z710120600	
1/2"	Z710120800	

### Hembra giratoria BSP cono 60° (700bar)

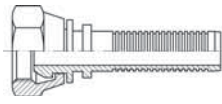

Embout 700 bar femelle tournante gaz cyl BSP 60°

BSP Swivel female 60° cone 700 bar

Femmina diritta BSP sede 60° 700 bar

DN	ROSCA THREAD	REFERENCIA PART N°	€
1/4"	1/4" BSP	Z741000404	
3/8"	3/8" BSP	Z741000606	
1/2"	1/2" BSP	Z741000808	

### Macho BSP cono 60° (700bar)

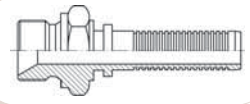

Embout 700 bar mâle fixe gaz cyl BSP 60°

BSP Male parallel 60° cone 700 bar

Maschio cilindrico BSP sede 60° 700 bar

DN	ROSCA THREAD	REFERENCIA PART N°	€
1/4"	1/4" BSP	Z741120404	
3/8"	3/8" BSP	Z741120606	
1/2"	1/2" BSP	Z741120808	

### Hembra giratoria NPSM cono 60° (700bar)

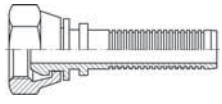

Embout 700 bar femelle tournante NPSM 60°

NPSM Swivel female 60° cone 700 bar

Femmina diritta NPSM sede 60° 700 bar

DN	ROSCA THREAD	REFERENCIA PART N°	€
1/4"	1/4" 18h NPSM	Z742610404	
3/8"	3/8" 18h NPSM	Z742610606	
1/2"	1/2" 14h NPSM	Z742610808	

### Macho NPT cono 60° (700bar)

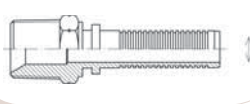

Embout 700 bar mâle fixe gaz conique NPT

NPT conic Male 60° cone 700 bar

Maschio conico NPT 700 bar

DN	ROSCA THREAD	REFERENCIA PART N°	€
1/4"	1/4" NPT	Z741610404	
1/4"	3/8" NPT	Z741610604	
3/8"	3/8" NPT	Z741610606	
1/2"	1/2" NPT	Z741610808	

### Hembra giratoria JIC 37° (700bar)

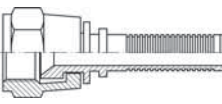

Embout 700 bar femelle tournante droit JIC 37°

JIC Swivel female 37° cone 700 bar

Femmina JIC 37° 700 bar

DN	ROSCA THREAD	REFERENCIA PART N°	€
1/4"	7/16" 20h UNF	Z741420704	
1/4"	9/16" 18h UNF	Z741420904	
3/8"	9/16" 18h UNF	Z741420906	
1/2"	3/4" 16h UNF	Z741421208	

### Macho JIC 37° (700bar)

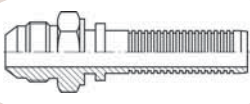

Embout 700 bar mâle fixe JIC 37°

JIC 37° Male thread 700 bar

Maschio JIC 37° 700 bar

DN	ROSCA THREAD	REFERENCIA PART N°	€
1/4"	7/16" 20h UNF	Z741400704	
3/8"	9/16" 18h UNF	Z741400906	
1/2"	3/4" 16h UNF	Z741401208	

## Conexiones Alta Presión (700 bar)

Embouts haute pression 700 bar

High pressure 700 bar fittings

Raccordi Altissima pressione (700 bar)

### Hembra giratoria Métrica 24° (700bar)

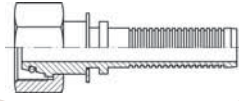

Embout 700 bar femelle tournante droit Métrique cone 24°

Metric Swivel female 24° cone 700 bar

Femmina diritta Metrica sede 24° 700 bar

DN	TUBO PIPE	SERIE	ROSCA THREAD	REFERENCIA PART N°	€
1/4"	8	S	M16x1.5	<b>Z74804160804</b>	
3/8"	12	S	M20x1.5	<b>Z74804201206</b>	
1/2"	16	S	M24x1.5	<b>Z74804241608</b>	

### Macho Métrico 24° (700bar)

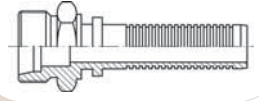

Embout 700 bar mâle fixe Métrique cone 24°

Metric Male 24° cone 700 bar

Maschio cilindrico Metrico sede 24° 700 bar

DN	TUBO PIPE	SERIE	ROSCA THREAD	REFERENCIA PART N°	€
1/4"	8	S	M16x1.5	<b>Z74203160804</b>	
3/8"	12	S	M20x1.5	<b>Z74203201206</b>	
1/2"	16	S	M24x1.5	<b>Z74203241608</b>	

## Conexiones Micro-hose

Embouts Minimes  
Micro-hose fittings  
Raccordi Micro-tubo

### Casquillos AISI-303

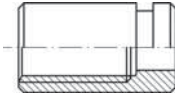

Jupes AISI-303  
Ferrules AISI -303  
Boccole AISI-303

DN	REFERENCIA PART N°	€
2	Z555010100	

### Espiga lisa Métrica

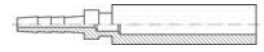

Embout lisse Métrique Minimes  
Metric standpipe Micro-hose  
Estremità tubolare Metrica

DN	TUBO PIPE	REFERENCIA PART N°	€
2	6	Z555070600	
2	8	Z555070800	

### Hembra asiento plano con junta manómetro

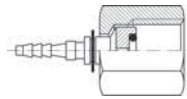

Embout femelle tournante fond plat + o'ring pour manomètre Minimes  
Swivel female flat seat with o'ring for manometer Micro-hose  
Femmina sede piana con o'ring per manometro

DN	ROSCA THREAD	REFERENCIA PART N°	€
2	1/4" BSP	Z555050404	
2	1/2" BSP	Z555050808	

### Macho de control



Embout mâle manomètre  
Straight Micro-hose check male  
Presa di pressione maschio

DN	REFERENCIA PART N°	€
2	Z555030325	

### Hembra giratoria de control

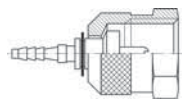

Embout femelle tournante de control Métrique Minimes  
Check Metric swivel female Micro-hose  
Presa di pressione femmina

DN	ROSCA THREAD	REFERENCIA PART N°	€
2	M16X2	Z555069523	

### Racores de control macho



Prises de pression mâle  
Male check couplings  
Mini-presa di controllo maschio

ROSCA THREAD	REFERENCIA PART N°	€
1/4" BSP M10x1	Z MPR 1/4 G Z MPR M10	

Toma de control M16x2//Prise de pression M16x2//Test coupling M16x2//Presa di pressione M16x2

### Hembra as. 60°

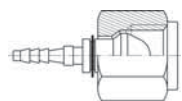

Embout femelle tournante gaz cyl BSP 60° Minimes  
Straight swivel female BSP 60° cone micro-hose  
Femmina girevole BSP

DN	ROSCA THREAD	REFERENCIA PART N°	€
2	1/4" BSP	Z555040404	

### Racores de control TLM



Prises de pression TLM  
TLM Check couplings  
Mini-presa di controllo TLM

TUBO PIPE	SERIE	ROSCA THREAD	REFERENCIA PART N°	€
6	L	M12x1.5	Z MPR TLM 6L	
8	L	M14x1.5	Z MPR TLM 8L	
10	L	M16x1.5	Z MPR TLM 10L	
12	L	M18x1.5	Z MPR TLM 12L	
6	S	M14x1.5	Z MPR TLM 6S	
8	S	M16x1.5	Z MPR TLM 8S	
10	S	M18x1.5	Z MPR TLM 10S	
12	S	M20x1.5	Z MPR TLM 12S	

Toma de control M16x2//Prise de pression M16x2//Test coupling M16x2//Presa di pressione M16x2

## Tabla de prensados para conexiones compactas en acero inoxidable

Tableau de sertissage pour les embouts pré-sertis en acier inoxydable | Crimping table for compact fittings in stainless steel | Tabella di pressatura per raccordi compatti in acciaio inox

Tolerancias de prensado (mm) | Tolerance de sertissage | Crimping tolerances | Toleranza di pressatura  
1/8" - 3/8" : + 0 / - 0,2 | 1/2" - 2" 1/2 . + 0 / - 0,4

Manguera   Tuyau Hose   Tubo	DN (mm)	6	8	10	12	16	19	25	32	38	50
	Pulgadas   Pouces   Inch   Inches	1/4"	5/16"	3/8"	1/2"	5/8"	3/4"	1"	1" 1/4	1" 1/2	2"
	Galga   Píges   Size   Gauge	04	05	06	08	10	12	16	20	24	32
SAE 100 R1AT EN 853 1SN ML2230 MS2230	Casquillo   Jupe   Ferrule   Boccia	ZPFC221200400	ZPFC221200500	ZPFC221200600	ZPFC221200800	ZPFC221201000	ZPFC221201200	ZPFC221201600	ZPFC221202000	ZPFC221202400	ZPFC221203200
	Ø Ext. casquillo   Jupe   Ferrule   Boccia	23	23,8	27,3	29	34	38	47	59	67	80
	Ø Ext. manguera   Tuyau   Hose   Tubo	13,4	15	17,4	20,6	23,7	27,7	35,6	44,8	50,4	64
	Ø Prensado   Sertissage   Crimping   Pressatura	17,1	18,9	20	23,8	27,4	31,5	38,5	48,8	57	70
SAE 100 R2AT EN 853 2SN ML3511 MS3511	Casquillo   Jupe   Ferrule   Boccia	ZPFC221200400	ZPFC221200500	ZPFC221200600	ZPFC221200800	ZPFC221201000	ZPFC221201200	ZPFC221201600	ZPFC221202000	ZPFC221202400	ZPFC221203200
	Ø Ext. casquillo   Jupe   Ferrule   Boccia	23	23,8	27,3	29	34	38	47	59	67	80
	Ø Ext. manguera   Tuyau   Hose   Tubo	15	16,6	19	22,2	25,4	29,3	38,1	47,2	54,2	66,7
	Ø Prensado   Sertissage   Crimping   Pressatura	18,2	20,1	21,6	24,8	29	32,2	40	51,8	60	72,5
SAE 100 R16 M4900	Casquillo   Jupe   Ferrule   Boccia	ZPFC221200400		ZPFC221200600	ZPFC221200800						
	Ø Ext. casquillo   Jupe   Ferrule   Boccia	23		27,3	29						
	Ø Ext. manguera   Tuyau   Hose   Tubo	12,3		16,9	20,5						
	Ø Prensado   Sertissage   Crimping   Pressatura	15		19	22,2						
SAE 100 R7 EN 855 R7 MT070 MT071	Casquillo   Jupe   Ferrule   Boccia	880120400	880120500	880120600	880120800	880121000	880121200	880121600			
	Ø Ext. casquillo   Jupe   Ferrule   Boccia	16	19	22	22		31,5	40			
	Ø Ext. manguera   Tuyau   Hose   Tubo	12,2	14,3	16	20,3	on proofs	27	34			
	Ø Prensado   Sertissage   Crimping   Pressatura	14,6	15,9	18,6	23		28,4	37			
SAE 100 R8 EN 855 R8 MT080 MT081	Casquillo   Jupe   Ferrule   Boccia	880120400	880120500	880120600	880120800	880121000	880121200	880121600			
	Ø Ext. casquillo   Jupe   Ferrule   Boccia	16	19	22	22						
	Ø Ext. manguera   Tuyau   Hose   Tubo	11,5	13,4	15,5	13	on proofs	on proofs	on proofs			
	Ø Prensado   Sertissage   Crimping   Pressatura	14,3	15,7	18,3	23,2						
SMOOTH PTFE M2900	Casquillo   Jupe   Ferrule   Boccia	880400400	880400500	880400600	880400800	880401000	880401200	880401600			
	Ø Ext. casquillo   Jupe   Ferrule   Boccia	15	on proofs	18	24	on proofs	30	40			
	Ø Prensado   Sertissage   Crimping   Pressatura	13		16,5	20,5		27	33,1			
CONVOLUTED PTFE M2920	Casquillo   Jupe   Ferrule   Boccia	880410400	880410500	880410600	880410800	880411000	880411200	880411600			
	Ø Ext. casquillo   Jupe   Ferrule   Boccia			21,5	25	on proofs	on proofs	on proofs			
	Ø Prensado   Sertissage   Crimping   Pressatura	on proofs	on proofs	16,1	19,2						

## Tabla de prensados para conexiones alimentarias en acero inoxidable

Tableau sertissage pour les jupes alimentaires en acier inoxydable | Crimping table for food fittings in stainless steel | Tabella di pressatura per raccordi alimentari in acciaio inox

Tolerancias de prensado (mm) | Tolerance de sertissage | Crimping tolerances | Toleranza di pressatura  
+ 0 / - 0,4

Manguera   Tuyau Hose   Tubo	Casquillo   Jupe   Ferrule   Boccia			Presión trabajo (bar) Pression de travail Working pressure Pressione di Lavoro	Presión rotura (bar) Pression de rupture Burst pressure Pressione di Scoppio	Ø prensado (mm) Ø sertissage Ø crimping Ø pressatura
	Código   Code Part number   Codice	Ø ext. (mm)	Ø int. (mm)			
MAS025   (25x35)   1"	810422540	46	40	10	30	40,5
MAS032   (32x45)   1" 1/4	810423248	55	48,5	10	30	47,5
MAS038   (38x50)   1" 1/2	810423852	58,5	52,5	10	30	52,5
MAS051   (51x65)   2"	810425069	76	69	10	30	68,5
MAS063   (63,5x78,5)   2" 1/2	810426580	88	80	10	30	83,4
MAS076   (76x90)   3"	810427595	103	94,5	10	30	95

NOTA: Las tablas de prensado DICSAs son siempre orientativas | Tableau sertissage DICSAs sont toujours indicatifs | Crimping lists of DICSAs are always orientatives | Le tabelle di pressatura DICSAs sono sempre orientative.

Los diámetros de prensado han sido validados para estos diámetros exteriores de manguera. Por lo tanto, estos diámetros pueden variar dependiendo de la manguera | Les diámetros de sertissage ont été vérifiés pour ces diámetros de tuyau. C'est pourquoi, ces diámetros peuvent changer selon le tuyau | Crimping diameters have been validated for these outer diameters of the hoses. Therefore, these diameters can change depending on the hose | I diametri di pressatura sono stati testati per questi diametri esterni di tubo. Saranno quindi passibili di variazione con el variare della natura dei tubi.

Datos de tablas siempre actualizados en nuestra web [www.dicsaes.com](http://www.dicsaes.com) | Information des tableaux toujours actualisés sur notre web [www.dicsaes.com](http://www.dicsaes.com) | Crimping information always updated on our website [www.dicsaes.com](http://www.dicsaes.com) | I dati delle tabelle sono sempre aggiornati nella pagina web [www.dicsaes.com](http://www.dicsaes.com).

# Tabla de prensados para casquillos en acero inoxidable (mangueras hidráulicas)

Tableau de sertissage pour les jupes en acier inoxydable (tuyaux hydrauliques) | Crimping table for stainless steel (hydraulic hoses) | Tabella di Pressatura per boccole in acciaio inox (tubi idraulici)

Tolerancias de prensado (mm) | Tolerance de sertissage | Crimping tolerances | Toleranza di pressatura  
1/8" - 3/8" : + 0 / - 0,2 | 1/2" - 2" 1/2 . + 0 / - 0,4

Manguera   Tuyau Hose   Tubo	DN (mm)	5	6	8	10	12	16	19	25	31	38	51
	Pulgadas   Pouces   Inch   Inches	3/16"	1/4"	5/16"	3/8"	1/2"	5/8"	3/4"	1"	1 1/4"	1 1/2"	2"
	Galga   Piges   Size   Gauge	03	04	05	06	08	10	12	16	20	24	32
EN 857 1SC MS1SC	Casquillo   Jupe   Ferrule   Boccolla	-	81014	81014	81014	81014	-	-	-	-	-	-
	Ø Ext. casquillo   Jupe   Ferrule   Boccolla		18	19	22	26						
	Ø Ext. manguera   Tuyau   Hose   Tubo		13	14,2	16,5	19,5						
	Ø Prensado   Sertissage   Crimping   Pressatura		15,8	16,8	19	23,6						
EN 857 2SC MS2SC	Casquillo   Jupe   Ferrule   Boccolla	-	ZPF2212	ZPF2212	ZPF2212	ZPF2212	ZPF2212	ZPF2212	ZPF2212	-	-	-
	Ø Ext. casquillo   Jupe   Ferrule   Boccolla		23	24	26	29	33	37,5	46			
	Ø Ext. manguera   Tuyau   Hose   Tubo		14	15,8	17	20,6	24,5	27,7	36,3			
	Ø Prensado   Sertissage   Crimping   Pressatura		18,1	18,9	20,9	23,6	27,6	31	39			
SAE 100 R1AT EN 853 1SN ML2230 MS2230	Casquillo   Jupe   Ferrule   Boccolla	81020	ZPF2212	ZPF2212	ZPF2212	ZPF2212	ZPF2212	ZPF2212	ZPF2212	ZPF2212	ZPF2212	ZPF2212
	Ø Ext. casquillo   Jupe   Ferrule   Boccolla	19	23	24	26	29	33	37,5	46	59	67	80
	Ø Ext. manguera   Tuyau   Hose   Tubo	11,5	13,1	15,4	17,5	20,3	23,9	28,2	35,3	44	50,3	64
	Ø Prensado   Sertissage   Crimping   Pressatura	15,7	17,5	19,2	20,8	23,1	27,5	31,5	39,1	48,8	57	70
	Pelado exterior   Denudage ext.   Ext. Skive   Pelatura esterna	-	-	-	-	-	-	-	-	-	-	-
SAE 100 R2AT EN 853 2SN ML3511 MS3511	Casquillo   Jupe   Ferrule   Boccolla	81030	ZPF2212	ZPF2212	ZPF2212	ZPF2212	ZPF2212	ZPF2212	ZPF2212	ZPF2212	ZPF2212	ZPF2212
	Ø Ext. casquillo   Jupe   Ferrule   Boccolla	21	23	24	26	29	33	37,5	46	59	67	80
	Ø Ext. manguera   Tuyau   Hose   Tubo	13,2	14,2	16,6	18,9	22	25,3	29	37	47,5	54,3	66,7
	Ø Prensado   Sertissage   Crimping   Pressatura	16,2	18	19,8	22	24,2	28,7	32,6	40,5	51,8	60	72,5
	Pelado exterior   Denudage ext.   Ext. Skive   Pelatura esterna	-	-	-	-	-	-	-	-	-	-	-
SAE 100 R1A EN 853 1ST ML2231	Casquillo   Jupe   Ferrule   Boccolla	82003	82003	82003	82003	82003	82003	82003	82003	82003	82003	82003
	Ø Ext. casquillo   Jupe   Ferrule   Boccolla	18	20	21	24	28	31	35	42	52	58	71
	Ø Prensado   Sertissage   Crimping   Pressatura	15,5	17,8	18,8	21,7	25,2	28,8	32,5	38,8	49	55	66
	Pelado exterior   Denudage ext.   Ext. Skive   Pelatura esterna	22,5	22,5	22,5	22,5	26	27	31	39	45	50	58
SAE 100 R2A EN 853 2ST ML3509 MS3509	Casquillo   Ferrule   Jupe   Boccolla	ZPF1224	ZPF1224	ZPF1224	ZPF1224	ZPF1224	ZPF1224	ZPF1224	ZPF1224	ZPF1224	ZPF1224	ZPF1224
	Ø Ext. casquillo   Ferrule   Jupe   Boccolla	21	22	23	26	30	33	38	46	57	65	79
	Ø Prensado   Sertissage   Crimping   Pressatura	18,2	17,6	20	22,5	26,3	29,1	33,8	42,2	51	59	72,3
	Pelado exterior   Denudage ext.   Ext. Skive   Pelatura esterna	22,5	21	22	23	23	26,5	31	38	45	49	60
SAE 100 R9R EN 856 4SP ML4290 / ML4248 MS4290 / MS4248	Casquillo   Jupe   Ferrule   Boccolla	-	ZPF1224	-	ZPF1224	ZPF1224	ZPF1224	ZPF1224	ZPF1224	ZPF1224	ZPF1224	ZPF1224
	Ø Ext. casquillo   Jupe   Ferrule   Boccolla		22		26	30	33	38	46	57	65	79
	Ø Prensado   Sertissage   Crimping   Pressatura		18,8		23,4	26,7	29,7	34,4	42,2	51,7	59,3	73
	Pelado exterior   Denudage ext.   Ext. Skive   Pelatura esterna		21		23	23,5	26,5	31	38	45	49	60
SAE 100 R12 EN 856 R12 M4612	Casquillo   Jupe   Ferrule   Boccolla	-	-	-	ZPF1224	ZPF1224	ZPF1224	ZPF1224	ZPF1224	ZPF1224	ZPF1224	-
	Ø Ext. casquillo   Jupe   Ferrule   Boccolla				26	30	33	38	46	57	65	
	Ø Prensado   Sertissage   Crimping   Pressatura				23,3	26,7	29,3	34,4	42,2	50,5	58,8	
	Pelado exterior   Denudage ext.   Ext. Skive   Pelatura esterna				23	23,5	27	31	38	45	49	
EN 856 4SH Conex.interlock M4569	Casquillo   Jupe   Ferrule   Boccolla	-	-	-	-	-	-	ZA61010	ZA61010	ZA61010	ZA61010	ZA61010
	Ø Ext. casquillo   Jupe   Ferrule   Boccolla							40	47	56	63	80
	Ø Prensado   Sertissage   Crimping   Pressatura							35,5	42	50	57	74
	Pelado int.   Denudage int.   Inn. Skive   Pelatura interna							17	18	21	24	26
	Pelado exterior   Denudage ext.   Ext. Skive   Pelatura esterna							52	57	64	77	82
SAE 100 R13 EN 856 R13 Conex.interlock M4713	Casquillo   Jupe   Ferrule   Boccolla	-	-	-	-	-	-	ZA61010	ZA61010	Z61010	Z61010	Z61010
	Ø Ext. casquillo   Jupe   Ferrule   Boccolla							40	47	61	70	85
	Ø Ext. manguera   Tuyau   Hose   Tubo							32,1	38,3	49,7	57,2	70,8
	Ø Prensado   Sertissage   Crimping   Pressatura							36	42,5	55	64	79
	Pelado int.   Denudage int.   Inn. Skive   Pelatura interna							17	18	21	24	26
	Pelado exterior   Denudage ext.   Ext. Skive   Pelatura esterna							52	57	64	77	82
SAE 100 R15 Conex.interlock M4815	Casquillo   Jupe   Ferrule   Boccolla	-	-	-	-	-	-	ZA61010	ZA61010	Z61010	Z61010	-
	Ø Ext. casquillo   Jupe   Ferrule   Boccolla							40	47	61	70	
	Ø Prensado   Sertissage   Crimping   Pressatura							35,5	42	54,5	64	
	Pelado int.   Denudage int.   Inn. Skive   Pelatura interna							17	18	21	24	
	Pelado exterior   Denudage ext.   Ext. Skive   Pelatura esterna							52	57	64	77	
SAE 100 R16 M4900	Casquillo   Jupe   Ferrule   Boccolla		ZPF2212		ZPF2212	ZPF2212						
	Ø Ext. casquillo   Jupe   Ferrule   Boccolla		23		26	29						
	Ø Ext. manguera   Tuyau   Hose   Tubo		12,3		16,8	20,7						
	Ø Prensado   Sertissage   Crimping   Pressatura		17,5		20,5	23,9						

NOTA: Las tablas de prensado DICSА son siempre orientativas | Les tableaux de sertissage DICSА sont toujours indicatifs | Crimping lists of DICSА are always orientatives | Le tabbelle di pressatura DICSА sono sempre orientative.

Los diámetros de prensado han sido validados para estos diámetros exteriores de manguera. Por lo tanto, éstos diámetros pueden variar dependiendo de la manguera | Les diamètres de sertissage ont été vérifiés pour ces diamètres de tuyau. C'est pourquoi, ces diamètres peuvent changer selon le tuyau | Crimping diameters have been validated for these outer diameters of the hoses. Therefore, these diameters can change depending on the hose | I diametri di pressatura sono stati testati per questi diametri esterni di tubo. Saranno quindi passibili di variazione con il variare Della natura dei tubi.

Datos de tablas siempre actualizados en nuestra web [www.dicsaes.com](http://www.dicsaes.com) | Information des tableaux toujours actualisés sur notre web [www.dicsaes.com](http://www.dicsaes.com) | Crimping information always updated on our website [www.dicsaes.com](http://www.dicsaes.com) | I dati delle tabelle sono sempre aggiornati nella pagina web [www.dicsaes.com](http://www.dicsaes.com).

# Tabla de prensados para casquillos en acero inoxidable (mangueras de PTFE y termoplásticas)

Tableau sertissage pour les jupes en acier inoxydable (tuyaux PTFE et thermoplastiques) | Crimping table for stainless steel (PTFE and thermoplastic hoses) | Tabella di Pressatura per boccole in acciaio inox (PTFE e tubi termoplastica)

Tolerancias de prensado (mm) | Tolerance de sertissage | Crimping tolerances | Toleranza di pressatura  
1/8" - 3/8" : + 0 / - 0,2 | 1/2" - 2" 1/2 : + 0 / - 0,4

Manguera   Tuyau   Hose   Tubo	DN (mm)	3	5	6	8	10	13	16	19	22	25	32	38	50	63
	Pulgadas   Pouces   Inch   Inches	1/8"	3/16"	1/4"	5/16"	3/8"	1/2"	5/8"	3/4"	7/8"	1"	1 1/4"	1 1/2"	2"	2 1/2"
	Gaige   Piges   Size   Gauge	02	03	04	05	06	08	10	12	14	16	20	24	32	40
PTFE FHL M2900	Casquillo   Jupe   Ferrule   Boccola	-	81040	81040	81040	81040	81040	81040	81040	81040	81040	-	-	-	-
	Ø Ext. casquillo   Jupe   Ferrule   Boccola		14	15	17	18	24	28	30	34	36				
	Ø Prensado   Sertissage   Crimping   Pressatura		11,5	13	13,8	15,5	20,5	23,5	27	30,5	34				
PTFE FHM (2 mallas   2 tresses   2 braids   2 trecce) M29012	Casquillo   Jupe   Ferrule   Boccola	-	-	81014	81014	81014	81040	81040	81040	-	81041	-	-	-	-
	Ø Ext. casquillo   Jupe   Ferrule   Boccola			18	19	22	24	28	30		40				
	Ø Prensado   Sertissage   Crimping   Pressatura			13,6	14,6	17,5	20,7	25,2	27,5		34,1				
PTFE (corrugado   convoluted   convoluted PTFE   corrugato) M2920 (1)	Casquillo   Jupe   Ferrule   Boccola	-	-	81041	81041	81041	81041	81041	81041	-	81041	81041	81041	81041	81041
	Ø Ext. casquillo   Jupe   Ferrule   Boccola			16	17	21,5	25	29	34		40	46	55	69	80
	Ø Prensado   Sertissage   Crimping   Pressatura			12,2	14	16,8	20,2	24	26,3		34	39	48,2	60,2	74
SAE 100 R7 MT070 / MT071	Casquillo   Jupe   Ferrule   Boccola	81012	81014	81014	81014	81014	81014	81012	81014	-	81014	-	-	-	-
	Ø Ext. casquillo   Jupe   Ferrule   Boccola	13	14	18	19	22	26	29	31,5		40				
	Ø Ext. manguera   Tuyau   Hose   Tubo (2)	8,4	9,6	12	14,3	16	20,3	24,3	27,2		34,5				
	Ø Prensado   Sertissage   Crimping   Pressatura	11	11,2	14,6	16,5	18,6	23	26	28,4		37				
SAE 100 R8 MT080 / MT081	Casquillo   Jupe   Ferrule   Boccola	-	81014	81014	81014	81014	81014	81012	81012	-	81012	-	-	-	-
	Ø Ext. casquillo   Jupe   Ferrule   Boccola		14	18	19	22	26	29	31,5		40				
	Ø Ext. manguera   Tuyau   Hose   Tubo (2)		9,4	11,5	13,3	15,5	19,9	23,4	27		34,2				
	Ø Prensado   Sertissage   Crimping   Pressatura		11,1	14,3	15,7	18,3	23	26	29		37				
Elastomero malla metálica   Élastomère 1 tresse métallique   Metallic braid elastomer   Maglia metalica per vernici M2090	Casquillo   Jupe   Ferrule   Boccola	-	81014	81014	81014	81014	81014	81012	81014	-	81014	-	-	-	-
	Ø Ext. casquillo   Jupe   Ferrule   Boccola		14	18	19	22	26	29	31,5		40				
	Ø Ext. manguera   Tuyau   Hose   Tubo (2)		9,4	11,7	13,4	15,9	18,4	21,6	25,5						
	Ø Prensado   Sertissage   Crimping   Pressatura		11,1	14,5	15,8	18,5	22	25	28		36,5				
Elast. malla metálica pintura   Élast. peint. 1 tresse métallique   Paint metallic braid elastomer   Maglia metalica per vernici M2099	Casquillo   Jupe   Ferrule   Boccola	-	81014	82003	81012	82003	82003	-	82003	-	81012	-	-	-	-
	Ø Ext. casquillo   Jupe   Ferrule   Boccola		14	20	19	24	28		35		40				
	Ø Prensado   Sertissage   Crimping   Pressatura		11,1	17,9	16,5	21	22,5		31		36,5				
Elast. doble malla metal. pintura   Élast. peint. 2 tresses metal.   Paint metal. braid double elastomer   Doppia Maglia metal. per vernici M2299	Casquillo   Jupe   Ferrule   Boccola	-	-	ZPF1224	ZPF1224	ZPF1224	ZPF1224	-	ZPF2212	-	ZPF1224	-	-	-	-
	Ø Ext. casquillo   Jupe   Ferrule   Boccola			22	23	26	30		37		46				
	Ø Prensado   Sertissage   Crimping   Pressatura			17,3	19	22	26		30,6		41				
Manguera altísima presión   Haute pression   High pressure Altissima pressione M2700	Casquillo   Jupe   Ferrule   Boccola	-	-	Z71012	-	Z71012	Z71012	-	-	-	-	-	-	-	-
	Ø Ext. casquillo   Jupe   Ferrule   Boccola			20		26	33,7								
	Ø Ext. manguera   Tuyau   Hose   Tubo (2)			12,7		18,8	25,3								
	Ø Prensado   Sertissage   Crimping   Pressatura			16,6		22,8	28,5								
Ecology 200 MEC200...	Casquillo   Jupe   Ferrule   Boccola	-	-	-	-	-	-	-	Z21200	-	Z21200	-	-	-	-
	Ø Ext. casquillo   Jupe   Ferrule   Boccola								42		49				
	Ø Ext. manguera   Tuyau   Hose   Tubo (2)								31,2		39				
	Ø Prensado   Sertissage   Crimping   Pressatura								35,9		43,5				
Limpieza de alcantarillas   Tuyau Hydrocurage   Sewer jetting hose   Pulizia fossa biologica ML2250	Casquillo   Jupe   Ferrule   Boccola	-	-	-	-	-	-	-	Z21200	-	Z21200	-	-	-	-
	Ø Ext. casquillo   Jupe   Ferrule   Boccola								42		49				
	Ø Ext. manguera   Tuyau   Hose   Tubo (2)								31,5		39,8				
	Ø Prensado   Sertissage   Crimping   Pressatura								37,2		45				
Manguera Minimex 2x5mm   Tuyau Minimex   Minimex hose   Tubo Minimex MT01002	Casquillo   Jupe   Ferrule   Boccola	Z55501	-	-	-	-	-	-	-	-	-	-	-	-	-
	Ø Ext. casquillo   Jupe   Ferrule   Boccola	8													
	Ø Ext. manguera   Tuyau   Hose   Tubo (2)	5													
	Ø Prensado   Sertissage   Crimping   Pressatura	7													

NOTA: Las tablas de prensado DICSAs son siempre orientativas | Les tableaux de sertissage DICSAs sont toujours indicatifs | Crimping lists of DICSAs are always orientatives | Le tabelle di pressatura DICSAs sono sempre orientative.

(1) Los diámetros de prensado de las mangueras de PTFE corrugado, se corresponden con los ensayos para mangueras de nuestro proveedor. Por lo tanto estos diámetros pueden variar dependiendo de la manguera. Se recomienda, que en diámetros de prensado de 1 1/4", 1 1/2" y 2" se comprueben todos los montajes que se realicen | Les diamètres de sertissage du PTFE convoluted sont suite aux diamètres de sertissage des tuyaux de notre fournisseur. C'est pourquoi, ces diamètres peuvent changer selon le tuyau. Pour diamètres de sertissage de 1 1/4", 1 1/2" et 2", on recommande de vérifier tous les montages | Crimping diameters of convoluted PTFE are according the tests of crimping diameters for hoses of our supplier. Therefore, these diameters can change depending on the hose. For crimping diameters 1 1/4", 1 1/2" and 2", it is recommended to check all the assemblies | I diametri di pressatura relativi al tubo PTFE corrugado, sono stati ottenuti e testati sui tubi del nostro programma di vendita. Questi diametri potranno quindi cambiare, al cambiare della loro origine. Nei diametri 1 1/4", 1 1/2" e 2" è consigliato il controllo della pressatura di ogni singolo tubo assemblato.

(2) Los diámetros de prensado han sido validados para estos diámetros exteriores de manguera. Por lo tanto, éstos diámetros pueden variar dependiendo de la manguera | Les diamètres de sertissage ont été vérifiés pour ces diamètres de tuyau. C'est pourquoi, ces diamètres peuvent changer selon le tuyau | Crimping diameters have been validated for these outer diameters of the hoses. Therefore, these diameters can change depending on the hose | I diametri di pressatura sono stati testati per questi diametri esterni di tubo. Saranno quindi passibili di variazione con il variare Della natura dei tubi.

Datos de tablas siempre actualizados en nuestra web [www.dicsaes.com](http://www.dicsaes.com) | Information des tableaux toujours actualisés sur notre web [www.dicsaes.com](http://www.dicsaes.com) | Crimping information always updated on our website [www.dicsaes.com](http://www.dicsaes.com) | I dati delle tabelle sono sempre aggiornati nella pagina web [www.dicsaes.com](http://www.dicsaes.com).

## Máquinas tratamiento tubo flexible

Machines pour le montage des flexibles | Machines for mounting flexibles | Macchine per l'assemblaggio di tubi flessibili

### ▶ SE 28 (1" 1/4 4 SP)



137 t +28 mm 100 mm

### ▶ PE 58 (2" 6 SP)



305 t +54 mm 180 mm

### ▶ SPEBDEG



### ▶ CHMT-20 (1"1/4)



Ø Disco-250mm  
Pot. Motor 2,2 KW

### ▶ CHM4-32D (2")



### ▶ PBC-32



### ▶ Portarrollos | Porte-Rouleaux Roll-Holder | Portarrotoli



### ▶ Banco de pruebas BE 1500 / BE 2500 | Banque d'essais BE 1500 / BE 2500 Testing bank BE 1500 / BE 2500 | Banco de prova BE 1500 / BE 2500



Opcional | Optionnel  
Optional | Opzionale





Racores para tubo rígido DIN 2353

Raccord tube rigide DIN 2353

Pipe fittings DIN 2353

Raccordi ad anello DIN 2353

▶ Tubo rígido

Tube rigide | Rigid pipe | Tubo rigido

82

▶ Racores DIN 2353

Raccords à bague DIN 2353 | DIN 2353 Pipe fittings | Raccordi DIN 2353

83

▶ Abrazaderas

Colliers | Clamps | Collari fissatubo

86

Una solución eficaz, económica y sencilla para prevenir el goteo en las conducciones de tubo rígido

Une solution efficace, Économique et simple pour prévenir les fuites dans les émbouts pour tube rigide | An effective, cheap and single solution to prevent leaks in pipe fittings | Una soluzione efficace, economica e semplice per prevenire perdite dai raccordi per tubo rigido



- Óptima prevención de fugas
- Larga durabilidad
- Fácil montaje, revisión y sustitución
- Protección antivibraciones
- Excelente resistencia a altas temperaturas y fluidos agresivos

- Bonne prévention de fuites
- Longue durée
- Facile montage, inspection et substitution
- Protection Anti-vibration
- Excellente résistance aux hautes températures et fluides agressifs

- Good leakage prevention
- Long self
- Easy assembly, inspection, replacement
- Anti-vibration and unscrewing protection
- Excellent resistance to high temperatures and aggressive fluids

- Buona prevenzione delle perdite
- Lunga durata
- Facile montaggio, ispezione e sostituzione
- Antivibrazione e protezione allo svitamento
- Eccellente resistenza alle alte temperature e fluidi aggressivi

#### Información técnica | Information technique | Technical data | Informazione tecnica

Material | Matériel | Material | Materiale

FKM verde 70/80 sh | FKM vert 70/80 sh | Green FKM 70/80 sh | FKM verde 70/80 sh

Temperatura | Temperature | Temperature | Temperatura

-35°C + 100°C

Durabilidad | Durée | Self life | Durata

5 años | 5 an | 5 year | 5 anni

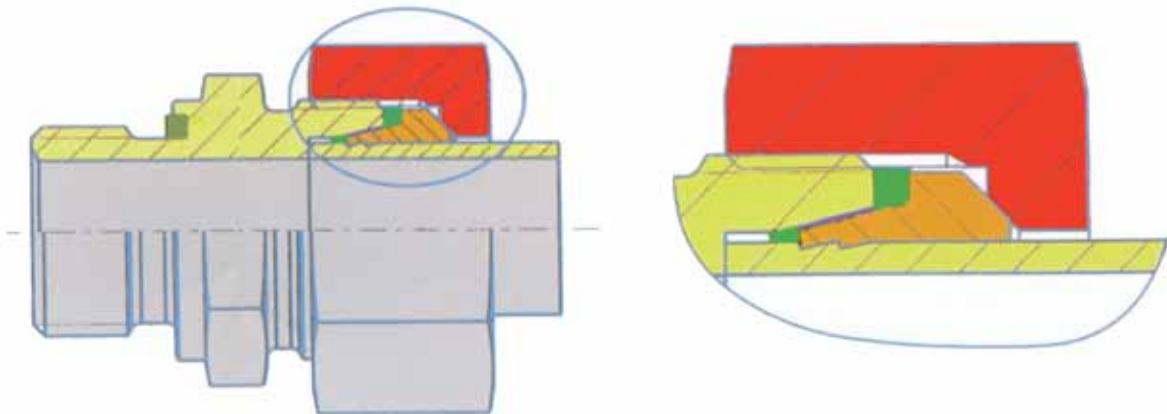

## Racores DIN 2353

Raccords à bague DIN 2353 | DIN 2353 Pipe fittings | Raccordi DIN 2353

**Instrucciones de montaje del racor DIN 2353 sobre el tubo rígido (se recomienda el uso de herramientas de premontaje)**  
 | **Instructions de montage du raccord DIN 2353 sur le tube rigide (Nous recommandons l'utilisation d'outils)** | **Assembly of the pipe fittings DIN 2353 in the rigid pipe (It is recommended to use pre-assembly tools)** | **Assemblaggio del raccordo ad anello DIN 2353 nel tubo rigido (è si consiglia l'uso degli utensili di premontaggio)**

### A. Preparación del tubo | Préparation du tube | Preparation of the tube | Preparazione del tubo

**Altura mínima (H)**  
 | Hauteur minimale (H) | Minimum Height (H) | Minima lunghezza diritta (H)

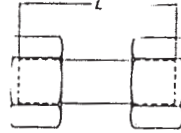
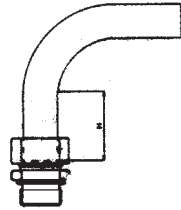

**Longitud mínima (L)**  
 | Longueur minimale (L) | Minimum Length (L) | Minima lunghezza (L)



**Cortar el tubo a escuadra y eliminar rebabas** | Couper le tube à angle droit et entever les bavures | Rectangularly saw off the pipe and remove all burrs | Tagliare il tubo ad angolo retto ed eliminare i residui metallici

	Serie   Série   Series   Serie		
	LL	L	S
Ø exterior Ø extérieur Ø outer Ø esterno	4-5-6-8	6-8-10-12-15-18-22-28-35-42	6-8-10-12-14-16-20-25-30-38
H mínimo H minimum H minimum H minimo	24-25-25-26	31-31-33-33-36-38-42-42-48-48	35-35-37-37-43-43-50-54-58-65
L mínimo L minimum L minimum L minimo	30-32-32-33	39-39-42-42-45-48-53-53-60-60	44-44-47-47-54-54-63-68-73-82

**B. Lubricar adecuadamente**  
 | Lubrifier convenablement | Lubricate property | Lubrificare convenientemente

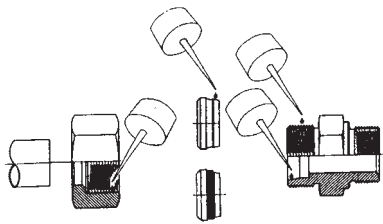

**C. Montaje | Montage | Assembly | Montaggio**

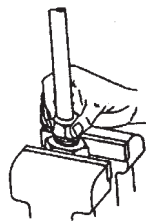

**D. Apriete | Blockage | Blocking | Bloccaggio**

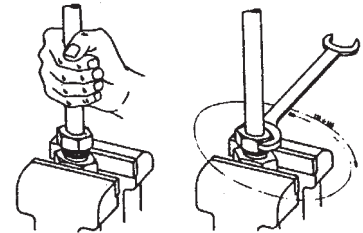

**E. Control | Control | Control | Controllo**

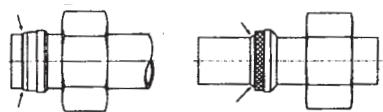

**F. Montaje final | Montage final | Final assembly | Montaggio finale**

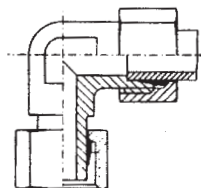

**G. Montajes posteriores | Montages posterieurs | Later assemblies | Montaggio successivo**

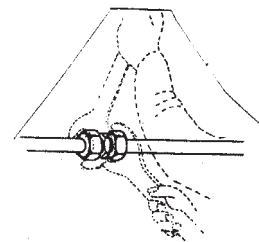

# ▶ Tubo rígido

Tube rigide | Rigid pipe | Tubo rigido

Crimp fittings for hoses

Pipe fittings DIN 2353

Flare fittings JIC  
SAE flanges

Adaptors

Welding fittings

Industrial fittings

Several items





## ▶ **Tubo rígido** | Tube rigide | Rigid pipe | Tubo rigido

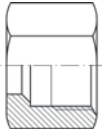

ZTH0

# Racores DIN 2353

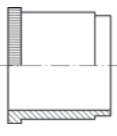
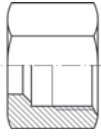
Raccords à bague DIN 2353 | DIN 2353 Pipe fittings | Raccordi DIN 2353

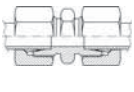
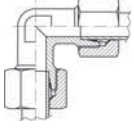
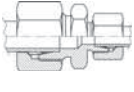
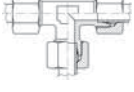
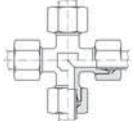
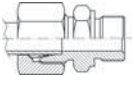
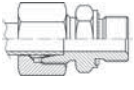
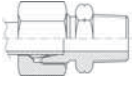
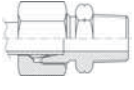
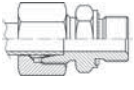
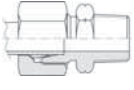
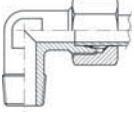
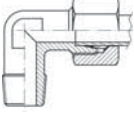
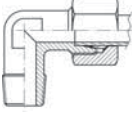
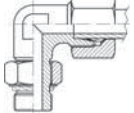
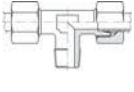
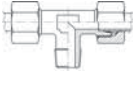
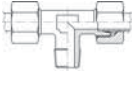
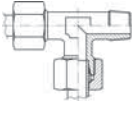
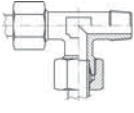
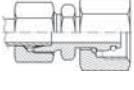
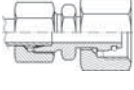
▶	<b>Tuercas y anillos</b>   Écrous et bagues   Nuts and cutting rings   Dadi e anelli	88
	     	
	ZML/ZMS      VA0      ZACL/ZACS      ZVHS      ZEML/ZEMS      ZIACL/ZIACS	
▶	<b>Uniones tubo-tubo</b>   Raccords union double   Straight couplings   Raccordi intermedi	90
	    	
	ZDL/ZDS      ZEL/ZES      ZDL/ZDS      ZTL/ZTS      ZKVL/ZKVS	
▶	<b>Uniones rectas tubo-rosca</b>   Raccords union simple mâle   Straight male stud couplings   Raccordi di estremità diritti	92
	     	
	ZAL/ZAS BSP      ZAL/ZAS BSP WD      ZAKL/ZAKS NPT      ZAKL/ZAKS BSPT      ZAL/ZAS M WD      ZAKL/ZAKS METRIC	
▶	<b>Codos tubo-rosca</b>   Raccords coude mâle gaz   Male stud elbows   Raccordi di estremità a 90°	95
	   	
	ZCKL/ZCKS BSPT      ZCKL/ZCKS METRIC      ZCKL/ZCKS NPT      Z WEE	
▶	<b>TES rosca central</b>   Raccords Té mâle central   Male stud branch   Raccordi di estremità a T	96
	  	
	ZFKL/ZFKS BSPT      ZFKL/ZFKS METRIC      ZFKL/ZFKS NPT	
▶	<b>TES rosca lateral</b>   Raccords Té mâle latéral   Male stud barrel   Raccordi di estremità a L	97
	 	
	ZLKL/ZLKS BSPT      ZLKL/ZLKS METRIC	
▶	<b>Uniones Métricas</b>   Raccords union Métrique   Metric unions   Raccordi Metrici	98
	 	
	ZKORL TLM      ZKORS TLM	

▶ **Reducciones roscadas** | Raccords réduction | Reducers | Raccordi di riduzione filettati

99

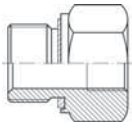

ZRI-R WD

▶ **Racores regulables** | Raccords réglables | Adjustable stud couplings | Raccordi orientabili

100

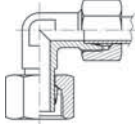

ZEEL/ZEES CTA

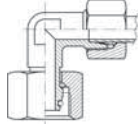

ZEEL/ZEES TLM

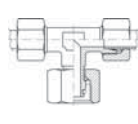

ZTEL/ZTES TLM

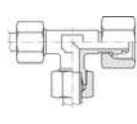

ZLEL/ZLES TLM

▶ **Tubo roscado (hembra giratoria)** | Raccords tube fileté | Adjustable straight stud | Raccordi di estremità per combinazioni

101

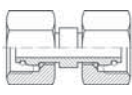

ZATL/ZATS

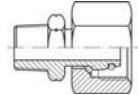
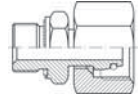
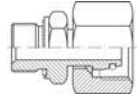
ZRAL/ZRAS NPT  
TLMZRAL/ZRAS BSP  
TLM WDZRAL/ZRAS  
METRIC TLM WD

▶ **Soldables** | Raccords à souder | Weld | Raccordi a saldare

102

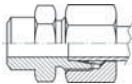

ZASL/ZASS

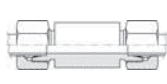

ZESVL/ZESVS

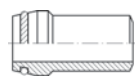

ZORIL/ZORIS

▶ **Pasatabiques** | Raccords passe cloison | Bulkhead | Raccordi di attraversamento

103



ZSVL/ZSVS

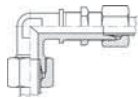

ZUSVL/ZUSVS



KZTPM

▶ **Racor recto hembra** | Raccords droits femelle | Straight female coupling | Raccordi diritti con estremità femmina

104

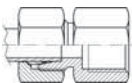
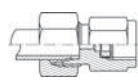
ZGAIL/ZGAIS  
BSPZGAIL/ZGAIS  
METRIC

ZMAVL/ZMAVS



ZAM

▶ **Orientables** | Raccords orientables | Banjos | Raccordi orientabili ad occhio

105

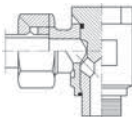
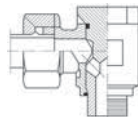
ZWSVL/ZWSVS  
BSPZWSVL/ZWSVS  
METRIC

▶ **Tapones** | Raccords bouchon métrique | Plugs | Tappi

106

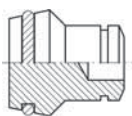

ZBUTZEN L/S



ZSTOPFEN BSP

ZSTOPFEN  
METRIC

▶ **Juntas** | Joints | O-rings & captive seals | Guarnizioni

107



JVT



JVBSP/JVM

▶ **Accesorios para montaje** | Accessoires pour le montage | Accessories for the assembly | Accessori per assemblaggio

107

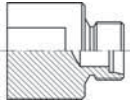

ZVOMO



Grasa

▶ **Válvulas antirretorno** | Valves clapet antiretour | Valves | Valvole di ritegno

108

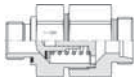

ZRHVL/ZRHVS

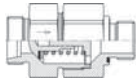

ZRHZL/ZRHZS

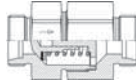

ZRHDL/ZRHDS

# Abrazaderas

Colliers | Clamps | Collari fissatubo

## ▶ **Abrazaderas completas serie ligera** | Colliers complets série légère | Clamps complete light serie | Collari fissatubo completo serie leggera 109



ZA40AZ



ZA41AZ

## ▶ **Componentes abrazaderas serie ligera** | Composants pour colliers série légère | Components for clamps light serie | Componenti per collari fissatubo serie leggera 110



A C



ZAPIN



ZAPS



ZAVTC



ZAVTE

## ▶ **Dobles / paralelas** | Colliers de fixation doubles | Double clamp - parallel | Collari fissatubo doppi 111



ZAZCFS



ZADPIN



ZADPS



AD C



ZADVTE

## ▶ **Componentes abrazaderas serie pesada** | Composants pour colliers série lourde | Components for clamps heavy serie | Componenti per collari fissatubo serie pesante 112



TC/TS



AMPP C



ZAPINP



ZAPSP



ZAVTE



## Tubo rígido

Tube rigide  
Rigid pipe  
Tubo rigido

### Tubo rígido



Tube rigide  
Rigid pipe  
Tubo rigido

Ø ext Ø outer	Ø in	Pr.Trabajo (bar) WP (bar)	Kg/m	REFERENCIA PART N°	€
8	6	368	0,175	ZTH0080100	
10	7	441	0,318	ZTH0100150	
12	9	368	0,393	ZTH0120150	
14	10	420	0,600	ZTH0140200	
15	12	294	0,506	ZTH0150150	
16	12	368	0,700	ZTH0160200	
18	15	245	0,618	ZTH0180150	
20	14	441	1,275	ZTH0200300	
22	18	267	1	ZTH0220200	
25	19	353	1,650	ZTH0250300	
28	24	210	1,302	ZTH0280200	
30	24	294	2,028	ZTH0300300	
35	31	168	1,653	ZTH0350200	
38	30	309	3,405	ZTH0380400	
42	36	210	2,930	ZTH0420300	



## Racores DIN 2353

Raccords à bague DIN 2353  
DIN 2353 Pipe fittings  
Raccordi DIN 2353

### Tuercas Métricas DIN 3870



Écrou DIN 3870  
Nuts DIN 3870  
Dado DIN 3870

TUBO PIPE	SERIE	ROSCA THREAD	REFERENCIA PART N°	€
4	LL	M8X1	Z MLL 4	
6	LL	M10X1	Z MLL 6	
8	LL	M12X1	Z MLL 8	
6	L	M12X1.5	Z ML 6	
8	L	M14X1.5	Z ML 8	
10	L	M16X1.5	Z ML 10	
12	L	M18X1.5	Z ML 12	
15	L	M22X1.5	Z ML 15	
18	L	M26X1.5	Z ML 18	
22	L	M30X2	Z ML 22	
28	L	M36X2	Z ML 28	
35	L	M45X2	Z ML 35	
42	L	M52X2	Z ML 42	
6	S	M14X1.5	Z MS 6	
8	S	M16X1.5	Z MS 8	
10	S	M18X1.5	Z MS 10	
12	S	M20X1.5	Z MS 12	
14	S	M22X1.5	Z MS 14	
16	S	M24X1.5	Z MS 16	
20	S	M30X2	Z MS 20	
25	S	M36X2	Z MS 25	
30	S	M42X2	Z MS 30	
38	S	M52X2	Z MS 38	

### Anillos de corte DIN 3861



Bague DIN 3861  
Cutting rings DIN 3861  
Anello DIN 3861

TUBO PIPE	SERIE	REFERENCIA PART N°	€
4	LL	Z ACLL 4	
6	LL	Z ACLL 6	
8	LL	Z ACLL 8	
6	L/S	Z ACL 6	
8	L/S	Z ACL 8	
10	L/S	Z ACL 10	
12	L/S	Z ACL 12	
15	L	Z ACL 15	
18	L	Z ACL 18	
22	L	Z ACL 22	
28	L	Z ACL 28	
35	L	Z ACL 35	
42	L	Z ACL 42	
14	S	Z ACS 14	
16	S	Z ACS 16	
20	S	Z ACS 20	
25	S	Z ACS 25	
30	S	Z ACS 30	
38	S	Z ACS 38	

### Anillo de refuerzo

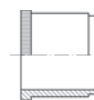

Bague de renforcement  
Reinforced ring  
Anello di rinforzo

TUBO PIPE	REFERENCIA PART N°	€
4	Z VHS 4	
5	Z VHS 5	
6	Z VHS 6	
7	Z VHS 7	
8	Z VHS 8	
9	Z VHS 9	
10	Z VHS 10	
11	Z VHS 11	
12	Z VHS 12	
13	Z VHS 13	
14	Z VHS 14	
15	Z VHS 15	
16	Z VHS 16	
17	Z VHS 17	
18	Z VHS 18	
19	Z VHS 19	
20	Z VHS 20	
22	Z VHS 22	
24	Z VHS 24	
25	Z VHS 25	
31	Z VHS 31	
33	Z VHS 33	
38	Z VHS 38	

### Anillo FKM anti-fuga



Joint FKM anti-fuite  
FKM ring for leaking prevent  
Anello FKM anti-fuga

TUBO PIPE	SERIE	REFERENCIA PART N°	€
6	L/S	VA006L	
8	L/S	VA008L	
10	L/S	VA010L	
12	L/S	VA012L	
15	L	VA015L	
18	L	VA018L	
22	L	VA022L	
28	L	VA028L	
35	L	VA035L	
42	L	VA042L	
14	S	VA014S	
16	S	VA016S	
20	S	VA020S	
25	S	VA025S	
30	S	VA030S	
38	S	VA038S	

## Racores DIN 2353

Raccords à bague DIN 2353  
DIN 2353 Pipe fittings  
Raccordi DIN 2353

### Tuercas métricas antigripaje

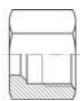

Écrou métrique intérieur argenté  
Metric Nut inside silver-plated  
Dado metrico interno argentato

TUBO PIPE	SERIE	ROSCA THREAD	REFERENCIA PART N°	€
6	L	M12X1.5	<b>Z EML 6</b>	
8	L	M14X1.5	<b>Z EML 8</b>	
10	L	M16X1.5	<b>Z EML 10</b>	
12	L	M18X1.5	<b>Z EML 12</b>	
15	L	M22X1.5	<b>Z EML 15</b>	
18	L	M26X1.5	<b>Z EML 18</b>	
22	L	M30X2	<b>Z EML 22</b>	
6	S	M14X1.5	<b>Z EMS 6</b>	
8	S	M16X1.5	<b>Z EMS 8</b>	
10	S	M18X1.5	<b>Z EMS 10</b>	
12	S	M20X1.5	<b>Z EMS 12</b>	
14	S	M22X1.5	<b>Z EMS 14</b>	
16	S	M24X1.5	<b>Z EMS 16</b>	
20	S	M30X2	<b>Z EMS 20</b>	
25	S	M36X2	<b>Z EMS 25</b>	

### Anillo de corte sin tratamiento térmico



Bague sans traitement thermique  
Cutting ring without heat treatment  
Anello senza trattamento termico

TUBO PIPE	SERIE	REFERENCIA PART N°	€
6	L / S	<b>Z IAACL 6</b>	
8	L / S	<b>Z IAACL 8</b>	
10	L / S	<b>Z IAACL 10</b>	
12	L / S	<b>Z IAACL 12</b>	
15	L	<b>Z IAACL 15</b>	
18	L	<b>Z IAACL 18</b>	
22	L	<b>Z IAACL 22</b>	
14	S	<b>Z IAACS 14</b>	
16	S	<b>Z IAACS 16</b>	
20	S	<b>Z IAACS 20</b>	
25	S	<b>Z IAACS 25</b>	

Recomendado en ambientes corrosivos//Recommandé dans des environnements  
corrosifs//Recommended for corrosive environments//Consigliato per ambienti corrosivi

## Racores DIN 2353

Raccords à bague DIN 2353  
DIN 2353 Pipe fittings  
Raccordi DIN 2353

### Racor unión recta tubo - tubo



Raccord union double

Straight coupling

Raccordo intermedio diritto

TUBO PIPE	SERIE	REFERENCIA PART N°	€	REFERENCIA STA PART N° STA	€
4	LL	Z DLL 4			
6	LL	Z DLL 6			
8	LL	Z DLL 8			
6	L	Z DL 6		Z STA DL 6	
8	L	Z DL 8		Z STA DL 8	
10	L	Z DL 10		Z STA DL 10	
12	L	Z DL 12		Z STA DL 12	
15	L	Z DL 15		Z STA DL 15	
18	L	Z DL 18		Z STA DL 18	
22	L	Z DL 22		Z STA DL 22	
28	L	Z DL 28		Z STA DL 28	
35	L	Z DL 35		Z STA DL 35	
42	L	Z DL 42		Z STA DL 42	
6	S	Z DS 6		Z STA DS 6	
8	S	Z DS 8		Z STA DS 8	
10	S	Z DS 10		Z STA DS 10	
12	S	Z DS 12		Z STA DS 12	
14	S	Z DS 14		Z STA DS 14	
16	S	Z DS 16		Z STA DS 16	
20	S	Z DS 20		Z STA DS 20	
25	S	Z DS 25		Z STA DS 25	
30	S	Z DS 30		Z STA DS 30	
38	S	Z DS 38		Z STA DS 38	

### Racor unión recta en reducción tubo - tubo

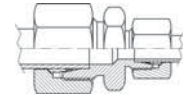

Raccord union double en réduction

Straight reducing coupling

Raccordo di riduzione

TUBO PIPE	SERIE	REFERENCIA PART N°	€
8	6	L	Z DL 8-6
10	6	L	Z DL 10-6
10	8	L	Z DL 10-8
12	6	L	Z DL 12-6
12	8	L	Z DL 12-8
12	10	L	Z DL 12-10
15	6	L	Z DL 15-6
15	8	L	Z DL 15-8
15	10	L	Z DL 15-10
15	12	L	Z DL 15-12
18	8	L	Z DL 18-8
18	10	L	Z DL 18-10
18	12	L	Z DL 18-12
18	15	L	Z DL 18-15
22	12	L	Z DL 22-12
22	15	L	Z DL 22-15
22	18	L	Z DL 22-18
28	22	L	Z DL 28-22
35	28	L	Z DL 35-28
42	28	L	Z DL 42-28
42	35	L	Z DL 42-35
8	6	S	Z DS 8-6
10	6	S	Z DS 10-6
10	8	S	Z DS 10-8
12	6	S	Z DS 12-6
12	8	S	Z DS 12-8
12	10	S	Z DS 12-10
14	10	S	Z DS 14-10
16	10	S	Z DS 16-10
16	12	S	Z DS 16-12
16	14	S	Z DS 16-14
20	12	S	Z DS 20-12
20	14	S	Z DS 20-14
20	16	S	Z DS 20-16
25	16	S	Z DS 25-16
25	20	S	Z DS 25-20
30	20	S	Z DS 30-20
30	25	S	Z DS 30-25
38	25	S	Z DS 38-25
38	30	S	Z DS 38-30

### Racor unión en codo tubo - tubo



Raccord coude égal

Equal elbow coupling

Raccordo intermedio a 90°

TUBO PIPE	SERIE	REFERENCIA PART N°	€	REFERENCIA STA PART N° STA	€
4	LL	Z ELL 4			
6	LL	Z ELL 6			
8	LL	Z ELL 8			
6	L	Z EL 6		Z STA EL 6	
8	L	Z EL 8		Z STA EL 8	
10	L	Z EL 10		Z STA EL 10	
12	L	Z EL 12		Z STA EL 12	
15	L	Z EL 15		Z STA EL 15	
18	L	Z EL 18		Z STA EL 18	
22	L	Z EL 22		Z STA EL 22	
28	L	Z EL 28		Z STA EL 28	
35	L	Z EL 35		Z STA EL 35	
42	L	Z EL 42		Z STA EL 42	
6	S	Z ES 6		Z STA ES 6	
8	S	Z ES 8		Z STA ES 8	
10	S	Z ES 10		Z STA ES 10	
12	S	Z ES 12		Z STA ES 12	
14	S	Z ES 14		Z STA ES 14	
16	S	Z ES 16		Z STA ES 16	
20	S	Z ES 20		Z STA ES 20	
25	S	Z ES 25		Z STA ES 25	
30	S	Z ES 30		Z STA ES 30	
38	S	Z ES 38		Z STA ES 38	

## Racores DIN 2353

Raccords à bague DIN 2353  
DIN 2353 Pipe fittings  
Raccordi DIN 2353

### Racor unión en T tubo - tubo



#### Raccord Té égal

##### Equal Tee

##### Raccordo intermedio a T

TUBO PIPE	SERIE	REFERENCIA PART N°	€	REFERENCIA STA PART N° STA	€
4	LL	Z TLL 4			
6	LL	Z TLL 6			
8	LL	Z TLL 8			
6	L	Z TL 6		Z STA TL 6	
8	L	Z TL 8		Z STA TL 8	
10	L	Z TL 10		Z STA TL 10	
12	L	Z TL 12		Z STA TL 12	
15	L	Z TL 15		Z STA TL 15	
18	L	Z TL 18		Z STA TL 18	
22	L	Z TL 22		Z STA TL 22	
28	L	Z TL 28		Z STA TL 28	
35	L	Z TL 35		Z STA TL 35	
42	L	Z TL 42		Z STA TL 42	
6	S	Z TS 6		Z STA TS 6	
8	S	Z TS 8		Z STA TS 8	
10	S	Z TS 10		Z STA TS 10	
12	S	Z TS 12		Z STA TS 12	
14	S	Z TS 14		Z STA TS 14	
16	S	Z TS 16		Z STA TS 16	
20	S	Z TS 20		Z STA TS 20	
25	S	Z TS 25		Z STA TS 25	
30	S	Z TS 30		Z STA TS 30	
38	S	Z TS 38		Z STA TS 38	

### Racor unión en cruz tubo - tubo



#### Raccord croix égale

##### Equal cross

##### Raccordo intermedio a croce

TUBO PIPE	SERIE	REFERENCIA PART N°	€
6	L	Z KVL 6	
8	L	Z KVL 8	
10	L	Z KVL 10	
12	L	Z KVL 12	
15	L	Z KVL 15	
18	L	Z KVL 18	
22	L	Z KVL 22	
28	L	Z KVL 28	
35	L	Z KVL 35	
42	L	Z KVL 42	
6	S	Z KVS 6	
8	S	Z KVS 8	
10	S	Z KVS 10	
12	S	Z KVS 12	
14	S	Z KVS 14	
16	S	Z KVS 16	
20	S	Z KVS 20	
25	S	Z KVS 25	
30	S	Z KVS 30	
38	S	Z KVS 38	

# Racores DIN 2353

Raccords à bague DIN 2353  
DIN 2353 Pipe fittings  
Raccordi DIN 2353

## Racor recto rosca cilíndrica BSP



Raccord union simple gaz cylindrique mâle  
Straight male stud coupling BSP cylindrical  
Raccordo di estremità diritto BSP

T. P.	S.	ROSCA THREAD	REFERENCIA PART N°	€	REFERENCIA STA PART N° STA	€
6	L	1/8" BSP	Z AL 6 R 1/8		Z STA AL 6 R 1/8	
6	L	1/4" BSP	Z AL 6 R 1/4		Z STA AL 6 R 1/4	
6	L	3/8" BSP	Z AL 6 R 3/8			
8	L	1/8" BSP	Z AL 8 R 1/8		Z STA AL 8 R 1/8	
8	L	1/4" BSP	Z AL 8 R 1/4		Z STA AL 8 R 1/4	
8	L	3/8" BSP	Z AL 8 R 3/8		Z STA AL 8 R 3/8	
8	L	1/2" BSP	Z AL 8 R 1/2			
10	L	1/8" BSP	Z AL 10 R 1/8			
10	L	1/4" BSP	Z AL 10 R 1/4		Z STA AL 10 R 1/4	
10	L	3/8" BSP	Z AL 10 R 3/8		Z STA AL 10 R 3/8	
10	L	1/2" BSP	Z AL 10 R 1/2		Z STA AL 10 R 1/2	
12	L	1/4" BSP	Z AL 12 R 1/4		Z STA AL 12 R 1/4	
12	L	3/8" BSP	Z AL 12 R 3/8		Z STA AL 12 R 3/8	
12	L	1/2" BSP	Z AL 12 R 1/2		Z STA AL 12 R 1/2	
15	L	3/8" BSP	Z AL 15 R 3/8		Z STA AL 15 R 3/8	
15	L	1/2" BSP	Z AL 15 R 1/2		Z STA AL 15 R 1/2	
15	L	3/4" BSP	Z AL 15 R 3/4			
18	L	1/2" BSP	Z AL 18 R 1/2		Z STA AL 18 R 1/2	
18	L	3/4" BSP	Z AL 18 R 3/4		Z STA AL 18 R 3/4	
22	L	3/8" BSP	Z AL 22 R 3/8			
22	L	1/2" BSP	Z AL 22 R 1/2		Z STA AL 22 R 1/2	
22	L	3/4" BSP	Z AL 22 R 3/4		Z STA AL 22 R 3/4	
22	L	1" BSP	Z AL 22 R 1		Z STA AL 22 R 1	
28	L	3/4" BSP	Z AL 28 R 3/4		Z STA AL 28 R 3/4	
28	L	1" BSP	Z AL 28 R 1		Z STA AL 28 R 1	
35	L	1"1/4 BSP	Z AL 35 R 1 1/4		Z STA AL 35 R 1 1/4	
35	L	1"1/2 BSP	Z AL 35 R 1 1/2			
42	L	1"1/2 BSP	Z AL 42 R 1 1/2		Z STA AL 42 R 1 1/2	
6	S	1/4" BSP	Z AS 6 R 1/4		Z STA AS 6 R 1/4	
6	S	3/8" BSP	Z AS 6 R 3/8			
8	S	1/4" BSP	Z AS 8 R 1/4		Z STA AS 8 R 1/4	
8	S	3/8" BSP	Z AS 8 R 3/8			
8	S	1/2" BSP	Z AS 8 R 1/2			
10	S	1/4" BSP	Z AS 10 R 1/4		Z STA AS 10 R 1/4	
10	S	3/8" BSP	Z AS 10 R 3/8		Z STA AS 10 R 3/8	
10	S	1/2" BSP	Z AS 10 R 1/2		Z STA AS 10 R 1/2	
12	S	1/4" BSP	Z AS 12 R 1/4		Z STA AS 12 R 1/4	
12	S	3/8" BSP	Z AS 12 R 3/8		Z STA AS 12 R 3/8	
12	S	1/2" BSP	Z AS 12 R 1/2		Z STA AS 12 R 1/2	
14	S	3/8" BSP	Z AS 14 R 3/8			
14	S	1/2" BSP	Z AS 14 R 1/2		Z STA AS 14 R 1/2	
16	S	3/8" BSP	Z AS 16 R 3/8		Z STA AS 16 R 3/8	
16	S	1/2" BSP	Z AS 16 R 1/2		Z STA AS 16 R 1/2	
16	S	3/4" BSP	Z AS 16 R 3/4		Z STA AS 16 R 3/4	
20	S	1/2" BSP	Z AS 20 R 1/2		Z STA AS 20 R 1/2	
20	S	3/4" BSP	Z AS 20 R 3/4		Z STA AS 20 R 3/4	
20	S	1" BSP	Z AS 20 R 1		Z STA AS 20 R 1	
25	S	3/4" BSP	Z AS 25 R 3/4		Z STA AS 25 R 3/4	
25	S	1" BSP	Z AS 25 R 1		Z STA AS 25 R 1	
30	S	1" BSP	Z AS 30 R 1		Z STA AS 30 R 1	
30	S	1"1/2 BSP	Z AS 30 R 1 1/2			
38	S	1"1/4 BSP	Z AS 38 R 1 1/4		Z STA AS 38 R 1 1/4	
38	S	1"1/2 BSP	Z AS 38 R 1 1/2		Z STA AS 38 R 1 1/2	

## Racor recto rosca cilíndrica BSP con junta



Raccord union simple mâle gaz cylindrique avec o'ring  
Straight male stud coupling BSP cylindrical with o'ring  
Raccordo di estremità diritto BSP con guarnizione

T. P.	S.	ROSCA THREAD	REFERENCIA PART N°	€	REFERENCIA STA PART N° STA	€
6	L	1/8" BSP	Z AL 6 R 1/8WD		Z STA AL 6 R 1/8WD	
6	L	1/4" BSP	Z AL 6 R 1/4WD		Z STA AL 6 R 1/4WD	
6	L	3/8" BSP	Z AL 6 R 3/8WD			
8	L	1/8" BSP	Z AL 8 R 1/8WD		Z STA AL 8 R 1/8WD	
8	L	1/4" BSP	Z AL 8 R 1/4WD		Z STA AL 8 R 1/4WD	
8	L	3/8" BSP	Z AL 8 R 3/8WD		Z STA AL 8 R 3/8WD	
8	L	1/2" BSP	Z AL 8 R 1/2WD			
10	L	1/8" BSP	Z AL 10 R 1/8WD		Z STA AL 10 R 1/8WD	
10	L	1/4" BSP	Z AL 10 R 1/4WD		Z STA AL 10 R 1/4WD	
10	L	3/8" BSP	Z AL 10 R 3/8WD		Z STA AL 10 R 3/8WD	
10	L	1/2" BSP	Z AL 10 R 1/2WD		Z STA AL 10 R 1/2WD	
12	L	1/4" BSP	Z AL 12 R 1/4WD		Z STA AL 12 R 1/4WD	
12	L	3/8" BSP	Z AL 12 R 3/8WD		Z STA AL 12 R 3/8WD	
12	L	1/2" BSP	Z AL 12 R 1/2WD		Z STA AL 12 R 1/2WD	
15	L	3/8" BSP	Z AL 15 R 3/8WD		Z STA AL 15 R 3/8WD	
15	L	1/2" BSP	Z AL 15 R 1/2WD		Z STA AL 15 R 1/2WD	
15	L	3/4" BSP	Z AL 15 R 3/4WD			
18	L	1/2" BSP	Z AL 18 R 1/2WD		Z STA AL 18 R 1/2WD	
18	L	3/4" BSP	Z AL 18 R 3/4WD		Z STA AL 18 R 3/4WD	
22	L	1/2" BSP	Z AL 22 R 1/2WD		Z STA AL 22 R 1/2WD	
22	L	3/4" BSP	Z AL 22 R 3/4WD		Z STA AL 22 R 3/4WD	
22	L	1" BSP	Z AL 22 R 1WD		Z STA AL 22 R 1WD	
28	L	3/4" BSP	Z AL 28 R 3/4WD		Z STA AL 28 R 3/4WD	
28	L	1" BSP	Z AL 28 R 1WD		Z STA AL 28 R 1WD	
35	L	1" BSP	Z AL 35 R 1WD		Z STA AL 35 R 1WD	
35	L	1"1/4 BSP	Z AL 35 R 1 1/4WD		Z STA AL 35 R 1 1/4WD	
42	L	1"1/2 BSP	Z AL 42 R 1 1/2WD		Z STA AL 42 R 1 1/2WD	
6	S	1/4" BSP	Z AS 6 R 1/4WD		Z STA AS 6 R 1/4WD	
8	S	1/4" BSP	Z AS 8 R 1/4WD		Z STA AS 8 R 1/4WD	
8	S	3/8" BSP	Z AS 8 R 3/8WD		Z STA AS 8 R 3/8WD	
8	S	1/2" BSP	Z AS 8 R 1/2WD			
10	S	1/4" BSP	Z AS 10 R 1/4WD		Z STA AS 10 R 1/4WD	
10	S	3/8" BSP	Z AS 10 R 3/8WD		Z STA AS 10 R 3/8WD	
10	S	1/2" BSP	Z AS 10 R 1/2WD		Z STA AS 10 R 1/2WD	
12	S	1/4" BSP	Z AS 12 R 1/4WD		Z STA AS 12 R 1/4WD	
12	S	3/8" BSP	Z AS 12 R 3/8WD		Z STA AS 12 R 3/8WD	
12	S	1/2" BSP	Z AS 12 R 1/2WD		Z STA AS 12 R 1/2WD	
14	S	3/8" BSP	Z AS 14 R 3/8WD		Z STA AS 14 R 3/8WD	
14	S	1/2" BSP	Z AS 14 R 1/2WD		Z STA AS 14 R 1/2WD	
16	S	3/8" BSP	Z AS 16 R 3/8WD		Z STA AS 16 R 3/8WD	
16	S	1/2" BSP	Z AS 16 R 1/2WD		Z STA AS 16 R 1/2WD	
16	S	3/4" BSP	Z AS 16 R 3/4WD		Z STA AS 16 R 3/4WD	
20	S	1/2" BSP	Z AS 20 R 1/2WD		Z STA AS 20 R 1/2WD	
20	S	3/4" BSP	Z AS 20 R 3/4WD		Z STA AS 20 R 3/4WD	
25	S	3/4" BSP	Z AS 25 R 3/4WD		Z STA AS 25 R 3/4WD	
25	S	1" BSP	Z AS 25 R 1WD		Z STA AS 25 R 1WD	
25	S	1"1/4 BSP	Z AS 25 R 1 1/4WD			
30	S	1" BSP	Z AS 30 R 1WD		Z STA AS 30 R 1WD	
30	S	1"1/4 BSP	Z AS 30 R 1 1/4WD		Z STA AS 30 R 1 1/4WD	
30	S	1"1/2 BSP	Z AS 30 R 1 1/2WD			
38	S	1"1/4 BSP	Z AS 38 R 1 1/4WD		Z STA AS 38 R 1 1/4WD	
38	S	1"1/2 BSP	Z AS 38 R 1 1/2WD		Z STA AS 38 R 1 1/2WD	

## Racores DIN 2353

Raccords à bague DIN 2353  
DIN 2353 Pipe fittings  
Raccordi DIN 2353

### Racor recto rosca cónica NPT



Raccord union simple mâle NPT  
Straight male stud coupling NPT  
Raccordo di estremità diritto NPT

T. P.	S.	ROSCA THREAD	REFERENCIA PART N°	€	REFERENCIA STA PART N° STA	€
6	L	1/8 NPT	Z AKL 6 1/8 NPT		Z STA AKL 6 1/8 NPT	
6	L	1/4 NPT	Z AKL 6 1/4 NPT		Z STA AKL 6 1/4 NPT	
6	L	3/8 NPT	Z AKL 6 3/8 NPT			
8	L	1/8 NPT	Z AKL 8 1/8 NPT		Z STA AKL 8 1/8 NPT	
8	L	1/4 NPT	Z AKL 8 1/4 NPT		Z STA AKL 8 1/4 NPT	
8	L	3/8 NPT	Z AKL 8 3/8 NPT			
8	L	1/2 NPT	Z AKL 8 1/2 NPT			
10	L	1/4"NPT	Z AKL 10 1/4 NPT		Z STA AKL 10 1/4 NPT	
10	L	3/8"NPT	Z AKL 10 3/8 NPT			
10	L	1/2"NPT	Z AKL 10 1/2 NPT			
12	L	1/4"NPT	Z AKL 12 1/4 NPT		Z STA AKL 12 1/4 NPT	
12	L	3/8"NPT	Z AKL 12 3/8 NPT		Z STA AKL 12 3/8 NPT	
12	L	1/2"NPT	Z AKL 12 1/2 NPT		Z STA AKL 12 1/2 NPT	
15	L	3/8"NPT	Z AKL 15 3/8 NPT			
15	L	1/2"NPT	Z AKL 15 1/2 NPT		Z STA AKL 15 1/2 NPT	
18	L	1/2"NPT	Z AKL 18 1/2 NPT		Z STA AKL 18 1/2 NPT	
18	L	3/4"NPT	Z AKL 18 3/4 NPT		Z STA AKL 18 3/4 NPT	
22	L	3/4"NPT	Z AKL 22 3/4 NPT			
28	L	1"NPT	Z AKL 28 1 NPT			
35	L	1"1/4 NPT	Z AKL 35 1 1/4 NPT			
42	L	1"1/2 NPT	Z AKL 42 1 1/2 NPT			
6	S	1/8 NPT	Z AKS 6 1/8 NPT			
6	S	1/4 NPT	Z AKS 6 1/4 NPT		Z STA AKS 6 1/4 NPT	
6	S	3/8 NPT	Z AKS 6 3/8 NPT			
8	S	1/4 NPT	Z AKS 8 1/4 NPT		Z STA AKS 8 1/4 NPT	
8	S	3/8 NPT	Z AKS 8 3/8 NPT			
8	S	1/2 NPT	Z AKS 8 1/2 NPT			
10	S	1/4 NPT	Z AKS 10 1/4 NPT			
10	S	3/8 NPT	Z AKS 10 3/8 NPT			
10	S	1/2 NPT	Z AKS 10 1/2 NPT			
12	S	1/4 NPT	Z AKS 12 1/4 NPT			
12	S	3/8 NPT	Z AKS 12 3/8 NPT			
12	S	1/2 NPT	Z AKS 12 1/2 NPT			
14	S	1/2 NPT	Z AKS 14 1/2 NPT		Z STA AKS 14 1/2 NPT	
16	S	1/2 NPT	Z AKS 16 1/2 NPT		Z STA AKS 16 1/2 NPT	
16	S	3/4 NPT	Z AKS 16 3/4 NPT			
20	S	1/2 NPT	Z AKS 20 1/2 NPT			
20	S	3/4 NPT	Z AKS 20 3/4 NPT		Z STA AKS 20 3/4 NPT	
20	S	1"NPT	Z AKS 20 1 NPT			
25	S	3/4 NPT	Z AKS 25 3/4 NPT			
25	S	1"NPT	Z AKS 25 1 NPT		Z STA AKS 25 1 NPT	
30	S	1"NPT	Z AKS 30 1 NPT			
30	S	1"1/4 NPT	Z AKS 30 1 1/4 NPT			
38	S	1"1/2 NPT	Z AKS 38 1 1/2 NPT			

### Racor recto rosca cónica BSPT



Raccord union simple mâle conique  
Straight male stud coupling BSPT  
Raccordo di estremità diritto BSP conico

T. P.	S.	ROSCA THREAD	REFERENCIA PART N°	€	REFERENCIA STA PART N° STA	€
6	LL	1/8" BSPT	Z AKLL 6 R 1/8			
8	LL	1/8" BSPT	Z AKLL 8 R 1/8			
6	L	1/8" BSPT	Z AKL 6 R 1/8		Z STA AKL 6 R 1/8	
6	L	1/4" BSPT	Z AKL 6 R 1/4		Z STA AKL 6 R 1/4	
8	L	1/8" BSPT	Z AKL 8 R 1/8			
8	L	1/4" BSPT	Z AKL 8 R 1/4		Z STA AKL 8 R 1/4	
8	L	3/8" BSPT	Z AKL 8 R 3/8			
10	L	1/4" BSPT	Z AKL 10 R 1/4		Z STA AKL 10 R 1/4	
10	L	3/8" BSPT	Z AKL 10 R 3/8		Z STA AKL 10 R 3/8	
10	L	1/2" BSPT	Z AKL 10 R 1/2			
12	L	1/4" BSPT	Z AKL 12 R 1/4		Z STA AKL 12 R 1/4	
12	L	3/8" BSPT	Z AKL 12 R 3/8		Z STA AKL 12 R 3/8	
12	L	1/2" BSPT	Z AKL 12 R 1/2		Z STA AKL 12 R 1/2	
15	L	3/8" BSPT	Z AKL 15 R 3/8			
15	L	1/2" BSPT	Z AKL 15 R 1/2		Z STA AKL 15 R 1/2	
18	L	1/2" BSPT	Z AKL 18 R 1/2		Z STA AKL 18 R 1/2	
22	L	3/4" BSPT	Z AKL 22 R 3/4		Z STA AKL 22 R 3/4	
28	L	1" BSPT	Z AKL 28 R 1		Z STA AKL 28 R 1	
35	L	1"1/4 BSPT	Z AKL 35 R 1 1/4			
42	L	1"1/4 BSPT	Z AKL 42 R 1 1/4			
6	S	1/4" BSPT	Z AKS 6 R 1/4			
8	S	1/4" BSPT	Z AKS 8 R 1/4			
10	S	3/8" BSPT	Z AKS 10 R 3/8			
14	S	1/2" BSPT	Z AKS 14 R 1/2			
16	S	1/2" BSPT	Z AKS 16 R 1/2		Z STA AKS 16 R 1/2	
20	S	3/4" BSPT	Z AKS 20 R 3/4			
25	S	1" BSPT	Z AKS 25 R 1			
30	S	1"1/4 BSPT	Z AKS 30 R 1 1/4			

## Racores DIN 2353

Raccords à bague DIN 2353  
DIN 2353 Pipe fittings  
Raccordi DIN 2353

### Racor recto rosca cilíndrica Métrica con junta



Raccord union simple mâle cylindrique Métrique avec o'ring  
Straight male stud coupling Metric cylindrical with o'ring  
Raccordo di estremità diritto Metrico con guarnizione

T. P.	S.	ROSCA THREAD	REFERENCIA PART N°	€	REFERENCIA PART N°	€
6	L	M10x1	Z AL 6 M 10X1 WD		Z AL 6 M 10X1	
8	L	M12x1.5	Z AL 8 M 12X1.5 WD		Z AL 8 M 12X1.5	
10	L	M14x1.5	Z AL 10 M 12X1.5 WD			
10	L	M14x1.5	Z AL 10 M 14X1.5 WD		Z AL 10 M 14X1.5	
10	L	M16x1.5	Z AL 10 M 16X1.5 WD			
12	L	M16x1.5	Z AL 12 M 16X1.5 WD		Z AL 12 M 16X1.5	
12	L	M18x1.5	Z AL 12 M 18X1.5 WD			
12	L	M22x1.5	Z AL 12 M 22X1.5 WD			
15	L	M18x1.5	Z AL 15 M 18X1.5 WD		Z AL 15 M 18X1.5	
18	L	M22x1.5	Z AL 18 M 22X1.5 WD		Z AL 18 M 22X1.5	
22	L	M26x1.5	Z AL 22 M 26X1.5 WD		Z AL 22 M 26X1.5	
28	L	M33x2	Z AL 28 M 33X2 WD			
35	L	M42x2	Z AL 35 M 42X2 WD			
42	L	M48x2	Z AL 42 M 48X2 WD			
6	S	M12x1.5	Z AS 6 M 12X1.5 WD			
6	S	M14x1.5	Z AS 6 M 14X1.5 WD			
8	S	M14x1.5	Z AS 8 M 14X1.5 WD		Z AS 8 M 14X1.5	
10	S	M16x1.5	Z AS 10 M 16X1.5 WD			
12	S	M14x1.5	Z AS 12 M 14X1.5 WD			
12	S	M18x1.5	Z AS 12 M 18X1.5 WD		Z AS 12 M 18X1.5	
14	S	M20x1.5	Z AS 14 M 20X1.5 WD			
16	S	M22x1.5	Z AS 16 M 22X1.5 WD			
20	S	M27x2	Z AS 20 M 27X2 WD		Z AS 20 M 27X2	
25	S	M33x2	Z AS 25 M 33X2 WD			
30	S	M42x2	Z AS 30 M 42X2 WD			
38	S	M48x2	Z AS 38 M 48X2 WD		Z AS 38 M 48X2	

Ref.sin WD hasta fin de existencias.Salvo indicación expresa del cliente se suministrará con o sin junta según disponibilidad//Ref.sans WD jusqu'à fin du stock.Sauf indication expresse du client, sera fourni avec ou sans o'ring selon disponibilité//Ref.without WD until end of stock.Unless otherwise indicated by the client, we will supply with or without o'ring depending on availability

### Racor recto rosca cónica Métrica

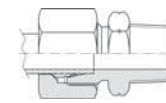

Raccord union simple mâle Métrique conique  
Straight male stud coupling Metric tapered  
Raccordo di estremità diritto Metrico conico

TUBO PIPE	SERIE	ROSCA THREAD	REFERENCIA PART N°	€
6	LL	M10X1	Z AKLL 6 M10X1	
8	LL	M10X1	Z AKLL 8 M10X1	
6	L	M10X1	Z AKL 6 M 10X1	
8	L	M12X1.5	Z AKL 8 M 12X1.5	
10	L	M14X1.5	Z AKL 10 M 14X1.5	
12	L	M16X1.5	Z AKL 12 M 16X1.5	
15	L	M18X1.5	Z AKL 15 M 18X1.5	
18	L	M22X1.5	Z AKL 18 M 22X1.5	
22	L	M26X1.5	Z AKL 22 M 26X1.5	



## Racores DIN 2353

Raccords à bague DIN 2353  
DIN 2353 Pipe fittings  
Raccordi DIN 2353

### Racor en codo rosca cónica BSPT



Raccord union coude mâle gaz conique  
Male stud elbow BSPT  
Raccordo di estremità a 90° BSP conico

T. P.	S.	ROSCA THREAD	REFERENCIA PART N°	€	REFERENCIA STA PART N° STA	€
6	LL	1/8"BSPT	Z CKL 6 R 1/8			
6	L	1/8" BSPT	Z CKL 6 R 1/8		Z STA CKL 6 R 1/8	
6	L	1/4" BSPT	Z CKL 6 R 1/4		Z STA CKL 6 R 1/4	
8	L	1/8" BSPT	Z CKL 8 R 1/8		Z STA CKL 8 R 1/8	
8	L	1/4" BSPT	Z CKL 8 R 1/4		Z STA CKL 8 R 1/4	
8	L	3/8" BSPT	Z CKL 8 R 3/8		Z STA CKL 8 R 3/8	
10	L	1/8" BSPT	Z CKL 10 R 1/8			
8	L	1/2" BSPT	Z CKL 8 R 1/2			
10	L	1/4" BSPT	Z CKL 10 R 1/4		Z STA CKL 10 R 1/4	
10	L	3/8" BSPT	Z CKL 10 R 3/8		Z STA CKL 10 R 3/8	
10	L	1/2" BSPT	Z CKL 10 R 1/2			
12	L	1/4" BSPT	Z CKL 12 R 1/4		Z STA CKL 12 R 1/4	
12	L	3/8" BSPT	Z CKL 12 R 3/8		Z STA CKL 12 R 3/8	
12	L	1/2" BSPT	Z CKL 12 R 1/2		Z STA CKL 12 R 1/2	
15	L	3/8" BSPT	Z CKL 15 R 3/8			
15	L	1/2" BSPT	Z CKL 15 R 1/2		Z STA CKL 15 R 1/2	
18	L	1/2" BSPT	Z CKL 18 R 1/2		Z STA CKL 18 R 1/2	
22	L	3/4" BSPT	Z CKL 22 R 3/4		Z STA CKL 22 R 3/4	
28	L	1" BSPT	Z CKL 28 R 1			
35	L	1 1/4" BSPT	Z CKL 35 R 1 1/4			
6	S	1/4" BSPT	Z CKS 6 R 1/4		Z STA CKS 6 R 1/4	
8	S	1/4" BSPT	Z CKS 8 R 1/4		Z STA CKS 8 R 1/4	
8	S	3/8" BSPT	Z CKS 8 R 3/8			
8	S	1/2" BSPT	Z CKS 8 R 1/2			
10	S	1/4" BSPT	Z CKS 10 R 1/4		Z STA CKS 10 R 1/4	
10	S	3/8" BSPT	Z CKS 10 R 3/8			
10	S	1/2" BSPT	Z CKS 10 R 1/2			
12	S	1/4" BSPT	Z CKS 12 R 1/4			
12	S	3/8" BSPT	Z CKS 12 R 3/8		Z STA CKS 12 R 3/8	
14	S	1/2" BSPT	Z CKS 14 R 1/2		Z STA CKS 14 R 1/2	
16	S	1/2" BSPT	Z CKS 16 R 1/2		Z STA CKS 16 R 1/2	
20	S	3/4" BSPT	Z CKS 20 R 3/4		Z STA CKS 20 R 3/4	
25	S	1" BSPT	Z CKS 25 R 1		Z STA CKS 25 R 1	
30	S	1 1/4" BSPT	Z CKS 30 R 1 1/4			
38	S	1 1/2" BSPT	Z CKS 38 R 1 1/2			

### Racor en codo rosca cónica Métrica

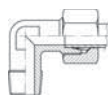

Raccord équerre mâle métrique  
Male stud elbow metrical tapered  
Raccordo di estremità a 90° Metrico conico

TUBO PIPE	SERIE	ROSCA THREAD	REFERENCIA PART N°	€
6	L	M10X1	Z CKL 6 M 10X1	
8	L	M12X1.5	Z CKL 8 M 12X1.5	
10	L	M14X1.5	Z CKL 10 M 14X1.5	
12	L	M16X1.5	Z CKL 12 M 16X1.5	
15	L	M18X1.5	Z CKL 15 M 18X1.5	
18	L	M22X1.5	Z CKL 18 M 22X1.5	
6	S	M12X1.5	Z CKS 6 M 12X1.5	
8	S	M14X1.5	Z CKS 8 M 14X1.5	
10	S	M16X1.5	Z CKS 10 M 16X1.5	
12	S	M18X1.5	Z CKS 12 M 18X1.5	
14	S	M20X1.5	Z CKS 14 M 20X1.5	
16	S	M22X1.5	Z CKS 16 M 22X1.5	

### Racor en codo rosca cónica NPT

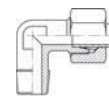

Raccord union coude mâle NPT  
Male stud elbow NPT  
Raccordo di estremità a 90° NPT

TUBO PIPE	SERIE	ROSCA THREAD	REFERENCIA PART N°	€
6	L	1/8" NPT	Z CKL 6 1/8 NPT	
6	L	1/4" NPT	Z CKL 6 1/4 NPT	
8	L	1/4" NPT	Z CKL 8 1/4 NPT	
10	L	1/4" NPT	Z CKL 10 1/4 NPT	
12	L	1/4" NPT	Z CKL 12 1/4 NPT	
12	L	3/8" NPT	Z CKL 12 3/8 NPT	
12	L	1/2" NPT	Z CKL 12 1/2 NPT	
15	L	1/2" NPT	Z CKL 15 1/2 NPT	
18	L	1/2" NPT	Z CKL 18 1/2 NPT	
22	L	3/4" NPT	Z CKL 22 3/4 NPT	
28	L	1" NPT	Z CKL 28 1 NPT	
35	L	1 1/4" NPT	Z CKL 35 1 1/4 NPT	
42	L	1 1/2" NPT	Z CKL 42 1 1/2 NPT	
6	S	1/4" NPT	Z CKS 6 1/4 NPT	
8	S	1/4" NPT	Z CKS 8 1/4 NPT	
10	S	3/8" NPT	Z CKS 10 3/8 NPT	
12	S	3/8" NPT	Z CKS 12 3/8 NPT	
12	S	1/2" NPT	Z CKS 12 1/2 NPT	
14	S	1/2" NPT	Z CKS 14 1/2 NPT	
16	S	1/2" NPT	Z CKS 16 1/2 NPT	
20	S	3/4" NPT	Z CKS 20 3/4 NPT	
25	S	1" NPT	Z CKS 25 1 NPT	
30	S	1 1/4" NPT	Z CKS 30 1 1/4 NPT	
38	S	1 1/2" NPT	Z CKS 38 1 1/2 NPT	

### Racor en codo orientable BSP-Métrico



Coude orientable mâle BSP - Métrique  
90° Adjustable male stud elbow BSP - Metric  
Raccordo a 90° orientabile maschio BSP - Metrico

T. P.	S.	ROSCA THREAD	REFERENCIA PART N°	€	REFERENCIA STA PART N° STA	€
6	L	1/8" BSP	Z WEE 6L R 1/8		Z STA WEE 6L R 1/8	
8	L	1/4" BSP	Z WEE 8L R 1/4		Z STA WEE 8L R 1/4	
10	L	1/4" BSP	Z WEE 10L R 1/4		Z STA WEE 10L R 1/4	
12	L	3/8" BSP	Z WEE 12L R 3/8		Z STA WEE 12L R 3/8	
15	L	1/2" BSP	Z WEE 15L R 1/2		Z STA WEE 15L R 1/2	
18	L	1/2" BSP	Z WEE 18L R 1/2		Z STA WEE 18L R 1/2	
22	L	3/4" BSP	Z WEE 22L R 3/4		Z STA WEE 22L R 3/4	
16	S	1/2" BSP	Z WEE 16S R 1/2		Z STA WEE 16S R 1/2	
20	S	3/4" BSP	Z WEE 20S R 3/4		Z STA WEE 20S R 3/4	
25	S	1" BSP	Z WEE 25S R 1		Z STA WEE 25S R 1	

## Racores DIN 2353

Raccords à bague DIN 2353  
DIN 2353 Pipe fittings  
Raccordi DIN 2353

### Racor en T rosca cónica BSPT

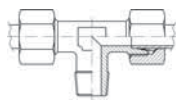

Raccord TÉ mâle gaz conique au centre  
Male stud branch TEE BSP tapered  
Raccordo di estremità a T BSP conico

TUBO PIPE	SERIE	ROSCA THREAD	REFERENCIA PART N°	€
6	L	1/8" BSPT	Z FKL 6 R 1/8	
8	L	1/4" BSPT	Z FKL 8 R 1/4	
10	L	1/4" BSPT	Z FKL 10 R 1/4	
12	L	3/8" BSPT	Z FKL 12 R 3/8	
15	L	1/2" BSPT	Z FKL 15 R 1/2	
18	L	1/2" BSPT	Z FKL 18 R 1/2	
6	S	1/4" BSPT	Z FKS 6 R 1/4	
8	S	1/4" BSPT	Z FKS 8 R 1/4	
10	S	3/8" BSPT	Z FKS 10 R 3/8	
12	S	3/8" BSPT	Z FKS 12 R 3/8	
14	S	1/2" BSPT	Z FKS 14 R 1/2	
16	S	1/4" BSPT	Z FKS 16 1/2	

### Racor en T rosca cónica Métrica

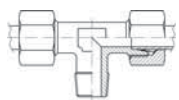

Raccord TÉ mâle Métrique au centre  
Male stud branch TEE Metrical tapered  
Raccordo di estremità a T Metrico conico

TUBO PIPE	SERIE	ROSCA THREAD	REFERENCIA PART N°	€
6	L	M10X1	Z FKL 6 M 10X1	
8	L	M12X1.5	Z FKL 8 M 12X1.5	
10	L	M14X1.5	Z FKL 10 M 14X1.5	
12	L	M16X1.5	Z FKL 12 M 16X1.5	
15	L	M18X1.5	Z FKL 15 M 18X1.5	
18	L	M22X1.5	Z FKL 18 M 22X1.5	
6	S	M12X1.5	Z FKS 6 M 12X1.5	
8	S	M14X1.5	Z FKS 8 M 14X1.5	
10	S	M16X1.5	Z FKS 10 M 16X1.5	
12	S	M18X1.5	Z FKS 12 M 18X1.5	
14	S	M20X1.5	Z FKS 14 M 20X1.5	
16	S	M22X1.5	Z FKS 16 M 22X1.5	

### Racor en T rosca cónica NPT

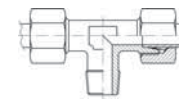

Raccord TÉ mâle NPT au centre  
Male stud branch TEE NPT  
Raccordo di estremità a T NPT

TUBO PIPE	SERIE	ROSCA THREAD	REFERENCIA PART N°	€
6	L	1/8" NPT	Z FKL 6 R 1/8 NPT	
8	L	1/4" NPT	Z FKL 8 R 1/4 NPT	
10	L	1/4" NPT	Z FKL 10 R 1/4 NPT	
12	L	3/8" NPT	Z FKL 12 R 3/8 NPT	
18	L	1/2" NPT	Z FKL 18 R 1/2 NPT	
22	L	3/4" NPT	Z FKL 22 R 3/4 NPT	
28	L	1" NPT	Z FKL 28 R 1 NPT	
35	L	1 1/4" NPT	Z FKL 35 R 1 1/4 NPT	
42	L	1 1/2" NPT	Z FKL 42 R 1 1/2 NPT	
6	S	1/4" NPT	Z FKS 6 R 1/4 NPT	
10	S	3/8" NPT	Z FKS 10 R 3/8 NPT	
12	S	3/8" NPT	Z FKS 12 R 3/8 NPT	
14	S	1/2" NPT	Z FKS 14 R 1/2 NPT	
16	S	1/2" NPT	Z FKS 16 R 1/2 NPT	
20	S	3/4" NPT	Z FKS 20 R 3/4 NPT	
25	S	1" NPT	Z FKS 25 R 1 NPT	
30	S	1 1/4" NPT	Z FKS 30 R 1 1/4 NPT	
38	S	1 1/2" NPT	Z FKS 38 R 1 1/2 NPT	

## Racores DIN 2353

Raccords à bague DIN 2353  
DIN 2353 Pipe fittings  
Raccordi DIN 2353

### Racor en L rosca cónica BSPT

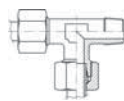

Raccord TÉ mâle gaz conique latéral  
Male stud barrel TEE BSP tapered  
Raccordo di estremità a L BSP conico

TUBO PIPE	SERIE	ROSCA THREAD	REFERENCIA PART N°	€
6	L	1/8" BSPT	<b>Z LKL 6 R 1/8</b>	
8	L	1/4" BSPT	<b>Z LKL 8 R 1/4</b>	
10	L	1/4" BSPT	<b>Z LKL 10 R 1/4</b>	
12	L	3/8" BSPT	<b>Z LKL 12 R 3/8</b>	
15	L	1/2" BSPT	<b>Z LKL 15 R 1/2</b>	
18	L	1/2" BSPT	<b>Z LKL 18 R 1/2</b>	
6	S	1/4" BSPT	<b>Z LKS 6 R 1/4</b>	
8	S	1/4" BSPT	<b>Z LKS 8 R 1/4</b>	
10	S	3/8" BSPT	<b>Z LKS 10 R 3/8</b>	
12	S	3/8" BSPT	<b>Z LKS 12 R 3/8</b>	
14	S	1/2" BSPT	<b>Z LKS 14 R 1/2</b>	
16	S	1/2" BSPT	<b>Z LKS 16 R 1/2</b>	

### Racor en L rosca cónica Métrica

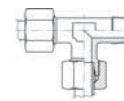

Raccord Té mâle Métrique latéral  
Male stud barrel TEE Metric tapered  
Raccordo di estremità a L Metrico conico

TUBO PIPE	SERIE	ROSCA THREAD	REFERENCIA PART N°	€
6	L	M10X1	<b>Z LKL 6 M 10X1</b>	
8	L	M12X1.5	<b>Z LKL 8 M 12X1.5</b>	
10	L	M14X1.5	<b>Z LKL 10 M 14X1.5</b>	
12	L	M16X1.5	<b>Z LKL 12 M 16X1.5</b>	
15	L	M18X1.5	<b>Z LKL 15 M 18X1.5</b>	
18	L	M22X1.5	<b>Z LKL 18 M 22X1.5</b>	
6	S	M12X1.5	<b>Z LKS 6 M 12X1.5</b>	
8	S	M14X1.5	<b>Z LKS 8 M 14X1.5</b>	
10	S	M16X1.5	<b>Z LKS 10 M 16X1.5</b>	
12	S	M18X1.5	<b>Z LKS 12 M 18X1.5</b>	
14	S	M20X1.5	<b>Z LKS 14 M 20X1.5</b>	
16	S	M22X1.5	<b>Z LKS 16 M 22X1.5</b>	

## Racores DIN 2353

Raccords à bague DIN 2353  
DIN 2353 Pipe fittings  
Raccordi DIN 2353

### Racor de reducción con TL Métrica (serie ligera)



Raccord union simple femelle tournante Métrique (série légère)  
Standpipe reducer with taper (light series)  
Raccordo di riduzione con cono 24° (serie leggera)

TUBO PIPE	S.	REFERENCIA PART N°	€	REFERENCIA PART N°	€
8	6	L Z KORL 8-6 TLM		Z KORL 8-6 CTA	
10	6	L Z KORL 10-6 TLM		Z KORL 10-6 CTA	
12	6	L Z KORL 12-6 TLM			
12	8	L Z KORL 12-8 TLM		Z KORL 12-8 CTA	
12	10	L Z KORL 12-10 TLM		Z KORL 12-10 CTA	
15	6	L Z KORL 15-6 TLM		Z KORL 15-6 CTA	
15	8	L Z KORL 15-8 TLM		Z KORL 15-8 CTA	
15	10	L Z KORL 15-10 TLM		Z KORL 15-10 CTA	
15	12	L Z KORL 15-12 TLM		Z KORL 15-12 CTA	
18	8	L Z KORL 18-8 TLM		Z KORL 18-8 CTA	
18	10	L Z KORL 18-10 TLM		Z KORL 18-10 CTA	
18	12	L Z KORL 18-12 TLM		Z KORL 18-12 CTA	
18	15	L Z KORL 18-15 TLM		Z KORL 18-15 CTA	
22	10	L Z KORL 22-10 TLM			
22	12	L Z KORL 22-12 TLM		Z KORL 22-12 CTA	
22	15	L Z KORL 22-15 TLM		Z KORL 22-15 CTA	
22	18	L Z KORL 22-18 TLM		Z KORL 22-18 CTA	
28	10	L Z KORL 28-10 TLM			
28	12	L Z KORL 28-12 TLM		Z KORL 28-12 CTA	
28	15	L Z KORL 28-15 TLM			
28	18	L Z KORL 28-18 TLM			
28	22	L Z KORL 28-22 TLM			
35	12	L Z KORL 35-12 TLM		Z KORL 35-12 CTA	
35	22	L Z KORL 35-22 TLM			
35	28	L Z KORL 35-28 TLM		Z KORL 35-28 CTA	
42	22	L Z KORL 42-22 TLM		Z KORL 42-22 CTA	
42	28	L Z KORL 42-28 TLM		Z KORL 42-28 CTA	
42	35	L Z KORL 42-35 TLM		Z KORL 42-35 CTA	

Ref.CTA hasta fin de existencias.Salvo indicación expresa del cliente se suministrará TLM o CTA según disponibilidad//Ref.CTA jusqu'à fin du stock.Sauf indication expresse du client, sera fourni TLM ou CTA selon disponibilité//Ref.CTA until end of stock.Unless otherwise indicated by the client, we will supply TLM or CTA depending on availability

### Racor de reducción con TL Métrica (serie pesada)



Raccord union simple femelle tournante Métrique (série lourde)  
Standpipe reducer with taper (heavy series)  
Raccordo di riduzione con cono 24° (serie pesante)

TUBO PIPE	S.	REFERENCIA PART N°	€	REFERENCIA PART N°	€
8	6	S Z KORS 8-6 TLM		Z KORS 8-6 CTA	
10	6	S Z KORS 10-6 TLM		Z KORS 10-6 CTA	
10	8	S Z KORS 10-8 TLM		Z KORS 10-8 CTA	
12	6	S Z KORS 12-6 TLM		Z KORS 12-6 CTA	
12	8	S Z KORS 12-8 TLM		Z KORS 12-8 CTA	
12	10	S Z KORS 12-10 TLM		Z KORS 12-10 CTA	
14	10	S Z KORS 14-10 TLM		Z KORS 14-10 CTA	
14	12	S Z KORS 14-12 TLM			
16	6	S Z KORS 16-6 TLM		Z KORS 16-6 CTA	
16	8	S Z KORS 16-8 TLM		Z KORS 16-8 CTA	
16	10	S Z KORS 16-10 TLM			
16	12	S Z KORS 16-12 TLM		Z KORS 16-12 CTA	
16	14	S Z KORS 16-14 TLM			
20	8	S Z KORS 20-8 TLM		Z KORS 20-8 CTA	
20	10	S Z KORS 20-10 TLM		Z KORS 20-10 CTA	
20	12	S Z KORS 20-12 TLM		Z KORS 20-12 CTA	
20	14	S Z KORS 20-14 TLM			
20	16	S Z KORS 20-16 TLM		Z KORS 20-16 CTA	
25	12	S Z KORS 25-12 TLM		Z KORS 25-12 CTA	
25	16	S Z KORS 25-16 TLM		Z KORS 25-16 CTA	
25	20	S Z KORS 25-20 TLM		Z KORS 25-20 CTA	
30	16	S Z KORS 30-16 TLM			
30	20	S Z KORS 30-20 TLM		Z KORS 30-20 CTA	
30	25	S Z KORS 30-25 TLM		Z KORS 30-25 CTA	
38	20	S Z KORS 38-20 TLM			
38	25	S Z KORS 38-25 TLM		Z KORS 38-25 CTA	
38	30	S Z KORS 38-30 TLM			

Ref.CTA hasta fin de existencias.Salvo indicación expresa del cliente se suministrará TLM o CTA según disponibilidad//Ref.CTA jusqu'à fin du stock.Sauf indication expresse du client, sera fourni TLM ou CTA selon disponibilité//Ref.CTA until end of stock.Unless otherwise indicated by the client, we will supply TLM or CTA depending on availability

## Racores DIN 2353

Raccords à bague DIN 2353  
DIN 2353 Pipe fittings  
Raccordi DIN 2353

### Reducción con rosca M-HF BSP con junta tórica



Raccord réduction mâle gaz-fem gaz avec joint torique

Male-female reducing adaptor BSP cylindrical with o'ring

Adattatore di riduzione filettato maschio - femmina BSP con guarnizione

ROSCA THREAD	REFERENCIA PART N°	€	REFERENCIA PART N°	€
M 1/8" BSP	H 1/4" BSP		Z RI-R 1/8 R 1/4WD	
M 1/4" BSP	H 1/8" BSP		Z RI-R 1/4 R 1/8WD	
M 1/4" BSP	H 3/8" BSP		Z RI-R 1/4 R 3/8WD	
M 1/4" BSP	H 1/2" BSP		Z RI-R 1/4 R 1/2WD	Z RI-R 1/4-1/2
M 3/8" BSP	H 1/8" BSP		Z RI-R 3/8 R 1/8WD	Z RI-R 3/8-1/8
M 3/8" BSP	H 1/4" BSP		Z RI-R 3/8 R 1/4WD	Z RI-R 3/8-1/4
M 3/8" BSP	H 1/2" BSP		Z RI-R 3/8 R 1/2WD	Z RI-R 3/8-1/2
M 3/8" BSP	H 3/4" BSP		Z RI-R 3/8 R 3/4WD	
M 1/2" BSP	H 1/8" BSP		Z RI-R 1/2 R 1/8WD	Z RI-R 1/2-1/8
M 1/2" BSP	H 1/4" BSP		Z RI-R 1/2 R 1/4WD	Z RI-R 1/2-1/4
M 1/2" BSP	H 3/8" BSP		Z RI-R 1/2 R 3/8WD	Z RI-R 1/2-3/8
M 1/2" BSP	H 3/4" BSP		Z RI-R 1/2 R 3/4WD	
M 3/4" BSP	H 1/4" BSP		Z RI-R 3/4 R 1/4WD	Z RI-R 3/4-1/4
M 3/4" BSP	H 3/8" BSP		Z RI-R 3/4 R 3/8WD	Z RI-R 3/4-3/8
M 3/4" BSP	H 1/2" BSP		Z RI-R 3/4 R 1/2WD	Z RI-R 3/4-1/2
M 3/4" BSP	H 1" BSP		Z RI-R 3/4 R 1WD	Z RI-R 3/4-1
M 1" BSP	H 1/4" BSP		Z RI-R 1 R 1/4WD	Z RI-R 1-1/4
M 1" BSP	H 3/8" BSP		Z RI-R 1 R 3/8WD	Z RI-R 1-3/8
M 1" BSP	H 1/2" BSP		Z RI-R 1 R 1/2WD	Z RI-R 1-1/2
M 1" BSP	H 3/4" BSP		Z RI-R 1 R 3/4WD	Z RI-R 1-3/4
M 1" BSP	H 1" BSP		Z RI-R 1 R 1WD	
M 1" 1/4 BSP	H 1/2" BSP		Z RI-R 1 1/4 R 1/2WD	Z RI-R 1 1/4-1/2
M 1" 1/4 BSP	H 3/4" BSP		Z RI-R 1 1/4 R 3/4WD	Z RI-R 1 1/4-3/4
M 1" 1/4 BSP	H 1" BSP		Z RI-R 1 1/4 R 1WD	Z RI-R 1 1/4-1
M 1" 1/4 BSP	F 1" 1/2 BSP		Z RI-R 1 1/4 R 1 1/2WD	Z RI-R 1 1/4-1 1/2
M 1" 1/2 BSP	H 1/2" BSP		Z RI-R 1 1/2 R 1/2WD	
M 1" 1/2 BSP	H 3/4" BSP		Z RI-R 1 1/2 R 3/4WD	
M 1" 1/2 BSP	H 1" BSP		Z RI-R 1 1/2 R 1WD	
M 1" 1/2 BSP	H 1" 1/4 BSP		Z RI-R 1 1/2 R 1 1/4WD	Z RI-R 1 1/2-1 1/4
M 1" 1/2 BSP	F 2" BSP		Z RI-R 1 1/2 R 2WD	Z RI-R 1 1/2-2
M 2" BSP	F 1" 1/2 BSP		Z RI-R 2 R 1 1/2WD	Z RI-R 2-1 1/2

Ref.sin WD hasta fin de existencias.Salvo indicación expresa del cliente se suministrará con o sin junta según disponibilidad//Ref.sans WD jusqu'à fin du stock.Sauf indication expresse du client, sera fourni avec ou sans o'ring selon disponibilité//Ref.without WD until end of stock.Unless otherwise indicated by the client, we will supply with or without o'ring depending on availability

## Racores DIN 2353

Raccords à bague DIN 2353  
DIN 2353 Pipe fittings  
Raccordi DIN 2353

### Racor en codo regulable con tuerca y anillo



Raccord coude orientable tube lisse équipé  
Adjustable stud elbow with nut and ring  
Raccordo orientabile a 90° con dado e anello

T. P.	S.	REFERENCIA PART N°	€	REFERENCIA STA PART N° STA	€
6	L	Z EEL 6 CTA		Z STA EEL 6 CTA	
8	L	Z EEL 8 CTA		Z STA EEL 8 CTA	
10	L	Z EEL 10 CTA		Z STA EEL 10 CTA	
12	L	Z EEL 12 CTA		Z STA EEL 12 CTA	
15	L	Z EEL 15 CTA		Z STA EEL 15 CTA	
18	L	Z EEL 18 CTA		Z STA EEL 18 CTA	
22	L	Z EEL 22 CTA		Z STA EEL 22 CTA	
28	L	Z EEL 28 CTA		Z STA EEL 28 CTA	
35	L	Z EEL 35 CTA		Z STA EEL 35 CTA	
42	L	Z EEL 42 CTA		Z STA EEL 42 CTA	
6	S	Z EES 6 CTA		Z STA EES 6 CTA	
8	S	Z EES 8 CTA		Z STA EES 8 CTA	
10	S	Z EES 10 CTA		Z STA EES 10 CTA	
12	S	Z EES 12 CTA		Z STA EES 12 CTA	
14	S	Z EES 14 CTA		Z STA EES 14 CTA	
16	S	Z EES 16 CTA		Z STA EES 16 CTA	
20	S	Z EES 20 CTA		Z STA EES 20 CTA	
25	S	Z EES 25 CTA		Z STA EES 25 CTA	
30	S	Z EES 30 CTA		Z STA EES 30 CTA	
38	S	Z EES 38 CTA		Z STA EES 38 CTA	

### Racor en T regulable TL Métrica



Raccord TÉ orientable Métrique avec o'ring  
Adjustable stud barrel TEE with o'ring  
Raccordo orientabile a T con o'ring

T. P.	S.	REFERENCIA PART N°	€	REFERENCIA STA PART N° STA	€
6	L	Z TEL 6 TLM		Z STA TEL 6 TLM	
8	L	Z TEL 8 TLM		Z STA TEL 8 TLM	
10	L	Z TEL 10 TLM		Z STA TEL 10 TLM	
12	L	Z TEL 12 TLM		Z STA TEL 12 TLM	
15	L	Z TEL 15 TLM		Z STA TEL 15 TLM	
18	L	Z TEL 18 TLM		Z STA TEL 18 TLM	
22	L	Z TEL 22 TLM		Z STA TEL 22 TLM	
28	L	Z TEL 28 TLM		Z STA TEL 28 TLM	
35	L	Z TEL 35 TLM		Z STA TEL 35 TLM	
42	L	Z TEL 42 TLM		Z STA TEL 42 TLM	
6	S	Z TES 6 TLM		Z STA TES 6 TLM	
8	S	Z TES 8 TLM		Z STA TES 8 TLM	
10	S	Z TES 10 TLM		Z STA TES 10 TLM	
12	S	Z TES 12 TLM		Z STA TES 12 TLM	
14	S	Z TES 14 TLM		Z STA TES 14 TLM	
16	S	Z TES 16 TLM		Z STA TES 16 TLM	
20	S	Z TES 20 TLM		Z STA TES 20 TLM	
25	S	Z TES 25 TLM		Z STA TES 25 TLM	
30	S	Z TES 30 TLM		Z STA TES 30 TLM	
38	S	Z TES 38 TLM		Z STA TES 38 TLM	

### Racor en codo regulable TL Métrica



Raccord coude orientable Métrique avec o'ring  
Adjustable stud elbow with o'ring  
Raccordo orientabile a 90° con o'ring

T. P.	S.	REFERENCIA PART N°	€	REFERENCIA STA PART N° STA	€
6	L	Z EEL 6 TLM		Z STA EEL 6 TLM	
8	L	Z EEL 8 TLM		Z STA EEL 8 TLM	
10	L	Z EEL 10 TLM		Z STA EEL 10 TLM	
12	L	Z EEL 12 TLM		Z STA EEL 12 TLM	
15	L	Z EEL 15 TLM		Z STA EEL 15 TLM	
18	L	Z EEL 18 TLM		Z STA EEL 18 TLM	
22	L	Z EEL 22 TLM		Z STA EEL 22 TLM	
28	L	Z EEL 28 TLM		Z STA EEL 28 TLM	
35	L	Z EEL 35 TLM		Z STA EEL 35 TLM	
42	L	Z EEL 42 TLM		Z STA EEL 42 TLM	
6	S	Z EES 6 TLM		Z STA EES 6 TLM	
8	S	Z EES 8 TLM		Z STA EES 8 TLM	
10	S	Z EES 10 TLM		Z STA EES 10 TLM	
12	S	Z EES 12 TLM		Z STA EES 12 TLM	
14	S	Z EES 14 TLM		Z STA EES 14 TLM	
16	S	Z EES 16 TLM		Z STA EES 16 TLM	
20	S	Z EES 20 TLM		Z STA EES 20 TLM	
25	S	Z EES 25 TLM		Z STA EES 25 TLM	
30	S	Z EES 30 TLM		Z STA EES 30 TLM	
38	S	Z EES 38 TLM		Z STA EES 38 TLM	

### Racor en L regulable TL Métrica



Raccord L orientable renversé Métrique avec o'ring  
Adjustable stud barrel L with o'ring  
Raccordo orientabile a L con o'ring

T. P.	S.	ROSCA THREAD	REFERENCIA PART N°	€	REFERENCIA STA PART N° STA	€
6	L	M12X1.5	Z LEL 6 TLM		Z STA LEL 6 TLM	
8	L	M14X1.5	Z LEL 8 TLM		Z STA LEL 8 TLM	
10	L	M16X1.5	Z LEL 10 TLM		Z STA LEL 10 TLM	
12	L	M18X1.5	Z LEL 12 TLM		Z STA LEL 12 TLM	
15	L	M22X1.5	Z LEL 15 TLM		Z STA LEL 15 TLM	
18	L	M26X1.5	Z LEL 18 TLM		Z STA LEL 18 TLM	
22	L	M30X2	Z LEL 22 TLM		Z STA LEL 22 TLM	
28	L	M36X2	Z LEL 28 TLM		Z STA LEL 28 TLM	
35	L	M45X2	Z LEL 35 TLM		Z STA LEL 35 TLM	
42	L	M52X2	Z LEL 42 TLM		Z STA LEL 42 TLM	
6	S	M14X1.5	Z LES 6 TLM		Z STA LES 6 TLM	
8	S	M16X1.5	Z LES 8 TLM		Z STA LES 8 TLM	
10	S	M18X1.5	Z LES 10 TLM		Z STA LES 10 TLM	
12	S	M20X1.5	Z LES 12 TLM		Z STA LES 12 TLM	
14	S	M22X1.5	Z LES 14 TLM		Z STA LES 14 TLM	
16	S	M24X1.5	Z LES 16 TLM		Z STA LES 16 TLM	
20	S	M30X2	Z LES 20 TLM		Z STA LES 20 TLM	
25	S	M36X2	Z LES 25 TLM		Z STA LES 25 TLM	
30	S	M42X2	Z LES 30 TLM		Z STA LES 30 TLM	
38	S	M52X2	Z LES 38 TLM		Z STA LES 38 TLM	

# Racores DIN 2353

Raccords à bague DIN 2353  
DIN 2353 Pipe fittings  
Raccordi DIN 2353

## Racor unión TL Métrica

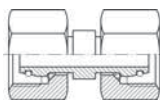

Raccord union tournante Métrique égale

Straight connection with o'ring

Raccordo di estremità diritto Metrico con o'ring

TUBO PIPE	SERIE	REFERENCIA PART N°	€
6	L	Z ATL 6	
8	L	Z ATL 8	
10	L	Z ATL 10	
12	L	Z ATL 12	
15	L	Z ATL 15	
18	L	Z ATL 18	
22	L	Z ATL 22	
28	L	Z ATL 28	
35	L	Z ATL 35	
42	L	Z ATL 42	
6	S	Z ATS 6	
8	S	Z ATS 8	
10	S	Z ATS 10	
12	S	Z ATS 12	
14	S	Z ATS 14	
16	S	Z ATS 16	
20	S	Z ATS 20	
25	S	Z ATS 25	
30	S	Z ATS 30	
38	S	Z ATS 38	

## Racor recto macho NPT - TL Métrica

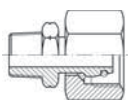

Raccord adapteur tube lisse - mâle NPT- fem. tourn. métrique

Straight stud standpipe adaptor NPT+metric swivel fem.

Adattatore diritto NPT - tubo TLM

TUBO PIPE	SERIE	ROSCA THREAD	REFERENCIA PART N°	€
6	L	1/8"NPT	Z RAL 6 R 1/8 NPTTLM	
8	L	1/4"NPT	Z RAL 8 R 1/4 NPTTLM	
10	L	1/4"NPT	Z RAL 10 R 1/4 NPTTLM	
12	L	3/8" NPT	Z RAL 12 R 3/8 NPTTLM	
15	L	1/2" NPT	Z RAL 15 R 1/2 NPTTLM	
18	L	1/2"NPT	Z RAL 18 R 1/2 NPTTLM	
22	L	3/4"NPT	Z RAL 22 R 3/4 NPTTLM	
28	L	1"NPT	Z RAL 28 R 1 NPTTLM	
35	L	1 1/4 NPT	Z RAL 35 R 1 1/4 NPTTLM	
42	L	1 1/2 NPT	Z RAL 42 R 1 1/2 NPTTLM	
6	S	1/4"NPT	Z RAS 6 R 1/4 NPTTLM	
8	S	1/4"NPT	Z RAS 8 R 1/4 NPTTLM	
10	S	3/8" NPT	Z RAS 10 R 3/8 NPTTLM	
12	S	1/4" NPT	Z RAS 12 R 1/4 NPTTLM	
12	S	3/8" NPT	Z RAS 12 R 3/8 NPTTLM	
14	S	1/2"NPT	Z RAS 14 R 1/2 NPTTLM	
16	S	1/2"NPT	Z RAS 16 R 1/2 NPTTLM	
20	S	3/4"NPT	Z RAS 20 R 3/4 NPTTLM	
25	S	3/4"NPT	Z RAS 25 R 3/4 NPTTLM	
25	S	1"NPT	Z RAS 25 R 1 NPTTLM	
30	S	1"NPT	Z RAS 30 R 1 NPTTLM	
30	S	1 1/4 NPT	Z RAS 30 R 1 1/4 NPTTLM	
38	S	1 1/2 NPT	Z RAS 38 R 1 1/2 NPTTLM	

## Racor recto macho BSP con junta plana - TLM



Raccord adapt.tube lisse-mâle gaz BSP avec joint plat-fem.tourn.métrique

Straight stud standpipe adaptor with captive seal BSP cylindrical-metric swivel fem.

Adattatore diritto BSP cilindrico con guarnizione ed o'ring

T. P.	S.	ROSCA THREAD	REFERENCIA PART N°	€	REFERENCIA PART N°	€
6	L	1/8"BSP	Z RAL 6 R 1/8TLMWD			
8	L	1/4"BSP	Z RAL 8 R 1/4TLMWD		Z RAL 8 R 1/4CTA	
10	L	1/4"BSP	Z RAL 10 R 1/4TLMWD		Z RAL 10 R 1/4CTA	
12	L	1/4"BSP	Z RAL 12 R 1/4TLMWD		Z RAL 12 R 1/4CTA	
12	L	3/8"BSP	Z RAL 12 R 3/8TLMWD		Z RAL 12 R 3/8CTA	
12	L	1/2"BSP	Z RAL 12 R 1/2TLMWD		Z RAL 12 R 1/2CTA	
15	L	1/2"BSP	Z RAL 15 R 1/2TLMWD		Z RAL 15 R 1/2CTA	
18	L	1/2"BSP	Z RAL 18 R 1/2TLMWD		Z RAL 18 R 1/2CTA	
22	L	1/2"BSP	Z RAL 22 R 1/2TLMWD		Z RAL 22 R 1/2CTA	
22	L	3/4"BSP	Z RAL 22 R 3/4TLMWD		Z RAL 22 R 3/4CTA	
28	L	1"BSP	Z RAL 28 R 1TLMWD		Z RAL 28 R 1CTA	
35	L	1 1/4 BSP	Z RAL 35 R 1 1/4TLMWD		Z RAL 35 R 1 1/4CTA	
42	L	1 1/2 BSP	Z RAL 42 R 1 1/2TLMWD		Z RAL 42 R 1 1/2CTA	
6	S	1/4"BSP	Z RAS 6 R 1/4TLMWD			
8	S	1/4"BSP	Z RAS 8 R 1/4TLMWD		Z RAS 8 R 1/4CTA	
10	S	3/8"BSP	Z RAS 10 R 3/8TLMWD		Z RAS 10 R 3/8CTA	
12	S	3/8"BSP	Z RAS 12 R 3/8TLMWD		Z RAS 12 R 3/8CTA	
14	S	1/2"BSP	Z RAS 14 R 1/2TLMWD			
16	S	1/2"BSP	Z RAS 16 R 1/2TLMWD		Z RAS 16 R 1/2CTA	
20	S	3/4"BSP	Z RAS 20 R 3/4TLMWD		Z RAS 20 R 3/4CTA	
25	S	1"BSP	Z RAS 25 R 1TLMWD		Z RAS 25 R 1CTA	
30	S	1 1/4 BSP	Z RAS 30 R 1 1/4TLMWD		Z RAS 30 R 1 1/4CTA	
38	S	1 1/2 BSP	Z RAS 38 R 1 1/2TLMWD		Z RAS 38 R 1 1/2CTA	

Ref.CTA hasta fin de existencias.Salvo indicación expresa del cliente se suministrará TLM o CTA según disponibilidad//Ref.CTA jusqu'à fin du stock.Sauf indication expresse du client, sera fourni TLM ou CTA selon disponibilité//Ref.CTA until end of stock.Unless otherwise indicated by the client, we will supply TLM or CTA depending on availability

## Racor recto macho Métrico con junta plana - tubo TLM

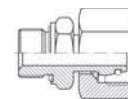

Raccord adapt.tube lisse-mâle Métrique avec joint plat-fem.tourn.métrique

Straight stud standpipe adaptor Metric with captive seal-metric swivel fem.

Adattatore diritto Metrico cilindrico con guarnizione - tubo TLM

TUBO PIPE	SERIE	ROSCA THREAD	REFERENCIA PART N°	€
6	L	M10X1	Z RAL 6M10X1TLMWD	
8	L	M12X1.5	Z RAL 8M12X1.5TLMWD	
10	L	M14X1.5	Z RAL 10M14X1.5TLMWD	
12	L	M16X1.5	Z RAL 12M16X1.5TLMWD	
15	L	M18X1.5	Z RAL 15M18X1.5TLMWD	
18	L	M22X1.5	Z RAL 18M22X1.5TLMWD	
22	L	M26X1.5	Z RAL 22M26X1.5TLMWD	
28	L	M33X2	Z RAL 28M33X2TLMWD	
35	L	M42X2	Z RAL 35M42X2TLMWD	
42	L	M48X2	Z RAL 42M48X2TLMWD	
6	S	M12X1.5	Z RAS 6M12X1.5TLMWD	
8	S	M14X1.5	Z RAS 8M14X1.5TLMWD	
10	S	M16X1.5	Z RAS 10M16X1.5TLMWD	
12	S	M18X1.5	Z RAS 12M18X1.5TLMWD	
14	S	M20X1.5	Z RAS 14M20X1.5TLMWD	
16	S	M22X1.5	Z RAS 16M22X1.5TLMWD	
20	S	M27X2	Z RAS 20M27X2TLMWD	
25	S	M33X2	Z RAS 25M33X2TLMWD	
30	S	M42X2	Z RAS 30M42X2TLMWD	
38	S	M48X2	Z RAS 38M48X2TLMWD	

## Racores DIN 2353

Raccords à bague DIN 2353  
DIN 2353 Pipe fittings  
Raccordi DIN 2353

### Racor recto para soldar

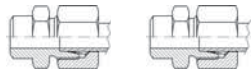

Raccord mamelon hexagonal Métrique à souder  
Weldable straight coupling  
Raccordo diritto a saldare

TUBO PIPE	SERIE	REFERENCIA PART N°	€	REFERENCIA STA PART N° STA	€
6	L	Z ASL 6		Z STA ASL 6	
8	L	Z ASL 8		Z STA ASL 8	
10	L	Z ASL 10		Z STA ASL 10	
12	L	Z ASL 12		Z STA ASL 12	
15	L	Z ASL 15		Z STA ASL 15	
18	L	Z ASL 18		Z STA ASL 18	
22	L	Z ASL 22		Z STA ASL 22	
28	L	Z ASL 28		Z STA ASL 28	
35	L	Z ASL 35		Z STA ASL 35	
42	L	Z ASL 42		Z STA ASL 42	
6	S	Z ASS 6		Z STA ASS 6	
8	S	Z ASS 8		Z STA ASS 8	
10	S	Z ASS 10		Z STA ASS 10	
12	S	Z ASS 12		Z STA ASS 12	
14	S	Z ASS 14			
16	S	Z ASS 16		Z STA ASS 16	
20	S	Z ASS 20		Z STA ASS 20	
25	S	Z ASS 25		Z STA ASS 25	
30	S	Z ASS 30		Z STA ASS 30	
38	S	Z ASS 38		Z STA ASS 38	

### Racor pasatabique para soldar

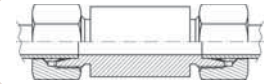

Raccord union double passe cloison Métrique à souder  
Weldable bulkhead coupling  
Raccordo passaparete a saldare

TUBO PIPE	SERIE	REFERENCIA PART N°	€
6	L	Z ESVL 6	
8	L	Z ESVL 8	
10	L	Z ESVL 10	
12	L	Z ESVL 12	
15	L	Z ESVL 15	
18	L	Z ESVL 18	
22	L	Z ESVL 22	
28	L	Z ESVL 28	
35	L	Z ESVL 35	
42	L	Z ESVL 42	
6	S	Z ESVS 6	
8	S	Z ESVS 8	
10	S	Z ESVS 10	
12	S	Z ESVS 12	
14	S	Z ESVS 14	
16	S	Z ESVS 16	
20	S	Z ESVS 20	
25	S	Z ESVS 25	
30	S	Z ESVS 30	
38	S	Z ESVS 38	

### Boquilla para soldar

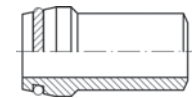

Raccord collet cône métrique à souder  
Welding nipple with o-ring  
Ogiva a saldare con o'ring

TUBO PIPE	SERIE	REFERENCIA PART N°	€
10x1.5	L	Z ORIL 10	
15x2.5	L	Z ORIL 15	
18x2.5	L	Z ORIL 18	
22x2.5	L	Z ORIL 22	
28x3	L	Z ORIL 28	
35x4	L	Z ORIL 35	
42x3	L	Z ORIL 42	
6x1.5	S	Z ORIS 6	
8x2	S	Z ORIS 8	
10x2	S	Z ORIS 10	
12x2	S	Z ORIS 12	
14x3	S	Z ORIS 14	
16x3	S	Z ORIS 16	
20x3	S	Z ORIS 20	
25x3.5	S	Z ORIS 25	
30x5	S	Z ORIS 30	
38x5	S	Z ORIS 38	



## Racores DIN 2353

Raccords à bague DIN 2353  
DIN 2353 Pipe fittings  
Raccordi DIN 2353

### Racor recto pasatabique con tuerca

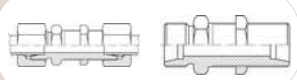

Raccord droit union double passe cloison avec écrou  
Straight bulkhead coupling  
Raccordo passaparete

TUBO PIPE	SERIE	REFERENCIA PART N°	€	REFERENCIA STA PART N° STA	€
6	L	Z SVL 6		Z STA SVL 6	
8	L	Z SVL 8		Z STA SVL 8	
10	L	Z SVL 10		Z STA SVL 10	
12	L	Z SVL 12		Z STA SVL 12	
15	L	Z SVL 15		Z STA SVL 15	
18	L	Z SVL 18		Z STA SVL 18	
22	L	Z SVL 22		Z STA SVL 22	
28	L	Z SVL 28			
35	L	Z SVL 35			
42	L	Z SVL 42			
6	S	Z SVS 6		Z STA SVS 6	
8	S	Z SVS 8		Z STA SVS 8	
10	S	Z SVS 10		Z STA SVS 10	
12	S	Z SVS 12		Z STA SVS 12	
14	S	Z SVS 14		Z STA SVS 14	
16	S	Z SVS 16		Z STA SVS 16	
20	S	Z SVS 20		Z STA SVS 20	
25	S	Z SVS 25		Z STA SVS 25	
30	S	Z SVS 30			
38	S	Z SVS 38			

### Racor en codo pasatabique con tuerca

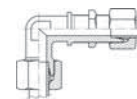

Raccord coude égal passe cloison  
Elbow bulkhead coupling  
Raccordo passaparete a 90°

TUBO PIPE	SERIE	REFERENCIA PART N°	€
6	17	L	Z USVL 6
8	19	L	Z USVL 8
10	22	L	Z USVL 10
12	24	L	Z USVL 12
15	27	L	Z USVL 15
18	32	L	Z USVL 18
22	36	L	Z USVL 22
28	42	L	Z USVL 28
35	50	L	Z USVL 35
42	60	L	Z USVL 42
6	19	S	Z USVS 6
8	22	S	Z USVS 8
10	24	S	Z USVS 10
12	27	S	Z USVS 12
14	27	S	Z USVS 14
16	30	S	Z USVS 16
20	36	S	Z USVS 20
25	42	S	Z USVS 25
30	50	S	Z USVS 30
38	60	S	Z USVS 38

### Tuerca pasatabique Métrica



Écrou Métrique passe cloison  
Metric nut bulkhead  
Dado passaparete Metrico

TUBO PIPE	ROSCA THREAD	REFERENCIA PART N°	€
6L	M12x1.5	KZTPM12	
8L / 6S	M14x1.5	KZTPM14	
10L / 8S	M16x1.5	KZTPM16	
12L / 10S	M18x1.5	KZTPM18	
12S	M20x1.5	KZTPM20	
15L / 14S	M22x1.5	KZTPM22	
16S	M24x1.5	KZTPM24	
18L	M26x1.5	KZTPM26	
22L / 20S	M30x2	KZTPM30	
28L / 25S	M36x2	KZTPM36	
30S	M42x2	KZTPM42	
35L	M45x2	KZTPM45	
42L / 38S	M52x2	KZTPM52	

# Racores DIN 2353

Raccords à bague DIN 2353  
DIN 2353 Pipe fittings  
Raccordi DIN 2353

## Racor recto hembra rosca BSP



Raccord union simple femelle gaz  
Female stud coupling  
Raccordo diritto femmina BSP

T. P.	S.	ROSCA THREAD	REFERENCIA PART N°	€	REFERENCIA STA PART N° STA	€
6	L	1/8" BSP	Z GAIL 6 R 1/8		Z STA GAIL 6 R 1/8	
6	L	1/4" BSP	Z GAIL 6 R 1/4		Z STA GAIL 6 R 1/4	
8	L	1/4" BSP	Z GAIL 8 R 1/4		Z STA GAIL 8 R 1/4	
10	L	1/4" BSP	Z GAIL 10 R 1/4		Z STA GAIL 10 R 1/4	
12	L	1/2" BSP	Z GAIL 12 R 1/2			
12	L	3/8" BSP	Z GAIL 12 R 3/8		Z STA GAIL 12 R 3/8	
15	L	1/2" BSP	Z GAIL 15 R 1/2		Z STA GAIL 15 R 1/2	
18	L	1/2" BSP	Z GAIL 18 R 1/2		Z STA GAIL 18 R 1/2	
22	L	3/4" BSP	Z GAIL 22 R 3/4		Z STA GAIL 22 R 3/4	
28	L	1" BSP	Z GAIL 28 R 1			
35	L	1 1/4" BSP	Z GAIL 35 R 1 1/4			
42	L	1 1/2" BSP	Z GAIL 42 R 1 1/2			
6	S	1/4" BSP	Z GAIS 6 R 1/4		Z STA GAIS 6 R 1/4	
8	S	1/4" BSP	Z GAIS 8 R 1/4		Z STA GAIS 8 R 1/4	
10	S	3/8" BSP	Z GAIS 10 R 3/8		Z STA GAIS 10 R 3/8	
12	S	3/8" BSP	Z GAIS 12 R 3/8		Z STA GAIS 12 R 3/8	
14	S	3/8" BSP	Z GAIS 14 R 3/8			
14	S	1/2" BSP	Z GAIS 14 R 1/2		Z STA GAIS 14 R 1/2	
16	S	1/2" BSP	Z GAIS 16 R 1/2		Z STA GAIS 16 R 1/2	
20	S	3/4" BSP	Z GAIS 20 R 3/4			
25	S	1" BSP	Z GAIS 25 R 1		Z STA GAIS 25 R 1	
30	S	1 1/4" BSP	Z GAIS 30 R 1 1/4			
38	S	1 1/2" BSP	Z GAIS 38 R 1 1/2			

## Racor recto hembra rosca Métrica

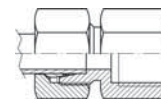

Raccord union simple femelle Métrique  
Female stud coupling Metric Cylindrical  
Raccordo diritto femmina Metrico

TUBO PIPE	SERIE	ROSCA THREAD	REFERENCIA PART N°	€
6	L	M10X1	Z GAIL 6 M 10X1	
8	L	M12X1.5	Z GAIL 8 M 12X1.5	
10	L	M14X1.5	Z GAIL 10 M 14X1.5	
12	L	M16X1.5	Z GAIL 12 M 16X1.5	
15	L	M18X1.5	Z GAIL 15 M 18X1.5	
18	L	M22X1.5	Z GAIL 18 M 22X1.5	
22	L	M26X1.5	Z GAIL 22 M 26X1.5	
28	L	M33X2	Z GAIL 28 M 33X2	
35	L	M42X2	Z GAIL 35 M 42X2	
42	L	M48X2	Z GAIL 42 M 48X2	
6	S	M12X1.5	Z GAIS 6 M 12X1.5	
8	S	M14X1.5	Z GAIS 8 M 14X1.5	
10	S	M16X1.5	Z GAIS 10 M 16X1.5	
12	S	M18X1.5	Z GAIS 12 M 18X1.5	
14	S	M20X1.5	Z GAIS 14 M 20X1.5	
16	S	M22X1.5	Z GAIS 16 M 22X1.5	
20	S	M27X2	Z GAIS 20 M 27X2	
25	S	M33X2	Z GAIS 25 M 33X2	
30	S	M42X2	Z GAIS 30 M 42X2	
38	S	M48X2	Z GAIS 38 M 48X2	

## Racor para manómetro BSP

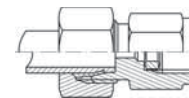

Raccord union pour manomètre gaz  
Gauge coupling BSP cylindrical  
Raccordo per manometro BSP

TUBO PIPE	SERIE	ROSCA THREAD	REFERENCIA PART N°	€
6	L	1/4" BSP	Z MAVL 6 R 1/4	
8	L	1/4" BSP	Z MAVL 8 R 1/4	
10	L	1/4" BSP	Z MAVL 10 R 1/4	
12	L	1/4" BSP	Z MAVL 12 R 1/4	
6	S	1/2" BSP	Z MAVS 6 R 1/2	
8	S	1/2" BSP	Z MAVS 8 R 1/2	
10	S	1/2" BSP	Z MAVS 10 R 1/2	
12	S	1/2" BSP	Z MAVS 12 R 1/2	

## Arandela para manómetros



Raccord bague pour manomètres  
Seal for gauge coupling  
Guarnizione per manometro

ROSCA THREAD	REFERENCIA PART N°	€
R 1/4" BSP	Z AM 6	
R 1/2" BSP	Z AM 12	

## Racores DIN 2353

Raccords à bague DIN 2353  
DIN 2353 Pipe fittings  
Raccordi DIN 2353

### Racor en codo orientable sin estrangulación rosca BSP



Raccord équerre orientable articulée sans étranglement gaz  
Banjo coupling with captive seal and o'ring BSP cylindrical  
Raccordo orientabile 90° ad occhio BSP con guarnizione

T. P.	S.	ROSCA THREAD	REFERENCIA PART N°	€	REFERENCIA STA PART N° STA	€
6	L	1/8" BSP	Z WSVL 6 R 1/8		Z STA WSVL 6 R 1/8	
8	L	1/4" BSP	Z WSVL 8 R 1/4		Z STA WSVL 8 R 1/4	
10	L	1/4" BSP	Z WSVL 10 R 1/4		Z STA WSVL 10 R 1/4	
12	L	3/8" BSP	Z WSVL 12 R 3/8		Z STA WSVL 12 R 3/8	
15	L	1/2" BSP	Z WSVL 15 R 1/2		Z STA WSVL 15 R 1/2	
18	L	1/2" BSP	Z WSVL 18 R 1/2		Z STA WSVL 18 R 1/2	
22	L	3/4" BSP	Z WSVL 22 R 3/4		Z STA WSVL 22 R 3/4	
28	L	1" BSP	Z WSVL 28 R 1			
35	L	1"1/4 BSP	Z WSVL 35 R 1 1/4			
42	L	1"1/2 BSP	Z WSVL 42 R 1 1/2			
6	S	1/4" BSP	Z WSVS 6 R 1/4		Z STA WSVS 6 R 1/4	
8	S	1/4" BSP	Z WSVS 8 R 1/4		Z STA WSVS 8 R 1/4	
10	S	3/8" BSP	Z WSVS 10 R 3/8		Z STA WSVS 10 R 3/8	
12	S	3/8" BSP	Z WSVS 12 R 3/8		Z STA WSVS 12 R 3/8	
14	S	1/2" BSP	Z WSVS 14 R 1/2		Z STA WSVS 14 R 1/2	
16	S	1/2" BSP	Z WSVS 16 R 1/2		Z STA WSVS 16 R 1/2	
20	S	3/4" BSP	Z WSVS 20 R 3/4		Z STA WSVS 20 R 3/4	
25	S	1" BSP	Z WSVS 25 R 1			
30	S	1"1/4 BSP	Z WSVS 30 R 1 1/4			
38	S	1"1/2 BSP	Z WSVS 38 R 1 1/2			

### Racor en codo orientable sin estrangulación rosca Métrica



Raccord équerre orientable articulée sans étranglement Métrique  
Banjo coupling with captive seal and o'ring Metric cylindrical  
Raccordo orientabile 90° ad occhio Metrico con guarnizione

T. P.	S.	R. T.	REFERENCIA PART N°	€	REFERENCIA STA PART N° STA	€
6	L	M10X1	Z WSVL 6 M 10X1		Z STA WSVL 6 M 10X1	
8	L	M12X1.5	Z WSVL 8 M 12X1,5		Z STA WSVL 8 M 12X1,5	
10	L	M14X1.5	Z WSVL 10 M 14X1,5		Z STA WSVL 10 M 14X1,5	
12	L	M16X1.5	Z WSVL 12 M 16X1,5		Z STA WSVL 12 M 16X1,5	
15	L	M18X1.5	Z WSVL 15 M 18X1,5		Z STA WSVL 15 M 18X1,5	
18	L	M22X1.5	Z WSVL 18 M 22X1,5		Z STA WSVL 18 M 22X1,5	
22	L	M26X1.5	Z WSVL 22 M 26X1,5			
28	L	M33X2	Z WSVL 28 M 33X2			
35	L	M42X2	Z WSVL 35 M 42X2			
42	L	M48X2	Z WSVL 42 M 48X2			
6	S	M12X1.5	Z WSVS 6 M 12X1,5		Z STA WSVS 6 M 12X1,5	
8	S	M14X1.5	Z WSVS 8 M 14X1,5		Z STA WSVS 8 M 14X1,5	
10	S	M16X1.5	Z WSVS 10 M 16X1,5		Z STA WSVS 10 M 16X1,5	
12	S	M18X1.5	Z WSVS 12 M 18X1,5		Z STA WSVS 12 M 18X1,5	
14	S	M20X1.5	Z WSVS 14 M 20X1,5			
16	S	M22X1.5	Z WSVS 16 M 22X1,5		Z STA WSVS 16 M 22X1,5	
20	S	M27X2	Z WSVS 20 M 27X2		Z STA WSVS 20 M 27X2	
30	S	M42X2	Z WSVS 30 M 42X2			
38	S	M48X2	Z WSVS 38 M 48X2			

## Racores DIN 2353

Raccords à bague DIN 2353  
DIN 2353 Pipe fittings  
Raccordi DIN 2353

### Tapón de cierre para tubo con junta tórica

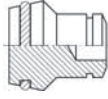

Raccord bouchon de fermeture avec o'ring

Blanking plug with o'ring

Tappo di chiusura con o'ring

TUBO PIPE	SERIE	REFERENCIA PART N°	€
6	L	Z BUTZEN L 6	
8	L	Z BUTZEN L 8	
10	L	Z BUTZEN L 10	
12	L	Z BUTZEN L 12	
15	L	Z BUTZEN L 15	
18	L	Z BUTZEN L 18	
22	L	Z BUTZEN L 22	
28	L	Z BUTZEN L 28	
35	L	Z BUTZEN L 35	
42	L	Z BUTZEN L 42	
14	S	Z BUTZEN S 14	
16	S	Z BUTZEN S 16	
20	S	Z BUTZEN S 20	
25	S	Z BUTZEN S 25	
30	S	Z BUTZEN S 30	
38	S	Z BUTZEN S 38	

### Tapón de cierre Allen rosca BSP con junta

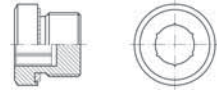

Raccord bouchon Allen gaz avec joint plat

Blanking plug with captive seal BSP cylindrical

Tappo cilindrico BSP esagono incassato con guarnizione

ROSCA THREAD	REFERENCIA PART N°	€
1/8" BSP	Z STOPFEN 1/8	
1/4" BSP	Z STOPFEN 1/4	
3/8" BSP	Z STOPFEN 3/8	
1/2" BSP	Z STOPFEN 1/2	
3/4" BSP	Z STOPFEN 3/4	
1" BSP	Z STOPFEN 1	
1"1/4 BSP	Z STOPFEN 1 1/4	
1"1/2 BSP	Z STOPFEN 1 1/2	

### Tapón de cierre Allen rosca Métrica con junta

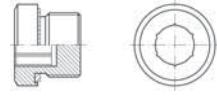

Raccord bouchon Allen Métrique avec joint plat

Blanking plug with captive seal Métric cylindrical

Tappo cilindrico Metrico esagono incassato con guarnizione

ROSCA THREAD	REFERENCIA PART N°	€
M10X1	Z STOPFEN M 10X1	
M12X1.5	Z STOPFEN M 12X1,5	
M14X1.5	Z STOPFEN M 14X1,5	
M16X1.5	Z STOPFEN M 16X1,5	
M18X1.5	Z STOPFEN M 18X1,5	
M20X1.5	Z STOPFEN M 20X1,5	
M22X1.5	Z STOPFEN M 22X1,5	
M26X1.5	Z STOPFEN M 26X1,5	
M27X2	Z STOPFEN M 27X2	
M33X2	Z STOPFEN M 33X2	
M42X2	Z STOPFEN M 42X2	
M48X2	Z STOPFEN M 48X2	

# Racores DIN 2353

Raccords à bague DIN 2353  
DIN 2353 Pipe fittings  
Raccordi DIN 2353

## Juntas tóricas FKM verde



Joint torique en FKM vert  
Green FKM o-ring  
Guarnizioni o'Rings FKM verde

TUBO PIPE	REFERENCIA PART N°	€
6	JVT06	
8	JVT08	
10	JVT10	
12	JVT12	
14	JVT14	
15-16	JVT15	
18	JVT18	
20	JVT20	
22	JVT22	
25	JVT25	
28	JVT28	
30	JVT30	
35	JVT35	
38	JVT38	
42	JVT42	

## Juntas planas FKM verde



Joint plat en FKM vert  
Green FKM captive seal  
Guarnizioni piatte FKM verde

ROSCA THREAD	REFERENCIA PART N°	€
1/8" BSP - M10x1	JVBSP02	
M12x1.5	JVM12	
1/4" BSP - M14x1.5	JVBSP04	
3/8" BSP - M16x1.5	JVBSP06	
1/2" BSP	JVBSP08	
M18x1.5	JVM18	
M20x1.5	JVM20	
M22x1.5	JVM22	
3/4" BSP - M26x1.5	JVBSP12	
1" BSP - M33x2	JVBSP16	
1"1/4 BSP - M42x2	JVBSP20	
1"1/2 BSP - M48x2	JVBSP24	
2" BSP	JVBSP32	

## Vomo

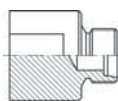

Outil  
Tool  
Atrezzo

TUBO PIPE	SERIE	REFERENCIA PART N°	€
6	L	Z VOMO L 6	
8	L	Z VOMO L 8	
10	L	Z VOMO L 10	
12	L	Z VOMO L 12	
15	L	Z VOMO L 15	
18	L	Z VOMO L 18	
22	L	Z VOMO L 22	
28	L	Z VOMO L 28	
35	L	Z VOMO L 35	
42	L	Z VOMO L 42	
6	S	Z VOMO S 6	
8	S	Z VOMO S 8	
10	S	Z VOMO S 10	
12	S	Z VOMO S 12	
14	S	Z VOMO S 14	
16	S	Z VOMO S 16	
20	S	Z VOMO S 20	
25	S	Z VOMO S 25	
30	S	Z VOMO S 30	
38	S	Z VOMO S 38	

Material Acero Templado//Matériel Acier Trempé//Made of Hardened tool-steel//  
Materiale acciaio temprato

## Grasa



Graisse  
Grease  
Lubrificante

Descripción Description	REFERENCIA PART N°	€
Grasa para montaje	GR ASW120	

## Racores DIN 2353

Raccords à bague DIN 2353  
DIN 2353 Pipe fittings  
Raccordi DIN 2353

### Válvula antirretorno rosca BSP-tubo

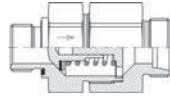

Clapet anti-rétour unidirectionnel à gauche mâle-tube  
Non-return valve flow from male stud end BSP cylindrical  
Valvola di ritegno a sinistra

TUBO PIPE	SERIE	ROSCA THREAD	REFERENCIA PART N°	€
6	L	M 1/8" BSP	Z RHVL 6 R 1/8	
8	L	M 1/4" BSP	Z RHVL 8 R 1/4	
10	L	M 1/4" BSP	Z RHVL 10 R 1/4	
12	L	M 3/8" BSP	Z RHVL 12 R 3/8	
15	L	M 1/2" BSP	Z RHVL 15 R 1/2	
18	L	M 1/2" BSP	Z RHVL 18 R 1/2	
22	L	M 3/4" BSP	Z RHVL 22 R 3/4	
28	L	M 1" BSP	Z RHVL 28 R 1	
35	L	M 1"1/4 BSP	Z RHVL 35 R 1 1/4	
42	L	M 1"1/2 BSP	Z RHVL 42 R 1 1/2	
6	S	M 1/4" BSP	Z RHVS 6 R 1/4	
8	S	M 1/4" BSP	Z RHVS 8 R 1/4	
10	S	M 3/8" BSP	Z RHVS 10 R 3/8	
12	S	M 3/8" BSP	Z RHVS 12 R 3/8	
14	S	M 1/2" BSP	Z RHVS 14 R 1/2	
16	S	M 1/2" BSP	Z RHVS 16 R 1/2	
20	S	M 3/4" BSP	Z RHVS 20 R 3/4	
25	S	M 1" BSP	Z RHVS 25 R 1	
30	S	M 1"1/4 BSP	Z RHVS 30 R 1 1/4	
38	S	M 1"1/2 BSP	Z RHVS 38 R 1 1/2	

### Válvula antirretorno tubo-tubo

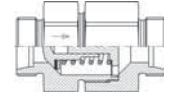

Clapet anti-rétour bidirectionnel tube-tube  
Non-return valve tube-tube  
Valvola di ritegno tubo-tubo

TUBO PIPE	SERIE	REFERENCIA PART N°	€
6	L	Z RHDL 6	
8	L	Z RHDL 8	
10	L	Z RHDL 10	
12	L	Z RHDL 12	
15	L	Z RHDL 15	
18	L	Z RHDL 18	
22	L	Z RHDL 22	
28	L	Z RHDL 28	
35	L	Z RHDL 35	
42	L	Z RHDL 42	
6	S	Z RHDS 6	
8	S	Z RHDS 8	
10	S	Z RHDS 10	
12	S	Z RHDS 12	
14	S	Z RHDS 14	
16	S	Z RHDS 16	
20	S	Z RHDS 20	
25	S	Z RHDS 25	
30	S	Z RHDS 30	
38	S	Z RHDS 38	

### Válvula antirretorno tubo-rosca BSP

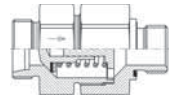

Clapet anti-rétour unidirectionnel à droite tube-mâle  
Non-return valve flow towards male stude end BSP cylindrical  
Valvola di ritegno a destra

TUBO PIPE	SERIE	ROSCA THREAD	REFERENCIA PART N°	€
6	L	M 1/8" BSP	Z RHZL 6 R 1/8	
8	L	M 1/4" BSP	Z RHZL 8 R 1/4	
10	L	M 1/4" BSP	Z RHZL 10 R 1/4	
12	L	M 3/8" BSP	Z RHZL 12 R 3/8	
15	L	M 1/2" BSP	Z RHZL 15 R 1/2	
18	L	M 1/2" BSP	Z RHZL 18 R 1/2	
22	L	M 3/4" BSP	Z RHZL 22 R 3/4	
28	L	M 1" BSP	Z RHZL 28 R 1	
35	L	M 1"1/4 BSP	Z RHZL 35 R 1 1/4	
42	L	M 1"1/2 BSP	Z RHZL 42 R 1 1/2	
6	S	M 1/4" BSP	Z RHZS 6 R 1/4	
8	S	M 1/4" BSP	Z RHZS 8 R 1/4	
10	S	M 3/8" BSP	Z RHZS 10 R 3/8	
12	S	M 3/8" BSP	Z RHZS 12 R 3/8	
14	S	M 1/2" BSP	Z RHZS 14 R 1/2	
16	S	M 1/2" BSP	Z RHZS 16 R 1/2	
20	S	M 3/4" BSP	Z RHZS 20 R 3/4	
25	S	M 1" BSP	Z RHZS 25 R 1	
30	S	M 1"1/4 BSP	Z RHZS 30 R 1 1/4	
38	S	M 1"1/2 BSP	Z RHZS 38 R 1 1/2	

# Abrazaderas

Colliers  
Clamps  
Collari fissatubo

## Abrazadera ligera simple completa



Collier simple complet  
Complete simple clamp  
Collari fissatubo singoli completo

DN	GRUPO GROUP	REFERENCIA PART N°	€
6	G-1	ZA40AZ06	
8	G-1	ZA40AZ08	
10	G-1	ZA40AZ10	
12	G-1	ZA40AZ12	
14	G-2	ZA40AZ14	
15	G-2	ZA40AZ15	
16	G-2	ZA40AZ16	
18	G-2	ZA40AZ18	
20	G-3	ZA40AZ20	
22	G-3	ZA40AZ22	
23	G-3	ZA40AZ23	
25	G-3	ZA40AZ25	
28	G-4	ZA40AZ28	
30	G-4	ZA40AZ30	
38	G-5	ZA40AZ38	
40	G-5	ZA40AZ40	
42	G-5	ZA40AZ42	

## Abrazadera ligera reforzada completa



Collier de fixation simple série légère renforcé complet  
Complete reinforced clamp  
Collare fissatubo rin forzato completo

DN	GRUPO GROUP	REFERENCIA PART N°	€
6	G-1	ZA41AZ06	
8	G-1	ZA41AZ08	
10	G-1	ZA41AZ10	
12	G-1	ZA41AZ12	
14	G-2	ZA41AZ14	
15	G-2	ZA41AZ15	
16	G-2	ZA41AZ16	
18	G-2	ZA41AZ18	
20	G-3	ZA41AZ20	
22	G-3	ZA41AZ22	
23	G-3	ZA41AZ23	
25	G-3	ZA41AZ25	
28	G-4	ZA41AZ28	
30	G-4	ZA41AZ30	
38	G-5	ZA41AZ38	
40	G-5	ZA41AZ40	
42	G-5	ZA41AZ42	



Crimp fittings for hoses

Pipe fittings DIN 2353

Flare fittings JIC  
SAE flanges

Adaptors

Welding fittings

Industrial fittings

Several items

# Abrazaderas

Colliers  
Clamps  
Collari fissatubo

Crimp fittings for hoses

Pipe fittings DIN 2353

Flare fittings JIC  
SAE flanges

Adaptors

Welding fittings

Industrial fittings

Several items

## Plásticos polipropileno, serie ligera



Plastique polypropylène, série légère  
Plastics polypropylene, light serie  
Plastica polipropilene

DN	GRUPO GROUP	REFERENCIA PART N°	€
6	1	A106C	
8	1	A108C	
10	1	A110C	
12	1	A112C	
1/4"	2	A213.2C	
14	2	A214C	
15	2	A215C	
3/8"	2	A216.7C	
16	2	A216C	
18	2	A218C	
19	3	A319C	
20	3	A320C	
1/2"	3	A321.3C	
22	3	A322C	
23	3	A323C	
25	3	A325C	
3/4"	4	A426.7C	
28	4	A428C	
30	4	A430C	
32	5	A532C	
1"	5	A533.3C	
35	5	A535C	
38	5	A538C	
40	5	A540C	
42	5	A542C	
44.5	6	A644.5C	
1"1/2	6	A648.3C	
50.8	6	A650.8C	

Precio por pareja//Prix par paire//Price per couple//Prezzo per coppia

## Chapas superiores, serie ligera



Plaque supérieure, série légère  
Upper plate, light serie  
Piastra superiore

GRUPO GROUP	REFERENCIA PART N°	€
1	ZAPS1	
2	ZAPS2	
3	ZAPS3	
4	ZAPS4	
5	ZAPS5	
6	ZAPS6	

## Tornillos Allen, serie ligera



Vis Allen, série légère  
Allen screw, light serie  
Vite Allen

ROSCA THREAD	GRUPO GROUP	REFERENCIA PART N°	€
M6	1	ZAVTC1	
M6	2	ZAVTC2	
M6	3	ZAVTC3	
M6	4	ZAVTC4	
M6	5	ZAVTC5	
M6	6	ZAVTC6	

Precio por unidad//Prix à l'unité//Price per unit//Prezzo unitario

## Chapas inferiores, serie ligera



Plaque inférieure, série légère  
Lower plate, light serie  
Piastra inferiori

GRUPO GROUP	REFERENCIA PART N°	€
1	ZAPIN1	
2	ZAPIN2	
3	ZAPIN3	
4	ZAPIN4	
5	ZAPIN5	
6	ZAPIN6	

## Tornillos Hexagonales, serie ligera



Vis Hexagonnel, série légère  
Hexagonal screw, light serie  
Vite esagonale

ROSCA THREAD	GRUPO GROUP	REFERENCIA PART N°	€
M6	1	ZAVTE1	
M6	2	ZAVTE2	
M6	3	ZAVTE3	
M6	4	ZAVTE4	
M6	5	ZAVTE5	
M6	6	ZAVTE6	

Precio por unidad//Prix à l'unité//Price per unit//Prezzo unitario



# Abrazaderas

Colliers  
Clamps  
Collari fissatubo

## Abrazaderas dobles completas



Colliers de fixation doubles complets  
Double clamp - parallel  
Collare fissatubo doppio completo

DN	GRUPO GROUP	REFERENCIA PART N°	€
6	G.1	ZAZCFS06	
8	G.1	ZAZCFS08	
10	G.1	ZAZCFS10	
12	G.1	ZAZCFS12	
14	G.2	ZAZCFS14	
15	G.2	ZAZCFS15	
16	G.2	ZAZCFS16	
18	G.2	ZAZCFS18	
20	G.3	ZAZCFS20	
22	G.3	ZAZCFS22	
25	G.3	ZAZCFS25	
28	G.4	ZAZCFS28	
30	G.4	ZAZCFS30	
35	G.5	ZAZCFS35	
38	G.5	ZAZCFS38	
40	G.5	ZAZCFS40	
42	G.5	ZAZCFS42	

## Chapas inferiores



Plaques inférieures à souder double  
Lower plate double  
Piastre inferiori

ROSCA THREAD	GRUPO GROUP	REFERENCIA PART N°	€
M6	1	ZADPIN1	
M8	2	ZADPIN2	
M8	3	ZADPIN3	
M8	4	ZADPIN4	
M8	5	ZADPIN5	

## Chapas superiores



Plaques supérieures de protection double  
Upper plate double  
Piastre superiori

GRUPO GROUP	REFERENCIA PART N°	€
1	ZADPS1	
2	ZADPS2	
3	ZADPS3	
4	ZADPS4	
5	ZADPS5	

## Plásticos polipropileno



Plastique polypropylene double  
Plastics polypropylene double  
Plastica polipropilene

DN	GRUPO GROUP	REFERENCIA PART N°	€
6	1	AD106C	
8	1	AD108C	
10	1	AD110C	
12	1	AD112C	
1/4"	2	AD213.2C	
14	2	AD214C	
15	2	AD215C	
3/8"	2	AD216.7C	
16	2	AD216C	
18	2	AD218C	
19	3	AD319C	
20	3	AD320C	
1/2"	3	AD321.3C	
22	3	AD322C	
25	3	AD325C	
3/4"	4	AD426.7C	
26	4	AD426C	
28	4	AD428C	
30	4	AD430C	
1"	5	AD533.3C	
33	5	AD533C	
35	5	AD535C	
38	5	AD538C	
40	5	AD540C	
42	5	AD542C	

Precio por pareja//Prix par paire//Price per couple//Prezzo per coppia

## Tornillos cabeza hexagonal



Vis hexagonale  
Hexagonal bolt double  
Vite esagonale

ROSCA THREAD	GRUPO GROUP	REFERENCIA PART N°	€
M6	1	ZADVTE1	
M8	2	ZADVTE2	
M8	3	ZADVTE3	
M8	4	ZADVTE4	
M8	5	ZADVTE5	

Precio por unidad//Prix à l'unité//Price per unit//Prezzo unitario

# Abrazaderas

Colliers  
Clamps  
Collari fissatubo

## Accesorios para carril



Accessoires pour rail  
Rail accessories  
Accessori per lane

ROSCA THREAD	Descripción Description	REFERENCIA PART N°	€
M6	Tuerca carril	TC6I	
M8	Tuerca carril	TC8I	
--	Carril guía (simples/dobles)	TS11I	
--	Carril guía (simples/dobles)	TS14I	

## Chapas inferiores, serie pesada



Plaque inférieure, série lourde  
Lower plate, heavy serie  
Piastre inferiori, serie pesante

ROSCA THREAD	GRUPO GROUP	REFERENCIA PART N°	€
M10	1	ZAPINP1	
M10	2	ZAPINP2	
M10	3	ZAPINP3	
M12	4	ZAPINP4	

## Plásticos polipropileno, serie pesada



Plastique polypropylene, série lourde  
Plastics polypropylene, heavy serie  
Plastica polipropilene, serie pesante

DN	GRUPO GROUP	REFERENCIA PART N°	€
6	1	AMPP106C	
8	1	AMPP108C	
10	1	AMPP110C	
12	1	AMPP112C	
1/4"	1	AMPP113.2C	
14	1	AMPP114C	
15	1	AMPP115C	
16	1	AMPP116C	
18	1	AMPP118C	
20	2	AMPP220C	
1/2"	2	AMPP221.3C	
22	2	AMPP222C	
25	2	AMPP225C	
3/4"	2	AMPP226.7C	
28	2	AMPP228C	
30	2	AMPP230C	
30	3	AMPP330C	
32	3	AMPP332C	
1"	3	AMPP333.3C	
35	3	AMPP335C	
38	3	AMPP338C	
40	3	AMPP340C	
1 1/4"	3	AMPP342.4C	
42	3	AMPP342C	
45	3	AMPP345C	
38	4	AMPP438C	
40	4	AMPP440C	
1 1/4"	4	AMPP442.4C	
42	4	AMPP442C	
45	4	AMPP444.5C	
45	4	AMPP445C	
1 1/4"	4	AMPP448.4C	
48	4	AMPP448C	
50	4	AMPP450C	
55	4	AMPP455C	
2"	4	AMPP460.3C	
60	4	AMPP460C	
65	4	AMPP465C	
70	4	AMPP470C	

Precio por pareja//Prix par paire//Price per couple//Prezzi per

## Chapas superiores, serie pesada



Plaque supérieure, série lourde  
Upper plate, heavy serie  
Piastre superiori, serie pesante

GRUPO GROUP	REFERENCIA PART N°	€
1	ZAPSP1	
2	ZAPSP2	
3	ZAPSP3	
4	ZAPSP4	

## Tornillos, serie pesada



Vis, série lourde  
Screw, heavy serie  
Vite, serie pesante

ROSCA THREAD	GRUPO GROUP	REFERENCIA PART N°	€
M10	1	ZAVTEP1	
M10	2	ZAVTEP2	
M10	3	ZAVTEP3	
M12	4	ZAVTEP4	

Precio por unidad//Prix à l'unité//Price per unit//Prezzo unitario

# 3

Racores JIC 37° / Bridas SAE

Raccords JIC 37° / Brides SAE

Flare fittings JIC 37° / SAE Flanges

Raccordi JIC 37° / Flange SAE

▶ Racores JIC 37°	114
Raccords JIC 37°   Flare fittings JIC 37°   Raccordi JIC 37°	
▶ Bridas SAE	115
Brides SAE   SAE Flanges   Flange SAE	

# Racores JIC 37°

Raccords JIC 37° | Flare fittings JIC 37° | Raccordi JIC 37°

## Tuercas, ferulas y tapones JIC 37° | Écrous, ferrules et bouchons JIC 37° | JIC 37° Nuts, sleeves and plugs | Dadi, bussole e tappi JIC 37°

117

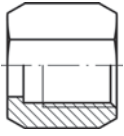

ZS110

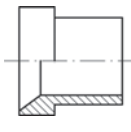

ZS120

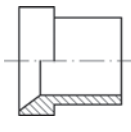

ZS121

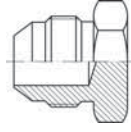

ZS140

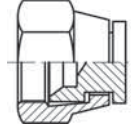

ZS130

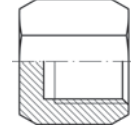

ZS132

## Uniones rectas JIC 37° | Union droite JIC 37° | JIC 37° Straight unions | Adattatori diritti JIC 37°

119

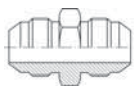

ZS260

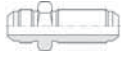

ZS250



ZS240

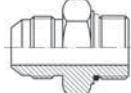

ZS260\_OR

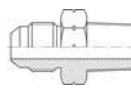

ZS200

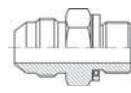

ZS230

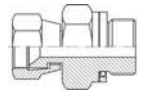

ZS180

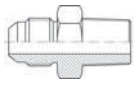

ZS210

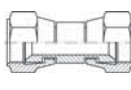

ZS730

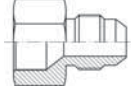

ZS290

## Codos 90 JIC 37° | Coudes 90° JIC 37° | JIC 37° 90° Elbows | Adattatori a 90° JIC 37°

120

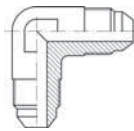

ZS500

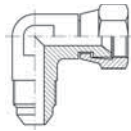

ZS675

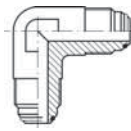

ZS500\_OR

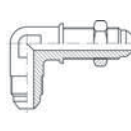

ZS650

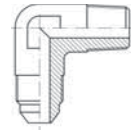

ZS550

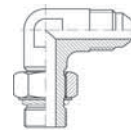

ZS570

## Codos 45 JIC 37° | Coudes 45° JIC 37° | JIC 37° 45° Elbows | Adattatori a 45° JIC 37°

121



ZS690

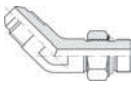

ZS775

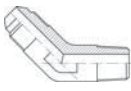

ZS725

## Racores JIC 37° - NPT | Raccords JIC 37° - NPT | JIC 37° - NPT unions | Adattatori JIC 37° - NPT

122

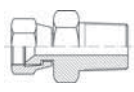

ZS185

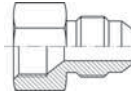

ZS295

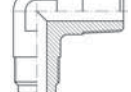

ZS525

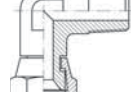

ZS595

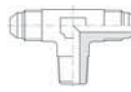

ZS625

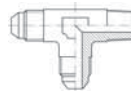

ZS630

## Tes JIC 37° | Tés JIC 37° | JIC 37° Tees | Adattatori a T JIC 37°

123

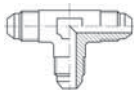

ZS505

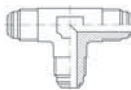

ZS505\_OR

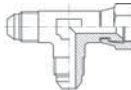

ZS680

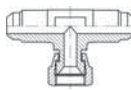

ZS685

► Bidas SAE

Bidas SAE | SAE Flanges | Flange SAE

► **Bidas roscadas** | Brides taraudées | Threaded flanges | Flange filettate 125

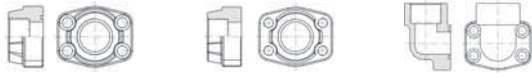

ZBBRG

ZBCRG

ZB90RG

► **Bidas soldables tubo gas** | Brides à souder pour tube gaz | Welding flanges for gas tube | Flange a saldare per tubo gas 126

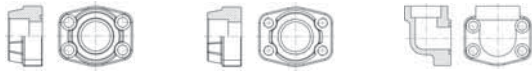

ZBBSG

ZBCSG

ZB90SG

► **Bidas soldables tubo Métrico** | Brides à souder pour tube métrique | Welding flanges for metric tube | Flange a saldare per tubo Metrico 127

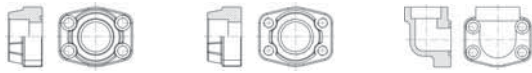

ZBBSM

ZBCSM

ZB90SM

► **Bidas ciegas** | Brides avec obturateur fermé | Blind flanges | Flange cieche 128



ZBBC

ZBCC

► **Bidas para flexibles** | Bidas SAE pour flexibles | SAE Flanges for hoses | Flange SAE per tubi flessibili 129

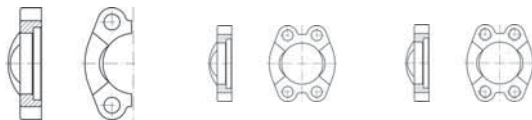

ZBBP

ZBBE

ZBCE

► **Conos soldar** | Collets à souder | Welding adaptors for flanges | Ogive a saldare 130

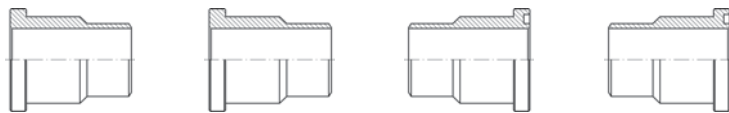

ZBSM\*1

ZBSG\*1

ZBSM\*0

ZBSG\*0

Crimp fittings for hoses

Pipe fittings DIN 2353

Flare fittings JIC  
SAE flanges

Adaptors

Welding fittings

Industrial fittings

Several items



## Racores JIC 37°

Raccords JIC 37°  
Flare fittings JIC 37°  
Raccordi JIC 37°

### Tuercas JIC 37°

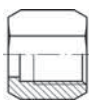

Écrou JIC 37°

Nut JIC 37°

Dado JIC

TUBO PIPE	ROSCA THREAD	REFERENCIA PART N°	€
6	1/4	7/16" 20h UNF	<b>ZS11006</b>
8	5/16	1/2" 20h UNF	<b>ZS11008</b>
10	3/8	9/16" 18h UNF	<b>ZS11010</b>
12	1/2	3/4" 16h UNF	<b>ZS11012</b>
14-15-16	5/8	7/8" 14h UNF	<b>ZS11016</b>
18-20	-	1"1/16 12h UN	<b>ZS11020</b>
-	3/4	1"1/16 12h UNF	<b>ZS11020W</b>
25	1	1"5/16 12h UN	<b>ZS11025</b>
30-32	1 1/4	1"5/8 12h UN	<b>ZS11032</b>
38	1 1/2	1"7/8 12h UN	<b>ZS11038</b>

### Ferulas JIC 37° (tubo métrico)

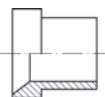

Ferrules JIC 37° pour tube Métrique

Tube sleeves Metric JIC 37°

Bussola JIC 37° per tubo Metrico

TUBO PIPE	REFERENCIA PART N°	€
6	<b>ZS12006</b>	
8	<b>ZS12008</b>	
10	<b>ZS12010</b>	
12	<b>ZS12012</b>	
14	<b>ZS12014</b>	
15	<b>ZS12015</b>	
16	<b>ZS12016</b>	
18	<b>ZS12018</b>	
20	<b>ZS12020</b>	
25	<b>ZS12025</b>	
30	<b>ZS12030</b>	
32	<b>ZS12032</b>	
38	<b>ZS12038</b>	

### Ferulas JIC 37° (tubo Gas)

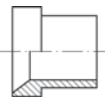

Ferrules JIC 37° pour tube Gaz

Tube sleeves Gas JIC 37°

Bussola JIC 37° per tubo gas

TUBO PIPE	REFERENCIA PART N°	€
1/4" GAS	<b>ZS12104</b>	
5/16" GAS	<b>ZS12105</b>	
3/8" GAS	<b>ZS12106</b>	
1/2" GAS	<b>ZS12108</b>	
5/8" GAS	<b>ZS12110</b>	
3/4" GAS	<b>ZS12112</b>	
1" GAS	<b>ZS12116</b>	
1" 1/4 GAS	<b>ZS12120</b>	
1" 1/2 GAS	<b>ZS12124</b>	
2" GAS	<b>ZS12132</b>	

### Tapón macho JIC 37°

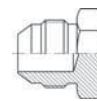

Bouchon mâle JIC 37°

Plug male JIC 37°

Tappo maschio JIC 37°

TUBO PIPE	ROSCA THREAD	REFERENCIA PART N°	€
6	1/4	7/16" 20h UNF	<b>ZS14006</b>
8	5/16	1/2" 20h UNF	<b>ZS14008</b>
10	3/8	9/16" 18h UNF	<b>ZS14010</b>
12	1/2	3/4" 16h UNF	<b>ZS14012</b>
14-15-16	5/8	7/8" 14h UNF	<b>ZS14016</b>
18-20	3/4	1"1/16 12h UN	<b>ZS14020</b>
25	1	1"5/16 12h UN	<b>ZS14025</b>
30-32	1 1/4	1"5/8 12h UN	<b>ZS14032</b>
38	1 1/2	1"7/8 12h UN	<b>ZS14038</b>

### Tapón hembra giratoria JIC 37°



Bouchon femelle JIC 37°

Plug female JIC 37°

Tappo femmina girevole JIC 37°

TUBO PIPE	ROSCA THREAD	REFERENCIA PART N°	€
6	1/4	7/16"-20h UNF	<b>ZS13006</b>
8	5/16	1/2"-20h UNF	<b>ZS13008</b>
10	3/8	9/16"-18h UNF	<b>ZS13010</b>
12	1/2	3/4"-16h UNF	<b>ZS13012</b>
14-15-16	5/8	7/8"-14h UNF	<b>ZS13016</b>
18-20	3/4	1"1/16-12h UN	<b>ZS13020</b>
25	1	1"5/16-12h UN	<b>ZS13025</b>
30-32	1 1/4	1"5/8-12h UN	<b>ZS13032</b>
38	1 1/2	1"7/8-12h UN	<b>ZS13038</b>

### Tapón hembra fija JIC 37°



Bouchon femelle fixe JIC 37°

Plug female fixed JIC 37°

Tappo femmina fissa JIC

TUBO PIPE	ROSCA THREAD	REFERENCIA PART N°	€
10	3/8"	9/16"-18h UNF	<b>ZS13210</b>
12	1/2"	3/4"-16h UNF	<b>ZS13212</b>
14-15-16	5/8"	7/8"-14h UNF	<b>ZS13216</b>
18-20	3/4"	1"1/16-12h UN	<b>ZS13220</b>
25	1"	1"5/16-12h UN	<b>ZS13225</b>
30-32	1"1/4	1"5/8-12h UN	<b>ZS13232</b>

Hasta fin de existencias//Jusqu'à fin du stock//Until end of stock//Fino ad esaurimento scorta

## Racores JIC 37°

Raccords JIC 37°  
Flare fittings JIC 37°  
Raccordi JIC 37°

### Racor macho-macho JIC 37°

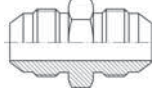

Adapteur droit mâle JIC 37°  
Straight union JIC 37°  
Niples di giunzione JIC

TUBO PIPE		ROSCA THREAD	REFERENCIA PART N°	€
6	1/4	7/16" 20h UNF	ZS26006	
8	5/16	1/2" 20h UNF	ZS26008	
10	3/8	9/16" 18h UNF	ZS26010	
12	1/2	3/4" 16h UNF	ZS26012	
14-15-16	5/8	7/8" 14h UNF	ZS26016	
18-20	3/4	1" 1/16 12h UN	ZS26020	
25	1	1" 5/16 12h UN	ZS26025	
30-32	1 1/4	1" 5/8 12h UN	ZS26032	
38	1 1/2	1" 7/8 12h UN	ZS26038	

### Racor macho-macho JIC 37° con junta

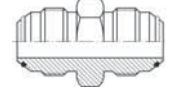

Adapteur droit mâle JIC 37° avec o'ring  
Straight union JIC 37° with o'ring  
Niples di giunzione JIC con o'ring

TUBO PIPE		ROSCA THREAD	REFERENCIA PART N°	€
6	1/4	7/16" 20h UNF	ZS26006OR	
8	5/16	1/2" 20h UNF	ZS26008OR	
10	3/8	9/16" 18h UNF	ZS26010OR	
12	1/2	3/4" 16h UNF	ZS26012OR	
14-15-16	5/8	7/8" 14h UNF	ZS26016OR	
18-20	3/4	1" 1/16 12h UN	ZS26020OR	
25	1	1" 5/16 12h UN	ZS26025OR	
30-32	1 1/4	1" 5/8 12h UN	ZS26032OR	
38	1 1/2	1" 7/8 12h UN	ZS26038OR	

### Racor pasatabiques JIC 37°

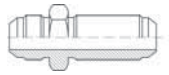

Union passe cloison droite mâle JIC 37° équipé  
Straight bulkhead fitting JIC 37°  
Niples passaparete JIC

TUBO PIPE		ROSCA THREAD	REFERENCIA PART N°	€
6	1/4	7/16" 20h UNF	ZS25006	
8	5/16	1/2" 20h UNF	ZS25008	
10	3/8	9/16" 18h UNF	ZS25010	
12	1/2	3/4" 16h UNF	ZS25012	
14-15-16	5/8	7/8" 14h UNF	ZS25016	
18-20	3/4	1" 1/16 12h UN	ZS25020	
25	1	1" 5/16 12h UN	ZS25025	
30-32	1 1/4	1" 5/8 12h UN	ZS25032	
38	1 1/2	1" 7/8 12h UN	ZS25038	

### Racor macho JIC 37° - macho NPT

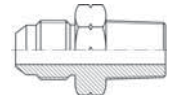

Adapteur mâle JIC 37° - male NPT (BRIGGS)  
Straight adaptor male JIC 37° - male NPT  
Niples di congiunzione JIC 37° - NPT

TUBO PIPE		ROSCA THREAD		REFERENCIA PART N°	€
6	1/4	1/8" NPT	7/16" 20h UNF	ZS2000610	
6	1/4	1/4" NPT	7/16" 20h UNF	ZS2000613	
8	5/16	1/8" NPT	1/2" 20h UNF	ZS2000810	
8	5/16	1/4" NPT	1/2" 20h UNF	ZS2000813	
10	3/8	1/8" NPT	9/16" 18h UNF	ZS2001010	
10	3/8	1/4" NPT	9/16" 18h UNF	ZS2001013	
10	3/8	3/8" NPT	9/16" 18h UNF	ZS2001017	
10	3/8	1/2" NPT	9/16" 18h UNF	ZS2001021	
12	1/2	3/8" NPT	3/4" 16h UNF	ZS2001217	
12	1/2	1/2" NPT	3/4" 16h UNF	ZS2001221	
12	1/2	3/4" NPT	3/4" 16h UNF	ZS2001226	
14-15-16	5/8	1/2" NPT	7/8" 14h UNF	ZS2001621	
14-15-16	5/8	3/4" NPT	7/8" 14h UNF	ZS2001626	
18-20	3/4	1/2" NPT	1" 1/16 12h UN	ZS2002021	
18-20	3/4	3/4" NPT	1" 1/16 12h UN	ZS2002026	
18-20	3/4	1" NPT	1" 1/16 12h UN	ZS2002033	
25	1	3/4" NPT	1" 5/16 12h UN	ZS2002526	
25	1	1" NPT	1" 5/16 12h UN	ZS2002533	
30-32	1	1" 1/4 NPT	1" 5/16 12h UN	ZS2002542	
30-32	1 1/4	1" NPT	1" 5/8 12h UN	ZS2003233	
30-32	1 1/4	1 1/4" NPT	1" 5/8 12h UN	ZS2003242	
38	1 1/2	1 1/4" NPT	1" 7/8 12h UN	ZS2003842	
38	1 1/2	1 1/2" NPT	1" 7/8 12h UN	ZS2003848	

### Racor macho JIC 37° - macho Métrico

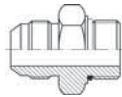

Adapteur mâle JIC 37° - mâle Métrique  
Metric adaptor male - male JIC 37°  
Niples di congiunzione maschio JIC 37° - maschio Metrico

TUBO PIPE		ROSCA THREAD		REFERENCIA PART N°	€
6	1/4	M10x1	7/16" 20h UNF	ZS2400610	
8	5/16	M12x1.5	1/2" 20h UNF	ZS2400812	
10	3/8	M14x1.5	9/16" 18h UNF	ZS2401014	
10	3/8	M16x1.5	9/16" 18h UNF	ZS2401016	
12	1/2	M14x1.5	3/4" 16h UNF	ZS2401214	
12	1/2	M16x1.5	3/4" 16h UNF	ZS2401216	
12	1/2	M18x1.5	3/4" 16h UNF	ZS2401218	
14-15-16	5/8	M18x1.5	7/8" 14h UNF	ZS2401418	
14-15-16	5/8	M22x1.5	7/8" 14h UNF	ZS2401622	
18-20	3/4	M22x1.5	1" 1/16 12h UN	ZS2402022	
18-20	3/4	M27X2	1" 1/16 12h UN	ZS2402027	
25	1	M33x2	1" 5/16 12h UN	ZS2402533	
30-32	1 1/4	M42x2	1" 5/8 12h UN	ZS2403242	
38	1 1/2	M50x2	1" 7/8 12h UN	ZS2403850	



## Racores JIC 37°

Raccords JIC 37°  
Flare fittings JIC 37°  
Raccordi JIC 37°

### Racor macho JIC 37° - macho BSP

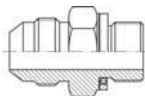

Adapteur mâle JIC 37° - mâle BSP équipé  
Straight adaptor male JIC 37° - male BSP  
Niples di congiunzione JIC - BSP

TUBO PIPE	ROSCA THREAD	REFERENCIA PART N°	€		
6	1/4	7/16" 20h UNF	1/8" BSP	ZS2300610	
6	1/4	7/16" 20h UNF	1/4" BSP	ZS2300613	
6	1/4	7/16" 20h UNF	3/8" BSP	ZS2300617	
6	1/4	7/16" 20h UNF	1/2" BSP	ZS2300621	
8	5/16	1/2" 20h UNF	1/4" BSP	ZS2300813	
8	5/16	1/2" 20h UNF	3/8" BSP	ZS2300817	
10	3/8	9/16" 18h UNF	1/4" BSP	ZS2301013	
10	3/8	9/16" 18h UNF	3/8" BSP	ZS2301017	
10	3/8	9/16" 18h UNF	1/2" BSP	ZS2301021	
12	1/2	3/4" 16h UNF	1/4" BSP	ZS2301213	
12	1/2	3/4" 16h UNF	3/8" BSP	ZS2301217	
12	1/2	3/4" 16h UNF	1/2" BSP	ZS2301221	
12	1/2	3/4" 16h UNF	3/4" BSP	ZS2301226	
14-15-16	5/8	7/8" 14h UNF	3/8" BSP	ZS2301617	
14-15-16	5/8	7/8" 14h UNF	1/2" BSP	ZS2301621	
18-20	3/4	1" 1/16 12h UN	1/2" BSP	ZS2302021	
18-20	3/4	1" 1/16 12h UN	3/4" BSP	ZS2302026	
18-20	3/4	1" 1/16 12h UN	1" BSP	ZS2302033	
25	1	1" 5/16 12h UN	3/4" BSP	ZS2302526	
25	1	1" 5/16 12h UN	1" BSP	ZS2302533	
25	1	1" 5/16 12h UN	1" 1/4 BSP	ZS2302542	
30-32	1	1" 5/8 12h UN	1" BSP	ZS2303233	
30-32	1 1/4	1" 5/8 12h UN	1" 1/4 BSP	ZS2303242	
38	1 1/2	1" 7/8 12h UN	1" 1/4 BSP	ZS2303842	
38	1 1/2	1" 7/8 12h UN	1" 1/2 BSP	ZS2303848	
38	2	1" 7/8 12h UN	2" BSP	ZS2303860	

### Racor macho BSP - hembra giratoria JIC 37°

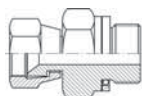

Adapteur mâle BSP - femelle tournante JIC 37°  
Straight adaptor male BSP - swivel female JIC 37°  
Niples di congiunzione maschio BSP - femmina JIC 37°

TUBO PIPE	ROSCA THREAD	REF. PART N°	€		
6	1/4	M 1/8" BSP	H 7/16" 20h UNF	ZS1800610	
8	5/16	M 1/4" BSP	H 1/2" 20h UNF	ZS1800813	
10	3/8	M 1/4" BSP	H 9/16" 18h UNF	ZS1801013	
10	3/8	M 3/8" BSP	H 9/16" 18h UNF	ZS1801017	
10	3/8	M 1/2" BSP	H 9/16" 18h UNF	ZS1801021	
12	1/2	M 3/8" BSP	H 3/4" 16h UNF	ZS1801217	
14-15-16	5/8	M 1/2" BSP	H 7/8" 14h UNF	ZS1801621	
18-20	3/4	M 1/2" BSP	H 1" 1/16 12h UNF	ZS1802026	
25	1	M 1" BSP	H 1" 5/16 12h UNF	ZS1802533	
30-32	1 1/4	M 1" 1/4 BSP	H 1" 5/8 12h UNF	ZS1803242	
38	1 1/2	M 1" 1/2 BSP	H 1" 7/8 12h UNF	ZS1803848	

### Racor macho JIC 37° - macho BSPT

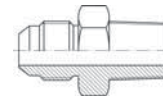

Adapteur mâle JIC 37° - mâle BSPT  
Straight adaptor male JIC 37° - male BSPT  
Niples di congiunzione JIC - BSPT

TUBO PIPE	ROSCA THREAD	REFERENCIA PART N°	€		
6	1/4	7/16" 20h UNF	1/8" BSPT	ZS2100610	
6	1/4	7/16" 20h UNF	1/4" BSPT	ZS2100613	
8	5/16	1/2" 20h UNF	1/8" BSPT	ZS2100810	
8	5/16	1/4" BSPT	1/2" 20h UNF	ZS2100813	
8	5/16	1/2" 20h UNF	3/8" BSPT	ZS2100817	
10	3/8	9/16" 18h UNF	1/4" BSPT	ZS2101013	
10	3/8	9/16" 18h UNF	3/8" BSPT	ZS2101017	
10	3/8	9/16" 18h UNF	1/2" BSPT	ZS2101021	
12	1/2	3/4" 16h UNF	1/4" BSPT	ZS2101213	
12	1/2	3/4" 16h UNF	3/8" BSPT	ZS2101217	
12	1/2	3/4" 16h UNF	1/2" BSPT	ZS2101221	
14-15-16	5/8	7/8" 14h UNF	3/8" BSPT	ZS2101617	
14-15-16	5/8	1/2" BSPT	7/8" 14h UNF	ZS2101621	
14-15-16	5/8	3/4" BSPT	7/8" 14h UNF	ZS2101626	
18-20	3/4	1/2" BSPT	1" 1/16 12h UN	ZS2102021	
18-20	3/4	3/4" BSPT	1" 1/16 12h UN	ZS2102026	
18-20	3/4	1" BSPT	1" 1/16 12h UN	ZS2102033	
25	1	3/4" BSPT	1" 5/16 12h UN	ZS2102526	
25	1	1" BSPT	1" 5/16 12h UN	ZS2102533	
30-32	1 1/4	1" BSPT	1" 5/8 12h UN	ZS2103233	
30-32	1 1/4	1 1/4" BSPT	1" 5/8 12h UN	ZS2103242	
38	1 1/2	1 1/2" BSPT	1" 7/8 12h UN	ZS2103848	

### Racor hembra giratoria - hembra giratoria JIC 37°

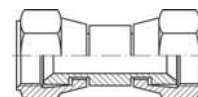

Adapteur femelle tournante JIC 37°  
Straight adaptor swivel female JIC 37°  
Niples femmina - femmina girevole JIC

TUBO PIPE	ROSCA THREAD	REFERENCIA PART N°	€	
6	1/4	7/16" 20h UNF	ZS73006	
8	5/16	1/2" 20h UNF	ZS73008	
10	3/8	9/16" 18h UNF	ZS73010	
12	1/2	3/4" 16h UNF	ZS73012	
14-15-16	5/8	7/8" 14h UNF	ZS73016	
18-20	3/4	1" 1/16 12h UN	ZS73020	
25	1	1" 5/16 12h UN	ZS73025	
32	1 1/4	1" 5/8 12h UN	ZS73032	
38	1 1/2	1" 7/8 12h UN	ZS73038	

## Racores JIC 37°

Raccords JIC 37°  
Flare fittings JIC 37°  
Raccordi JIC 37°

### Racor reducción macho - hembra JIC 37°

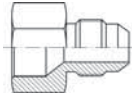

Adaptateur réduction mâle JIC 37° - femelle JIC 37°

Reducer adaptor male JIC 37° - female JIC 37°

Nipples di riduzione maschio - femmina JIC 37°

TUBO PIPE		ROSCA THREAD		REF. PART N°	€
10	6	H 9/16" 18h UNF	M 7/16" 20h UNF	ZS2901006	
10	8	H 9/16" 18h UNF	M 1/2" 20h UNF	ZS2901008	
12	6	H 3/4" 16h UNF	M 7/16" 20h UNF	ZS2901206	
12	8	H 3/4" 16h UNF	M 1/2" 20h UNF	ZS2901208	
12	10	H 3/4" 16h UNF	M 9/16" 18h UNF	ZS2901210	
14-15-16	6	H 7/8" 14h UNF	M 7/16" 20h UNF	ZS2901606	
14-15-16	10	H 7/8" 14h UNF	M 9/16" 18h UNF	ZS2901610	
14-15-16	12	H 7/8" 14h UNF	M 3/4" 16h UNF	ZS2901612	
18-20	6	H 1"1/16 12h UN	M 7/16" 20h UNF	ZS2902006	
18-20	10	H 1"1/16 12h UN	M 9/16" 18h UNF	ZS2902010	
18-20	12	H 1"1/16 12h UN	M 3/4" 16h UNF	ZS2902012	
25	18-20	H 1"5/16 12h UN	M 1"1/16 12h UN	ZS2902520	
30-32	18-20	H 1"5/8 12h UN	M 1"1/16 12h UN	ZS2903020	
30-32	25	H 1"5/8 12h UN	M 1"5/16 12h UN	ZS2903225	
38	30-32	H 1"7/8 12h UN	M 1"5/8 12h UN	ZS2903832	

### Codo 90° macho - macho JIC 37°

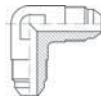

Coude 90° mâle - mâle JIC 37°

90° Elbow male - male JIC 37°

Adattatore a 90° maschio - maschio JIC 37°

TUBO PIPE		ROSCA THREAD		REFERENCIA PART N°	€
6	1/4	7/16" 20h UNF		ZS50006	
8	5/16	1/2" 20h UNF		ZS50008	
10	3/8	9/16" 18h UNF		ZS50010	
12	1/2	3/4" 16h UNF		ZS50012	
14-15-16	5/8	7/8" 14h UNF		ZS50016	
18-20	3/4	1"1/16 12h UN		ZS50020	
25	1	1"5/16 12h UN		ZS50025	
30-32	1 1/4	1"5/8 12h UN		ZS50032	
38	1 1/2	1"7/8 12h UN		ZS50038	

### Codo 90° macho JIC 37° - hembra giratoria JIC 37°



Coude 90° mâle JIC 37° - femelle tournante JIC 37°

90° Elbow swivel female JIC 37° - male JIC 37°

Adattatore a 90° maschio JIC 37° - femmina girevole JIC 37°

TUBO PIPE		ROSCA THREAD		REF. PART N°	€
6	1/4	M 7/16" 20h UNF	H 7/16" 20h UNF	ZS67506	
8	5/16	M 1/2" 20h UNF	H 1/2" 20h UNF	ZS67508	
10	3/8	M 9/16" 18h UNF	H 9/16" 18h UNF	ZS67510	
12	1/2	M 3/4" 16h UNF	H 3/4" 16h UNF	ZS67512	
14-15-16	5/8	M 7/8" 14h UNF	H 7/8" 14h UNF	ZS67516	
18-20	3/4	M 1"1/16 12h UNF	H 1"1/16 12h UNF	ZS67520	
25	1	M 1"5/16 12h UNF	H 1"5/16 12h UNF	ZS67525	
30-32	1 1/4	M 1"5/8 12h UNF	H 1"5/8 12h UNF	ZS67532	
38	1 1/2	M 1"7/8 12h UNF	H 1"7/8 12h UNF	ZS67538	

### Codo 90° macho - macho JIC 37° con junta

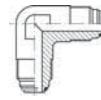

Coude 90° mâle - mâle JIC 37° avec o'ring

90° Elbow male - male JIC 37° with o'ring

Adattatore a 90° maschio - maschio JIC 37° con o'ring

TUBO PIPE		ROSCA THREAD		REFERENCIA PART N°	€
6	1/4	7/16" 20h UNF		ZS50006OR	
8	5/16	1/2" 20h UNF		ZS50008OR	
10	3/8	9/16" 18h UNF		ZS50010OR	
12	1/2	3/4" 16h UNF		ZS50012OR	
14-15-16	5/8	7/8" 14h UNF		ZS50016OR	
18-20	3/4	1"1/16 12h UN		ZS50020OR	
25	1	1"5/16 12h UN		ZS50025OR	
30-32	1 1/4	1"5/8 12h UN		ZS50032OR	
38	1 1/2	1"7/8 12h UN		ZS50038OR	

### Codo 90° pasatabiques macho - macho JIC 37°

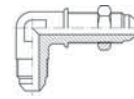

Coude 90° passe cloison mâle-mâle JIC 37°

90° Bulkhead elbow male - male JIC 37°

Adattatore a 90° passaparete maschio - maschio JIC 37°

TUBO PIPE		ROSCA THREAD		REF. PART N°	€
6	1/4	7/16 - 20h UNF	7/16 - 20h UNF	ZS65006	
8	5/16	1/2 - 20h UNF	1/2 - 20h UNF	ZS65008	
10	3/8	9/16 - 18h UNF	9/16 - 18h UNF	ZS65010	
12	1/2	3/4 - 16h UNF	3/4 - 16h UNF	ZS65012	
14-15-16	5/8	7/8 - 14h UNF	7/8 - 14h UNF	ZS65016	
18-20	3/4	1 1/16 - 12h UN	1 1/16 - 12h UN	ZS65020	
25	1	1 5/16 - 12h UN	1 5/16 - 12h UN	ZS65025	

## Racores JIC 37°

Raccords JIC 37°  
Flare fittings JIC 37°  
Raccordi JIC 37°

### Codo 90° macho JIC 37° - macho BSPT



Coude 90° mâle JIC 37° - mâle BSPT  
90° Elbow male JIC 37° - male BSPT

Adattatore a 90° maschio JIC 37° - maschio BSPT

TUBO PIPE	ROSCA THREAD	REFERENCIA PART N°	€
6	1/4	1/8" BSPT 7/16" 20h UNF	ZS5500610
6	1/4	1/4" BSPT 7/16" 20h UNF	ZS5500613
8	5/16	1/8" BSPT 1/2" 20h UNF	ZS5500810
8	5/16	1/4" BSPT 1/2" 20h UNF	ZS5500813
10	3/8	1/4" BSPT 9/16" 18h UNF	ZS5501013
10	3/8	3/8" BSPT 9/16" 18h UNF	ZS5501017
10	3/8	1/2" BSPT 9/16" 18h UNF	ZS5501021
12	1/2	1/4" BSPT 3/4" 16h UNF	ZS5501213
12	1/2	3/8" BSPT 3/4" 16h UNF	ZS5501217
12	1/2	1/2" BSPT 3/4" 16h UNF	ZS5501221
14-15-16	5/8	3/8" BSPT 7/8" 14h UNF	ZS5501617
14-15-16	5/8	1/2" BSPT 7/8" 14h UNF	ZS5501621
14-15-16	5/8	3/4" BSPT 7/8" 14h UNF	ZS5501626
18-20	3/4	1/2" BSPT 1" 1/16 12h UN	ZS5502021
18-20	3/4	3/4" BSPT 1" 1/16 12h UN	ZS5502026
25	1	3/4" BSPT 1" 5/16 12h UN	ZS5502526
25	1	1" BSPT 1" 5/16 12h UN	ZS5502533
30-32	1 1/4	1 1/4" BSPT 1" 5/8 12h UN	ZS5503242

### Codo 90° regulable macho JIC 37°- macho BSP



Coude 90° orientable mâle JIC 37°- mâle BSP  
90° Adjustable stud elbow male JIC 37°-male BSP

Adattatore a 90° orientabile maschio JIC 37°- maschio BSP

TUBO PIPE	ROSCA THREAD	REFERENCIA PART N°	€
6	1/4	7/16" 20h UNF 1/4" BSP	ZS5700613
10	3/8	9/16" 18h UNF 3/8" BSP	ZS5701017
12	1/2	3/4" 16h UNF 1/2" BSP	ZS5701221
14-15-16	5/8	7/8" 14h UNF 1/2" BSP	ZS5701621
18-20	3/4	1" 1/16 12h UN 3/4" BSP	ZS5702026
25	1	1" 5/16 12h UN 1" BSP	ZS5702533
38	1 1/2	1" 7/8 12h UN 1" 1/2 BSP	ZS5703848

### Codo 45° macho JIC 37° - hembra giratoria JIC 37°

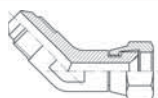

Coude 45° mâle JIC 37° - femelle tournante JIC 37°  
45° Elbow male JIC 37° - swivel female JIC 37°

Adattatore a 45° maschio JIC 37° - femmina girevole JIC 37°

TUBO PIPE	ROSCA THREAD	REF. PART N°	€
6	1/4	M 7/16" 20h UNF H 7/16" 20h UNF	ZS69006
8	5/16	M 1/2" 20h UNF H 1/2" 20h UNF	ZS69008
10	3/8	M 9/16" 18h UNF H 9/16" 18h UNF	ZS69010
12	1/2	M 3/4" 16h UNF H 3/4" 16h UNF	ZS69012
14-15-16	5/8	M 7/8" 14h UNF H 7/8" 14h UNF	ZS69016
18-20	3/4	M 1" 1/16 12h UN H 1" 1/16 12h UN	ZS69020
25	1	M 1" 5/16 12h UN H 1" 5/16 12h UN	ZS69025

### Codo 45° regulable macho - macho JIC 37°

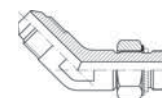

Coude 45° orientable mâle - mâle JIC 37°

45° Adjustable stud elbow male - male JIC 37°

Adattatore a 45° orientabile maschio - maschio JIC 37°

TUBO PIPE	ROSCA THREAD	REF. PART N°	€
6	1/4	7/16 - 20h UNF 7/16 - 20h UNF	ZS77506
8	5/16	1/2 - 20h UNF 1/2 - 20h UNF	ZS77508
10	3/8	9/16 - 18h UNF 9/16 - 18h UNF	ZS77510
12	1/2	3/4 - 16h UNF 3/4 - 16h UNF	ZS77512
14-15-16	5/8	7/8 - 14h UNF 7/8 - 14h UNF	ZS77516
18-20	3/4	1 1/16 - 12h UN 1 1/16 - 12h UN	ZS77520
25	1	1 5/16 - 12h UN 1 5/16 - 12h UN	ZS77525

### Codo 45° macho JIC 37° - macho NPT

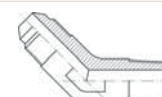

Coude 45° mâle JIC 37° - mâle NPT

45° Elbow male JIC 37° - male NPT

Adattatore a 45° maschio JIC 37° - maschio NPT

TUBO PIPE	ROSCA THREAD	REFERENCIA PART N°	€
6	1/4	1/4" NPT 7/16" 20h UNF	ZS7250613
10	3/8	3/8" NPT 9/16" 18h UNF	ZS7251017
12	1/2	1/2" NPT 3/4" 16h UNF	ZS7251221
18-20	3/4	3/4" NPT 1" 1/16 12h UN	ZS7252026
25	1	1" NPT 1" 5/16 12h UN	ZS7252533

## Racores JIC 37°

Raccords JIC 37°  
Flare fittings JIC 37°  
Raccordi JIC 37°

### Hembra giratoria JIC 37° - macho NPT

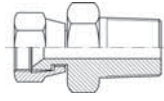

Adaptateur femelle tournante JIC 37° - mâle NPT  
Straight adaptor swivel female JIC 37° - male NPT  
Niples femmina girevole JIC 37° - maschio NPT

DN	ROSCA THREAD	REFERENCIA PART N°	€
1" 5/16 JIC	1" NPT	ZS1852533	

### Codo 90° macho NPT - hembra giratoria JIC 37°

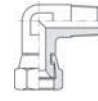

Coude 90° mâle NPT - femelle tournante JIC 37°  
90° Elbow male NPT - swivel female JIC 37°  
Adattatore a 90° maschio NPT - femmina girevole JIC 37°

ROSCA THREAD	REFERENCIA PART N°	€
1/8" NPT	7/16"-20h UNF	ZS5950610
1/4" NPT	1/2"-20h UNF	ZS5950813
1/4" NPT	9/16"-18h UNF	ZS5951013
3/8" NPT	3/4"-16h UNF	ZS5951217
1/2" NPT	7/8"-14h UNF	ZS5951621
3/4" NPT	1"1/16"-12h UN	ZS5952026
1" NPT	1"5/16"-12h UN	ZS5952533

### Racor macho JIC 37° - hembra fija NPT

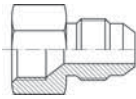

Adaptateur mâle JIC 37° - femelle fixe NPT  
Straight adaptor male JIC 37° - fixed female NPT  
Niples di congiunzione maschio JIC 37° - femmina fissa NPT

TUBO PIPE	ROSCA THREAD	REFERENCIA PART N°	€
10 3/8	M 9/16"-18h UNF H 3/8" NPT	ZS2951017	
12 1/2	M 3/8"-16h UNF H 1/2" NPT	ZS2951221	
18-20 3/4	M 1"1/16-12h UN H 3/4" NPT	ZS2952026	
25 1	M 1"5/16-12 UN H 1" NPT	ZS2952533	

### TES macho JIC 37° - macho NPT - macho JIC 37°

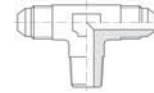

Tés mâle JIC 37° - mâle NPT - mâle JIC 37°  
Tee male JIC 37° - male NPT - male JIC 37°  
Adattatore a T maschio JIC 37° - maschio NPT - maschio JIC 37°

ROSCA THREAD	REFERENCIA PART N°	€	
7/16"-20h UNF	1/8" NPT	7/16"-20h UNF	ZS6250610
1/2"-20h UNF	1/4" NPT	1/2"-20h UNF	ZS6250813
9/16"-18h UNF	1/4" NPT	9/16"-18h UNF	ZS6251013
3/4"-16h UNF	3/8" NPT	3/4"-16h UNF	ZS6251217
7/8"-14h UNF	1/2" NPT	7/8"-14h UNF	ZS6251621
1"1/16-12h UN	3/4" NPT	1"1/16-12h UN	ZS6252026
1"5/16-12h UN	1" NPT	1"5/16-12h UN	ZS6252533

### Codo 90° macho JIC 37° - macho NPT



Coude 90° mâle JIC 37° - mâle NPT  
90° Elbow male JIC 37° - male NPT  
Adattatore a 90° maschio JIC 37° - maschio NPT

TUBO PIPE	ROSCA THREAD	REFERENCIA PART N°	€
6 1/4	1/8" NPT	7/16" 20h UNF	ZS5250610
6 1/4	1/4" NPT	7/16" 20h UNF	ZS5250613
8 5/16	1/8" NPT	1/2" 20h UNF	ZS5250810
8 5/16	1/4" NPT	1/2" 20h UNF	ZS5250813
10 3/8	1/4" NPT	9/16" 18h UNF	ZS5251013
10 3/8	3/8" NPT	9/16" 18h UNF	ZS5251017
10 3/8	1/2" NPT	9/16" 18h UNF	ZS5251021
12 1/2	1/4" NPT	3/4" 16h UNF	ZS5251213
12 1/2	3/8" NPT	3/4" 16h UNF	ZS5251217
12 1/2	1/2" NPT	3/4" 16h UNF	ZS5251221
14-15-16 5/8	3/8" NPT	7/8" 14h UNF	ZS5251617
14-15-16 5/8	1/2" NPT	7/8" 14h UNF	ZS5251621
14-15-16 5/8	3/4" NPT	7/8" 14h UNF	ZS5251626
18-20 3/4	1/2" NPT	1"1/16 12h UN	ZS5252021
18-20 3/4	3/4" NPT	1"1/16 12h UN	ZS5252026
25 1	3/4" NPT	1"5/16 12h UN	ZS5252526
25 1	1" NPT	1"5/16 12h UN	ZS5252533

### TES macho JIC 37° - macho JIC 37° - macho NPT

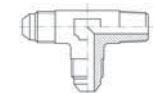

Tés mâle JIC 37° - mâle JIC 37° - mâle NPT  
Tee male JIC 37° - male JIC 37° - male NPT  
Adattatore a T maschio JIC 37° - maschio JIC 37° - maschio NPT

ROSCA THREAD	REFERENCIA PART N°	€	
7/16"-20h UNF	7/16"-20h UNF	1/8" NPT	ZS6300610
1/2"-20h UNF	1/2"-20h UNF	1/4" NPT	ZS6300813
9/16"-18h UNF	9/16"-18h UNF	1/4" NPT	ZS6301013
3/4"-16h UNF	3/4"-16h UNF	3/8" NPT	ZS6301217
7/8"-14h UNF	7/8"-14h UNF	1/2" NPT	ZS6301621
1"1/16-12h UN	1"1/16-12h UN	3/4" NPT	ZS6302026
1"5/16-12h UN	1"5/16-12h UN	1" NPT	ZS6302533

## Racores JIC 37°

Raccords JIC 37°  
Flare fittings JIC 37°  
Raccordi JIC 37°

### TES macho - macho - macho JIC 37°

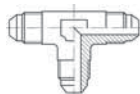

Tés égaux mâle JIC 37°

Union tee male JIC 37°

Adattatore a T maschio JIC 37°

TUBO PIPE		ROSCA THREAD	REFERENCIA PART N°	€
6	1/4	7/16" 20h UNF	ZS50506	
8	5/16	1/2" 20h UNF	ZS50508	
10	3/8	9/16" 18h UNF	ZS50510	
12	1/2	3/4" 16h UNF	ZS50512	
14-15-16	5/8	7/8" 14h UNF	ZS50516	
18-20	3/4	1"1/16 12h UN	ZS50520	
25	1	1"5/16 12h UN	ZS50525	
30-32	1 1/4	1"5/8 12h UN	ZS50532	
38	1 1/2	1"7/8 12h UN	ZS50538	

### TES macho - macho - macho JIC 37° con junta

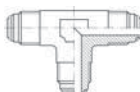

Tés égaux mâle JIC 37° avec o'ring

Union tee male JIC 37° with o'ring

Adattatore a T maschio JIC 37° con o'ring

TUBO PIPE		ROSCA THREAD	REFERENCIA PART N°	€
6	1/4	7/16" 20h UNF	ZS50506OR	
8	5/16	1/2" 20h UNF	ZS50508OR	
10	3/8	9/16" 18h UNF	ZS50510OR	
12	1/2	3/4" 16h UNF	ZS50512OR	
14-15-16	5/8	7/8" 14h UNF	ZS50516OR	
18-20	3/4	1"1/16 12h UN	ZS50520OR	
25	1	1"5/16 12h UN	ZS50525OR	
30-32	1 1/4	1"5/8 12h UN	ZS50532OR	
38	1 1/2	1"7/8 12h UN	ZS50538OR	

### TES macho - macho - hembra giratoria JIC 37°

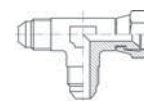

Tés mâle JIC 37° - mâle JIC 37° - femelle tournante JIC 37° au latéral

Swivel run tee male JIC 37° - male JIC 37° - swivel nut JIC 37°

Adattatore a T maschio - maschio - femmina girevole JIC 37°

TUBO PIPE		ROSCA THREAD	REFERENCIA PART N°	€
6	1/4	7/16" 20h UNF	ZS68006	
8	5/16	1/2" 20h UNF	ZS68008	
10	3/8	9/16" 18h UNF	ZS68010	
12	1/2	3/4" 16h UNF	ZS68012	
14-15-16	5/8	7/8" 14h UNF	ZS68016	
18-20	3/4	1"1/16 12h UN	ZS68020	
25	1	1"5/16 12h UN	ZS68025	
32	1 1/4	1"5/8 12h UN	ZS68032	
38	1 1/2	1"7/8 12h UN	ZS68038	

### TES macho - hembra giratoria - macho JIC 37°

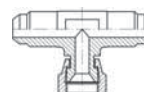

Tés mâle JIC 37° - femelle tournante JIC 37° au centre - mâle JIC 37°

Swivel brunch tee male JIC 37° - swivel nut JIC 37° - male JIC 37°

Adattatore a T maschio - femmina girevole - maschio JIC 37°

TUBO PIPE		ROSCA THREAD	REFERENCIA PART N°	€
6	1/4	7/16" 20h UNF	ZS68506	
8	5/16	1/2" 20h UNF	ZS68508	
10	3/8	9/16" 18h UNF	ZS68510	
12	1/2	3/4" 16h UNF	ZS68512	
14-15-16	5/8	7/8" 14h UNF	ZS68516	
18-20	3/4	1"1/16 12h UN	ZS68520	
25	1	1"5/16 12h UN	ZS68525	
32	1 1/4	1"5/8 12h UN	ZS68532	

# Bridas SAE

Brides SAE | SAE flanges | Flangia SAE

► **Características comunes** | Données communes | Common characteristics | Caratteristiche comuni

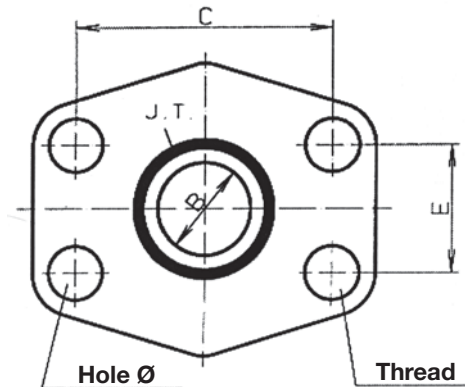

## Bridas 3000 PSI | Brides 3000 PSI | Flanges 3000 PSI | Flangia 3000 PSI

Tamaño   Taille   Size   Misura	Max. pre.   Max. pre.   Max. pre.   Max. pre.	B	C	E	O'ring   O'ring   O'ring   O'ring	Ø	Rosca   Filetage   Thread   Filetto
1/2"	345 bar	13	38,1	17,48	18,64x3,53	9	M8
3/4"	345 bar	19	47,63	22,23	24,99x3,53	11	M10
1	345 bar	25	52,37	26,19	32,92x3,53	11	M10
1" 1/4	276 bar	32	58,72	30,18	37,70x3,53	11,5	M10
1" 1/2	207 bar	38	69,85	35,71	47,22x3,53	13,5	M12
2	207 bar	51	77,77	42,88	56,74x3,53	13,5	M12
2 1/2"	172 bar	63	88,9	50,8	66,27x3,53	13,5	M12
3	138 bar	73	106,38	61,93	85,32x3,53	17,5	M16
3" 1/2	34 bar	89	120,65	69,85	98,02x3,53	17,5	M16
4	34 bar	99	130,18	77,77	110,72x3,53	17,5	M16

## Bridas 6000 PSI | Brides 6000 PSI | Flanges 6000 PSI | Flangia 6000 PSI

Tamaño   Taille   Size   Misura	Max. pre.   Max. pre.   Max. pre.   Max. pre.	B	C	E	O'ring   O'ring   O'ring   O'ring	Ø	Rosca   Filetage   Thread   Filetto
1/2"	414 bar	13	40,49	18,24	18,64x3,53	9	M8
3/4"	414 bar	19	50,8	23,8	24,99x3,53	11	M10
1	414 bar	25	57,15	27,76	32,92x3,53	13	M12
1" 1/4	414 bar	32	66,68	31,75	37,70x3,53	15	M14
1" 1/2	414 bar	38	79,38	36,5	47,22x3,53	17	M16
2	414 bar	51	98,82	44,45	56,74x3,53	21	M20
2 1/2"	414 bar	63	123,8	58,7	66,27x3,53	-	-

## Brida roscada Hembra BSP

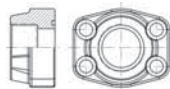

Bride taraudée femelle BSP  
BSP Female threaded flange  
Flangia filettata femmina BSP

SERIE	ROSCA THREAD	TAMAÑO SIZE	REFERENCIA PART N°	€
3000 PSI	1/2" BSP	1/2"	ZBBRG30808	
3000 PSI	3/4" BSP	3/4"	ZBBRG31212	
3000 PSI	1" BSP	1"	ZBBRG31616	
3000 PSI	1"1/4 BSP	1"1/4	ZBBRG32020	
3000 PSI	1"1/2 BSP	1"1/2	ZBBRG32424	
3000 PSI	2" BSP	2"	ZBBRG33232	
3000 PSI	2"1/2 BSP	2"1/2	ZBBRG34040	
3000 PSI	3" BSP	3"	ZBBRG34848	
3000 PSI	3"1/2 BSP	3"1/2	ZBBRG35656	
3000 PSI	4" BSP	4"	ZBBRG36464	
6000 PSI	1/2" BSP	1/2"	ZBBRG60808	
6000 PSI	3/4" BSP	3/4"	ZBBRG61212	
6000 PSI	1" BSP	1"	ZBBRG61616	
6000 PSI	1"1/4 BSP	1"1/4	ZBBRG62020	
6000 PSI	1"1/2 BSP	1"1/2	ZBBRG62424	
6000 PSI	2" BSP	2"	ZBBRG63232	

## Contrabrida roscada Hembra BSP

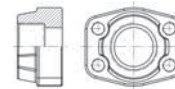

Contre-bride taraudée femelle BSP  
BSP Female threaded counter-flange  
Controflangia filettata femmina BSP

SERIE	ROSCA THREAD	TAMAÑO SIZE	REFERENCIA PART N°	€
3000 PSI	1/2" BSP	1/2"	ZBCRG30808	
3000 PSI	3/4" BSP	3/4"	ZBCRG31212	
3000 PSI	1" BSP	1"	ZBCRG31616	
3000 PSI	1"1/4 BSP	1"1/4	ZBCRG32020	
3000 PSI	1"1/2 BSP	1"1/2	ZBCRG32424	
3000 PSI	2" BSP	2"	ZBCRG33232	
3000 PSI	2"1/2 BSP	2"1/2	ZBCRG34040	
3000 PSI	3" BSP	3"	ZBCRG34848	
3000 PSI	3"1/2 BSP	3"1/2	ZBCRG35656	
3000 PSI	4" BSP	4"	ZBCRG36464	
6000 PSI	1/2" BSP	1/2"	ZBCRG60808	
6000 PSI	3/4" BSP	3/4"	ZBCRG61212	
6000 PSI	1" BSP	1"	ZBCRG61616	
6000 PSI	1"1/4 BSP	1"1/4	ZBCRG62020	
6000 PSI	1"1/2 BSP	1"1/2	ZBCRG62424	
6000 PSI	2" BSP	2"	ZBCRG63232	

## Brida codo 90° roscada Hembra BSP



Bride 90° taraudée femelle BSP  
90° BSP female threaded flange  
Flangia a 90° filettata femmina BSP

SERIE	ROSCA THREAD	TAMAÑO SIZE	REFERENCIA PART N°	€
3000 PSI	1/2" BSP	1/2"	ZB90RG30808	
3000 PSI	3/4" BSP	3/4"	ZB90RG31212	
3000 PSI	1" BSP	1"	ZB90RG31616	
3000 PSI	1"1/4 BSP	1"1/4	ZB90RG32020	
3000 PSI	1"1/2 BSP	1"1/2	ZB90RG32424	
3000 PSI	2" BSP	2"	ZB90RG33232	
6000 PSI	1/2" BSP	1/2"	ZB90RG60808	
6000 PSI	3/4" BSP	3/4"	ZB90RG61212	
6000 PSI	1" BSP	1"	ZB90RG61616	
6000 PSI	1"1/4 BSP	1"1/4	ZB90RG62020	
6000 PSI	1"1/2 BSP	1"1/2	ZB90RG62424	

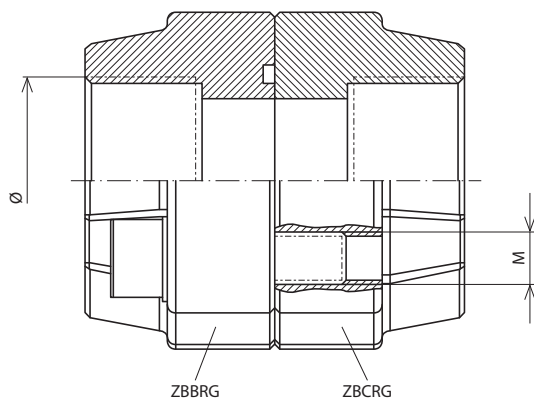

**Junta y Tornillos: a consultar**  
O'ring et Vis: sur demande  
O'ring and Screws: on request  
O'ring e Vite: su richiesta

## Bridas SAE

Brides SAE  
SAE Flanges  
Flange SAE

## Brida soldable Hembra tubo gas

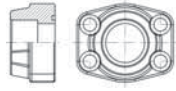

Bride à souder femelle tube gaz  
Welding female flange for gas tube  
Flangia femmina a saldare per tubo gas

SERIE	Ø in	TAMAÑO SIZE	REFERENCIA PART N°	€
3000 PSI	21.6	1/2"	ZBBSG308216	
3000 PSI	27.2	3/4"	ZBBSG312272	
3000 PSI	34.0	1"	ZBBSG316340	
3000 PSI	42.8	1"1/4	ZBBSG320428	
3000 PSI	48.6	1"1/2	ZBBSG324486	
3000 PSI	61.0	2"	ZBBSG332610	
3000 PSI	76.6	2"1/2	ZBBSG340766	
3000 PSI	90.5	3"	ZBBSG348905	
3000 PSI	103.0	3"1/2	ZBBSG3561030	
3000 PSI	115.5	4"	ZBBSG3641155	
6000 PSI	21.6	1/2"	ZBBSG608216	
6000 PSI	27.2	3/4"	ZBBSG612272	
6000 PSI	34.0	1"	ZBBSG616340	
6000 PSI	42.8	1"1/4	ZBBSG620428	
6000 PSI	48.6	1"1/2	ZBBSG624486	
6000 PSI	61.0	2"	ZBBSG632610	

## Contrabrida soldable Hembra tubo gas

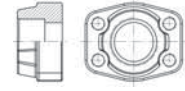

Contre-bride à souder femelle tube gaz  
Welding female counter-flange for gas tube  
Controflangia femmina a saldare per tubo gas

SERIE	Ø in	TAMAÑO SIZE	REFERENCIA PART N°	€
3000 PSI	21.6	1/2"	ZBCSG308216	
3000 PSI	27.2	3/4"	ZBCSG312272	
3000 PSI	34.0	1"	ZBCSG316340	
3000 PSI	42.8	1"1/4	ZBCSG320428	
3000 PSI	48.6	1"1/2	ZBCSG324486	
3000 PSI	61.0	2"	ZBCSG332610	
3000 PSI	76.6	2"1/2	ZBCSG340766	
3000 PSI	90.5	3"	ZBCSG348905	
3000 PSI	103.0	3"1/2	ZBCSG3561030	
3000 PSI	115.5	4"	ZBCSG3641155	
6000 PSI	21.6	1/2"	ZBCSG608216	
6000 PSI	27.2	3/4"	ZBCSG612272	
6000 PSI	34.0	1"	ZBCSG616340	
6000 PSI	42.8	1"1/4	ZBCSG620428	
6000 PSI	48.6	1"1/2	ZBCSG624486	
6000 PSI	61.0	2"	ZBCSG632610	

## Brida codo 90° soldable Hembra tubo gas

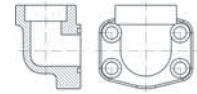

Bride 90° à souder femelle tube gaz  
90° welding female flange for gas tube  
Flangia a 90° femmina a saldare per tubo gas

SERIE	Ø in	TAMAÑO SIZE	REFERENCIA PART N°	€
3000 PSI	21.6	1/2"	ZB90SG308216	
3000 PSI	27.2	3/4"	ZB90SG312272	
3000 PSI	34.0	1"	ZB90SG316340	
3000 PSI	42.8	1"1/4	ZB90SG320428	
3000 PSI	48.6	1"1/2	ZB90SG324486	
3000 PSI	61.0	2"	ZB90SG332610	
6000 PSI	21.6	1/2"	ZB90SG608216	
6000 PSI	27.2	3/4"	ZB90SG612272	
6000 PSI	34.0	1"	ZB90SG616340	
6000 PSI	42.8	1"1/4	ZB90SG620428	
6000 PSI	48.6	1"1/2	ZB90SG624486	

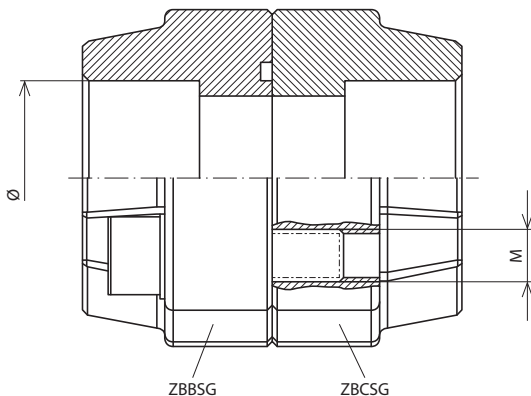

**Junta y Tornillos: a consultar**  
O'ring et Vis: sur demande  
O'ring and Screws: on request  
O'ring e Vite: su richiesta



## Bridas SAE

Bridas SAE  
SAE Flanges  
Flange SAE

### Brida soldable hembra tubo métrico

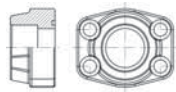

Bride à souder femelle tube métrique  
Female welding flange for metric tube  
Flangia femmina a saldare per tubo Metrico

SERIE	Ø in	TAMAÑO SIZE	REFERENCIA PART N°	€
3000 PSI	20.3	1/2"	ZBBSM308203	
3000 PSI	25.3	3/4"	ZBBSM312253	
3000 PSI	30.3	1"	ZBBSM316303	
3000 PSI	38.3	1"1/4	ZBBSM320383	
3000 PSI	50.5	1"1/2	ZBBSM324505	
6000 PSI	20.3	1/2"	ZBBSM608203	
6000 PSI	25.3	3/4"	ZBBSM612253	
6000 PSI	30.3	1"	ZBBSM616303	
6000 PSI	38.3	1"1/4	ZBBSM620383	
6000 PSI	50.5	1"1/2	ZBBSM624505	

### Brida codo 90° soldable Hembra tubo métrico

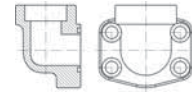

Bride 90° à souder femelle tube métrique  
90° female welding flange for metric tube  
Flangia a 90° femmina a saldare per tubo Metrico

SERIE	Ø in	TAMAÑO SIZE	REFERENCIA PART N°	€
3000 PSI	20.3	1/2"	ZB90SM308203	
3000 PSI	25.3	3/4"	ZB90SM312253	
3000 PSI	30.3	1"	ZB90SM316303	
3000 PSI	38.3	1"1/4	ZB90SM320383	
3000 PSI	50.5	1"1/2	ZB90SM324505	
6000 PSI	20.3	1/2"	ZB90SM608203	
6000 PSI	25.3	3/4"	ZB90SM612253	
6000 PSI	30.3	1"	ZB90SM616303	
6000 PSI	38.3	1"1/4	ZB90SM620383	
6000 PSI	50.5	1"1/2	ZB90SM624505	

### Contrabrida soldable hembra tubo métrico

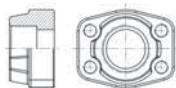

Contre-bride à souder femelle tube métrique  
Female welding counter-flange for metric tube  
Controflangia femmina a saldare per tubo Metrico

SERIE	Ø in	TAMAÑO SIZE	REFERENCIA PART N°	€
3000 PSI	20.3	1/2"	ZBCSM308203	
3000 PSI	25.3	3/4"	ZBCSM312253	
3000 PSI	30.3	1"	ZBCSM316303	
3000 PSI	38.3	1"1/4	ZBCSM320383	
3000 PSI	50.5	1"1/2	ZBCSM324505	
6000 PSI	20.3	1/2"	ZBCSM608203	
6000 PSI	25.3	3/4"	ZBCSM612253	
6000 PSI	30.3	1"	ZBCSM616303	
6000 PSI	38.3	1"1/4	ZBCSM620383	
6000 PSI	50.5	1"1/2	ZBCSM624505	

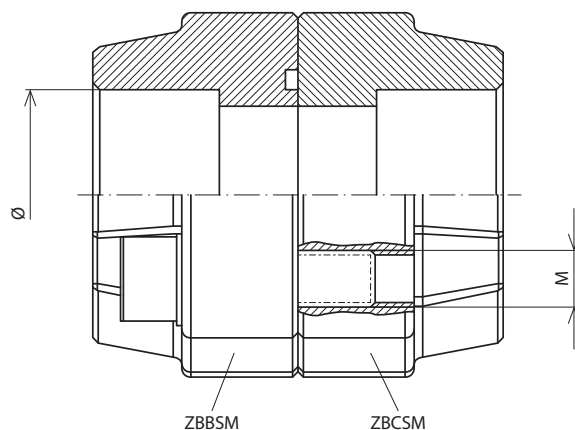

**Junta y Tornillos: a consultar**  
O'ring et Vis: sur demande  
O'ring and Screws: on request  
O'ring e Vite: su richiesta

## Bridas SAE

Bridas SAE  
SAE Flanges  
Flange SAE

### Bridas ciegas

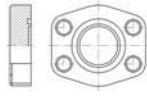

Brides avec obturateur fermé

Blind flanges

Flange cieche

SERIE	TAMAÑO SIZE	REFERENCIA PART N°	€
3000 PSI	1/2"	<b>ZBCC308</b>	
3000 PSI	3/4"	<b>ZBCC312</b>	
3000 PSI	1"	<b>ZBCC316</b>	
3000 PSI	1"1/4	<b>ZBCC320</b>	
3000 PSI	1"1/2	<b>ZBCC324</b>	
3000 PSI	2"	<b>ZBCC332</b>	
3000 PSI	2"1/2	<b>ZBCC340</b>	
3000 PSI	3"	<b>ZBCC348</b>	
3000 PSI	3"1/2	<b>ZBCC356</b>	
3000 PSI	4"	<b>ZBCC364</b>	
6000 PSI	1/2"	<b>ZBCC608</b>	
6000 PSI	3/4"	<b>ZBCC612</b>	
6000 PSI	1"	<b>ZBCC616</b>	
6000 PSI	1"1/4	<b>ZBCC620</b>	
6000 PSI	1"1/2	<b>ZBCC624</b>	
6000 PSI	2"	<b>ZBCC632</b>	

### Contrabridas ciegas

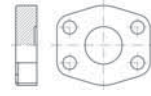

Contre-brides avec obturateur fermé

Blind counter-flanges

Controflange cieche

SERIE	TAMAÑO SIZE	REFERENCIA PART N°	€
3000 PSI	1/2"	<b>ZBCC308</b>	
3000 PSI	3/4"	<b>ZBCC312</b>	
3000 PSI	1"	<b>ZBCC316</b>	
3000 PSI	1"1/4	<b>ZBCC320</b>	
3000 PSI	1"1/2	<b>ZBCC324</b>	
3000 PSI	2"	<b>ZBCC332</b>	
3000 PSI	3"	<b>ZBCC348</b>	
3000 PSI	3"1/2	<b>ZBCC356</b>	
3000 PSI	4"	<b>ZBCC364</b>	
6000 PSI	1/2"	<b>ZBCC608</b>	
6000 PSI	3/4"	<b>ZBCC612</b>	
6000 PSI	1"	<b>ZBCC616</b>	
6000 PSI	1"1/4	<b>ZBCC620</b>	
6000 PSI	1"1/2	<b>ZBCC624</b>	
6000 PSI	2"	<b>ZBCC632</b>	

# Bridas SAE

Brides SAE  
SAE Flanges  
Flange SAE

## Brida partida pasante

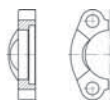

Demi-bride passage total  
SAE Split flange  
Semiflangua SAE

SERIE	Ø in	TAMAÑO SIZE	REFERENCIA PART N°	€
3000 PSI	30.2	1/2"	ZBBP308302	
3000 PSI	38.1	3/4"	ZBBP312381	
3000 PSI	44.5	1"	ZBBP316445	
3000 PSI	50.8	1"1/4	ZBBP320508	
3000 PSI	60.3	1"1/2	ZBBP324603	
3000 PSI	71.4	2"	ZBBP332714	
3000 PSI	102.4	3"	ZBBP3481024	
6000 PSI	31.8	1/2"	ZBBP608318	
6000 PSI	41.3	3/4"	ZBBP612413	
6000 PSI	47.6	1"	ZBBP616476	
6000 PSI	54	1"1/4	ZBBP620540	
6000 PSI	63.5	1"1/2	ZBBP624635	
6000 PSI	79.4	2"	ZBBP632794	

Ver precios en p.35 (CONEXIONES) / Prix à la p.35 (EMBOUTS) / See prices in p.35 (FITTINGS) / Vedere prezzi p.35 (RACCORDI A PRESSARE)

## Brida entera pasante

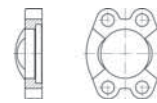

Bride monobloc passage total  
SAE Flange  
Flangua monoblocco SAE

SERIE	Ø in	TAMAÑO SIZE	REFERENCIA PART N°	€
3000 PSI	30.2	1/2"	ZBBE308302	
3000 PSI	38.1	3/4"	ZBBE312381	
3000 PSI	44.5	1"	ZBBE316445	
3000 PSI	50.8	1"1/4	ZBBE320508	
3000 PSI	60.3	1"1/2	ZBBE324603	
3000 PSI	71.4	2"	ZBBE332714	
6000 PSI	31.8	1/2"	ZBBE608318	
6000 PSI	41.3	3/4"	ZBBE612413	
6000 PSI	47.6	1"	ZBBE616476	
6000 PSI	54	1"1/4	ZBBE620540	
6000 PSI	63.5	1"1/2	ZBBE624635	
6000 PSI	79.4	2"	ZBBE632794	

Ver precios en p.35 (CONEXIONES) / Prix à la p.35 (EMBOUTS) / See prices in p.35 (FITTINGS) / Vedere prezzi p.35 (RACCORDI A PRESSARE)

## Contrabrida roscada

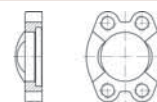

Contre-bride passage total  
SAE counter-flange  
Controflangua SAE

SERIE	Ø in	TAMAÑO SIZE	REFERENCIA PART N°	€
3000 PSI	30.2	1/2"	ZBCE308302	
3000 PSI	38.1	3/4"	ZBCE312381	
3000 PSI	44.5	1"	ZBCE316445	
3000 PSI	50.8	1"1/4	ZBCE320508	
3000 PSI	60.3	1"1/2	ZBCE324603	
3000 PSI	71.4	2"	ZBCE332714	
6000 PSI	31.8	1/2"	ZBCE608318	
6000 PSI	41.3	3/4"	ZBCE612413	
6000 PSI	47.6	1"	ZBCE616476	
6000 PSI	54	1"1/4	ZBCE620540	
6000 PSI	63.5	1"1/2	ZBCE624635	
6000 PSI	79.4	2"	ZBCE632794	

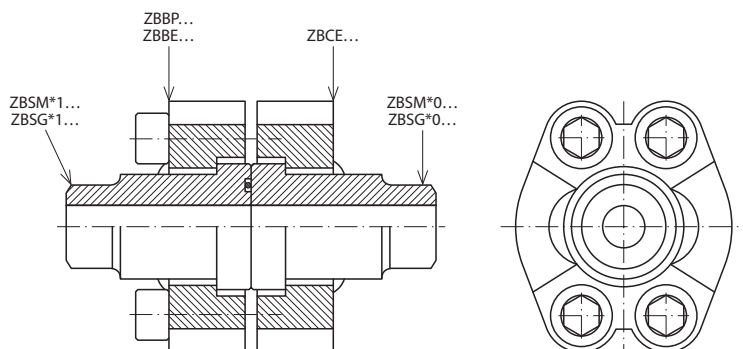

**Junta y Tornillos: a consultar**  
O'ring et Vis: sur demande  
O'ring and Screws: on request  
O'ring e Vite: su richiesta

## Bridas SAE

Brides SAE  
SAE Flanges  
Flange SAE

## Cono soldable tubo métrico con junta

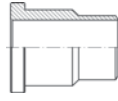

Collet à souder tube métrique avec o'ring  
Welding adaptor for metric tube with o'ring  
Adattatore a saldare per tubo Metrico con o'ring

SERIE	Ø in	TAMAÑO SIZE	REFERENCIA PART N°	€
3000 PSI	16	1/2"	ZBSM3108016	
3000 PSI	25	3/4"	ZBSM3112025	
3000 PSI	30	1"	ZBSM3116030	
3000 PSI	38	1"1/4	ZBSM3120038	
3000 PSI	45	1"1/2	ZBSM3124045	
3000 PSI	60	2"	ZBSM3132060	
3000 PSI	70	2"1/2	ZBSM3140070	
3000 PSI	80	3"	ZBSM3148080	
3000 PSI	100	3"1/2	ZBSM3156100	
3000 PSI	114.3	4"	ZBSM3164114	
3000 PSI	139.7	5"	ZBSM3180139	
6000 PSI	16	1/2"	ZBSM6108016	
6000 PSI	25	3/4"	ZBSM6112025	
6000 PSI	30	1"	ZBSM6116030	
6000 PSI	38	1"1/4	ZBSM6120038	
6000 PSI	45	1"1/2	ZBSM6124045	
6000 PSI	60	2"	ZBSM6132060	

## Cono soldable tubo métrico sin junta

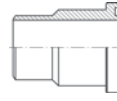

Collet à souder tube métrique sans o'ring  
Welding adaptor for metric tube without o'ring  
Adattatore a saldare per tubo Metrico sin o'ring

SERIE	Ø in	TAMAÑO SIZE	REFERENCIA PART N°	€
3000 PSI	16	1/2"	ZBSM3008016	
3000 PSI	25	3/4"	ZBSM3012025	
3000 PSI	30	1"	ZBSM3016030	
3000 PSI	38	1"1/4	ZBSM3020038	
3000 PSI	45	1"1/2	ZBSM3024045	
3000 PSI	60	2"	ZBSM3032060	
3000 PSI	70	2"1/2	ZBSM3040070	
3000 PSI	80	3"	ZBSM3048080	
3000 PSI	100	3"1/2	ZBSM3056100	
3000 PSI	114.3	4"	ZBSM3064114	
3000 PSI	139.7	5"	ZBSM3080139	
6000 PSI	16	1/2"	ZBSM6008016	
6000 PSI	25	3/4"	ZBSM6012025	
6000 PSI	30	1"	ZBSM6016030	
6000 PSI	38	1"1/4	ZBSM6020038	
6000 PSI	45	1"1/2	ZBSM6024045	
6000 PSI	60	2"	ZBSM6032060	

## Cono soldable tubo gas con junta

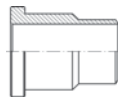

Collet à souder tube gaz avec o'ring  
Welding adaptor for gas tube with o'ring  
Adattatore a saldare per tubo gas con o'ring

SERIE	Ø in	TAMAÑO SIZE	REFERENCIA PART N°	€
3000 PSI	21.5	1/2"	ZBSG3108215	
3000 PSI	28.0	3/4"	ZBSG3112280	
3000 PSI	34.0	1"	ZBSG3116340	
3000 PSI	42.8	1"1/4	ZBSG3120428	
3000 PSI	48.6	1"1/2	ZBSG3124486	
3000 PSI	61.0	2"	ZBSG3132610	
6000 PSI	21.5	1/2"	ZBSG6108215	
6000 PSI	28.0	3/4"	ZBSG6112280	
6000 PSI	34.0	1"	ZBSG6116340	
6000 PSI	42.8	1"1/4	ZBSG6120428	
6000 PSI	48.6	1"1/2	ZBSG6124486	
6000 PSI	61.0	2"	ZBSG6132610	

## Cono soldable tubo gas sin junta

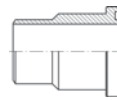

Collet à souder tube gaz sans o'ring  
Welding adaptor for gas tube without o'ring  
Adattatore a saldare per tubo gas sin o'ring

SERIE	Ø in	TAMAÑO SIZE	REFERENCIA PART N°	€
3000 PSI	21.5	1/2"	ZBSG3008215	
3000 PSI	28.0	3/4"	ZBSG3012280	
3000 PSI	34.0	1"	ZBSG3016340	
3000 PSI	42.8	1"1/4	ZBSG3020428	
3000 PSI	48.6	1"1/2	ZBSG3024486	
3000 PSI	61.0	2"	ZBSG3032610	
6000 PSI	21.5	1/2"	ZBSG6008215	
6000 PSI	28.0	3/4"	ZBSG6012280	
6000 PSI	34.0	1"	ZBSG6016340	
6000 PSI	42.8	1"1/4	ZBSG6020428	
6000 PSI	48.6	1"1/2	ZBSG6024486	
6000 PSI	61.0	2"	ZBSG6032610	

# 4

Adaptadores

Adapteurs

Adaptors

Adattatori

▶ Adaptadores BSP	132
Adapteurs BSP   Adaptors BSP   Adattatori BSP	
▶ Adaptadores NPT	134
Adapteurs NPT   Adaptors NPT   Adattatori NPT	
▶ Adaptadores O'Ring Boss	135
Adapteurs O'Ring Boss   O'Ring Boss Adaptors   Adattatori O'Ring Boss	
▶ Adaptadores ORFS	136
Adapteurs ORFS   Adaptors ORFS   Adattatori ORFS	

## Adaptadores BSP

Adapteurs BSP | Adaptors BSP | Adattatori BSP

Crimp fittings for hoses

Pipe fittings DIN 2353

Flare fittings JIC  
SAE flanges

Adaptors

Welding fittings

Industrial fittings

Several items

### ► Uniones rectas macho | Unions mâle | Straight adaptors male | Adattatori diritti maschio

137

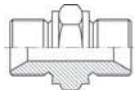

Z1010

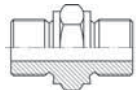

Z1011

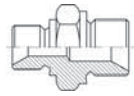

Z1020

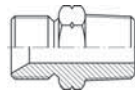

Z1014

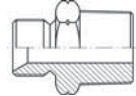

Z1012

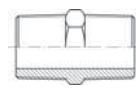

Z1016

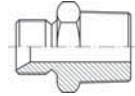

Z1022

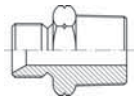

Z1024

### ► Uniones rectas macho-hembra | Unions mâle-femelle | Adaptors male-female | Adattatori diritti maschio-femmina

138



Z1060



Z1060

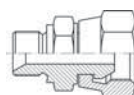

Z1173

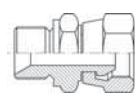

Z1170

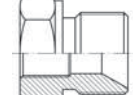

Z1150

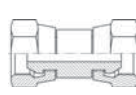

Z1172

### ► Tapones | Bouchons | Plugs | Tappi

139

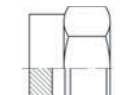

Z1072

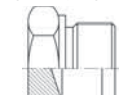

Z1070

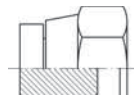

Z1075

### ► Uniones hembra y pasatabiques | Unions femelle et passe-cloison | Adaptors female and bulkheads | Raccordi femmina e di attraversamento

140



Z1310



Z1031



Z1160



Z1161

### ► Orientables | Adapteurs orientables | Banjos | Adattatori orientabili

141

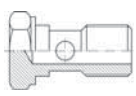

Z1090

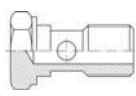

Z1092

### ► Juntas metal buna y arandelas | Bague BS | Joints | Rondelle e rondelle Bonded

141



ZVT320



ZVT210

### ► Codos accesorias | Adapteurs coude accesoiriel | Elbows | Adattatori a 90° e 45° tubolari

142



Z1194



ZA1196



Z1195



ZA1195

► **Codos en forja** | Adapteurs coude en forge | Forging elbows | Adattatori a 90° forgiati

142

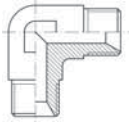

Z1190



Z1192

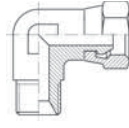

Z1193

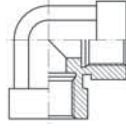

Z1196

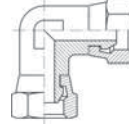

Z1198

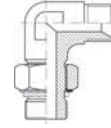

Z1197



Z1191

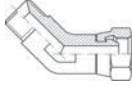

Z1183

► **TES en forja** | Adapteurs Té en forge | Forging Tees | Adattatori a T forgiati

144

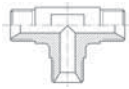

Z1220

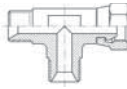

Z1222

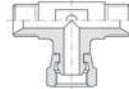

Z1224

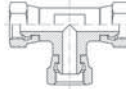

Z1228

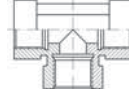

Z1226

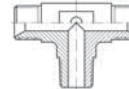

Z1221

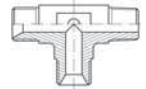

Z1223

## Adaptadores NPT

Adapteurs NPT | Adaptors NPT | Adattatori NPT

### ► Uniones rectas macho-macho | Unions mâle | Straight adaptors male | Adattatori diritti maschio - maschio

145

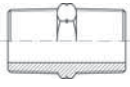

Z1015

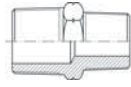

ZN1015

### ► Uniones rectas macho-hembra | Unions mâle-femelle | Adaptors male-female | Adattatori diritti maschio - femmina

145

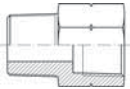

ZN1060

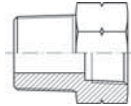

ZN1150

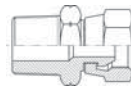

ZN1170

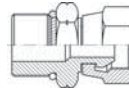

ZN1174

### ► Tapones | Bouchons | Plugs | Tappi

146

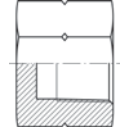

ZN1072

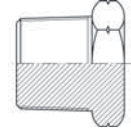

ZN1070

### ► Uniones hembra y pasatabiques | Unions femelle et passe cloisson | Adaptors female and bulkheads | Adattatori femmina e passaparete

146

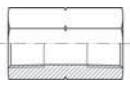

ZN1031

### ► Codos en forja | Adapteurs coude en forge | Forging elbows | Adattatori a 90° e 45° forgiati

147

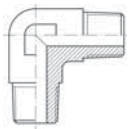

ZN1190

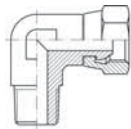

ZN1193

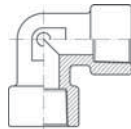

ZN1196

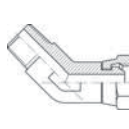

ZN1393

### ► Tes en forja | Adapteurs Té en forge | Forging tees | Adattatori a T forgiati

147

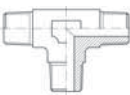

ZN1220

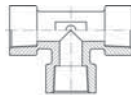

ZN1226



## Adaptadores O'Ring Boss

Adaptateurs O'Ring Boss | O'Ring Boss Adaptors | Adattatori O'Ring Boss

### ► Uniones rectas macho | Unions mâle | Straight adaptors male | Unione diritta maschio

148

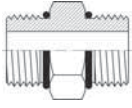

ZS6464

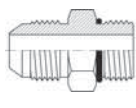

ZS220

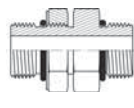

ZS3474

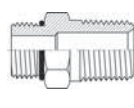

ZS6401

### ► Uniones rectas macho-hembra | Unions mâle-femelle | Adaptors male-female | Unione diritta maschio-femmina

148

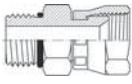

ZS380

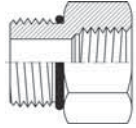

ZS6405

### ► Tapones | Bouchons | Plugs | Tappi

149

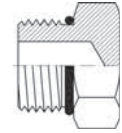

ZS6408

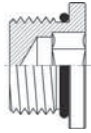

ZS6409

### ► Codos y Tes en forja | Adaptateurs coude et té en forge | Forging elbows and tees | Curve e T forgiati

149

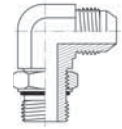

ZS575

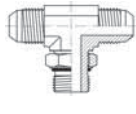

ZS6803

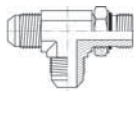

ZS6804

## Adaptadores ORFS

Adaptateurs ORFS | Adaptors ORFS | Adattatori ORFS

### ▶ **Tuercas, conos y tapones ORFS** | Écrous, collets et bouchons ORFS | ORFS Nuts, nipples and plugs | Dados, Ogive e Tappi 152

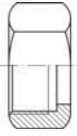

ZOR102

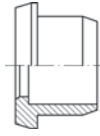

ZOR1273



ZOR104

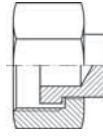

ZOR105

### ▶ **Uniones rectas ORFS** | Unions droites ORFS | ORFS Straight unions | Adattatori diritti ORFS 152

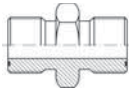

ZOR200

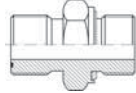

ZOR202

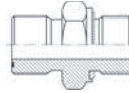

ZOR1017

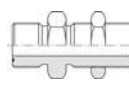

ZOR106

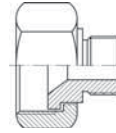

ZOR301

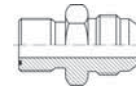

ZOR204

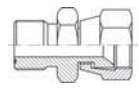

ZOR302

### ▶ **Codos ORFS** | Coudes ORFS | ORFS Elbows | Adattatori a 90° ORFS 154

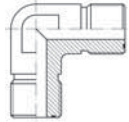

ZOR405

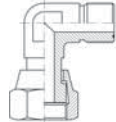

ZOR600

### ▶ **Tes ORFS** | Tés ORFS | ORFS Tees | Adattatori a T ORFS 154

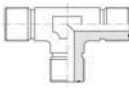

ZOR700



ZOR701

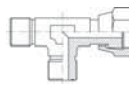

ZOR702

## Adaptadores BSP

Adaptateurs BSP  
Adaptors BSP  
Adattatori BSP

### Adaptador macho - macho BSP cono 60°

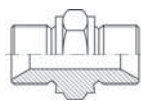

Adaptateur mâle BSP - mâle BSP cone 60°

Adaptor male BSP 60° - male BSP 60°

Niples di giunzione BSP 60°

ROSCA THREAD		REFERENCIA PART N°	€
1/8" BSP	1/8" BSP	Z101002	
1/4" BSP	1/4" BSP	Z101004	
1/4" BSP	1/4" BSP	Z101004H19	
3/8" BSP	3/8" BSP	Z101006	
1/2" BSP	1/2" BSP	Z101008	
5/8" BSP	5/8" BSP	Z101010	
3/4" BSP	3/4" BSP	Z101012	
1" BSP	1" BSP	Z101016	
1"1/4 BSP	1"1/4 BSP	Z101020	
1"1/2 BSP	1"1/2 BSP	Z101024	
2" BSP	2" BSP	Z101032	
2" BSP	2" BSP	Z101032 H70	

### Adaptador macho - macho BSP asiento plano

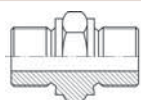

Adaptateur mâle BSP - mâle BSP fond plat

Adaptor male BSP - male BSP flat seat

Niples di giunzione BSP sede piana

ROSCA THREAD		REFERENCIA PART N°	€
1/4 BSP	1/4 BSP	Z101104	
3/8 BSP	3/8 BSP	Z101106	
1/2 BSP	1/2 BSP	Z101108	
3/4 BSP	3/4 BSP	Z101112	
1" BSP	1" BSP	Z101116	
1"1/4 BSP	1"1/4 BSP	Z101120	
1"1/2 BSP	1"1/2 BSP	Z101124	
2" BSP	2" BSP	Z101132	

### Reductor macho - macho BSP cono 60°

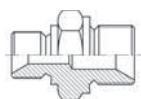

Réducteur mâle BSP - mâle BSP cone 60°

Reducer adaptor male BSP 60° - male BSP 60°

Niples di riduzione BSP 60°

ROSCA THREAD		REFERENCIA PART N°	€
1/8" BSP	1/4" BSP	Z10200204	
1/8" BSP	1/4" BSP	Z10200204 H19	
1/8" BSP	3/8" BSP	Z10200206	
1/4" BSP	3/8" BSP	Z10200406	
1/4" BSP	1/2" BSP	Z10200408	
1/4" BSP	3/4" BSP	Z10200412	
3/8" BSP	1/2" BSP	Z10200608	
3/8" BSP	3/4" BSP	Z10200612	
1/2" BSP	3/4" BSP	Z10200812	
1/2" BSP	1" BSP	Z10200816	
5/8" BSP	1/2" BSP	Z10201008	
5/8" BSP	3/4" BSP	Z10201012	
3/4" BSP	1" BSP	Z10201216	
3/4" BSP	1"1/4 BSP	Z10201220	
1" BSP	1"1/4 BSP	Z10201620	
1" BSP	1"1/2 BSP	Z10201624	
1"1/4 BSP	1"1/2 BSP	Z10202024	
1"1/4 BSP	2" BSP	Z10202032	
1"1/2 BSP	2" BSP	Z10202432	
1"1/2 BSP	2" BSP	Z10202432 H70	

### Adaptador macho BSP 60° - macho NPT

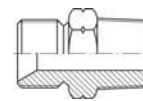

Adaptateur mâle BSP cone 60° - mâle BRIGGS (NPT)

Adaptor male BSP 60° - male NPT

Niples di congiunzione BSP 60° - NPT

ROSCA THREAD		REFERENCIA PART N°	€
1/8" BSP	1/8" NPT	Z101402	
1/4" BSP	1/4" NPT	Z101404	
3/8" BSP	3/8" NPT	Z101406	
1/2" BSP	1/2" NPT	Z101408	
3/4" BSP	3/4" NPT	Z101412	
1" BSP	1" NPT	Z101416	
1"1/4 BSP	1"1/4 NPT	Z101420	
1"1/2 BSP	1"1/2 NPT	Z101424	
2" BSP	2" NPT	Z101432	

### Adaptador macho BSP 60° - macho BSPT

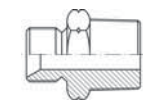

Adaptateur mâle BSP cone 60° - mâle gaz conique BSPT

Adaptor male BSP 60° - male BSPT

Niples di congiunzione BSP 60° - BSPT

ROSCA THREAD		REFERENCIA PART N°	€
1/8" BSP	1/8" BSPT	Z101202	
1/4" BSP	1/4" BSPT	Z101204	
3/8" BSP	3/8" BSPT	Z101206	
1/2" BSP	1/2" BSPT	Z101208	
3/4" BSP	3/4" BSPT	Z101212	
1" BSP	1" BSPT	Z101216	
1"1/4 BSP	1"1/4 BSPT	Z101220	
1"1/2 BSP	1"1/2 BSPT	Z101224	
2" BSP	2" BSPT	Z101232	

### Adaptador macho - macho BSPT

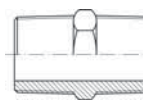

Adaptor mâle gaz conique BSPT - mâle gaz conique BSPT

Adaptor male BSPT - male BSPT

Niples di congiunzione BSPT

ROSCA THREAD		REFERENCIA PART N°	€
1/4" BSPT	1/4" BSPT	Z10160404	
3/8" BSPT	3/8" BSPT	Z10160606	
1/2" BSPT	1/2" BSPT	Z10160808	
3/4" BSPT	3/4" BSPT	Z10161212	
1" BSPT	1" BSPT	Z10161616	
1" 1/4 BSPT	1" 1/4 BSPT	Z10162020	
1" 1/2 BSPT	1" 1/2 BSPT	Z10162424	
2" BSPT	2" BSPT	Z10163232	

## Adaptadores BSP

Adaptateurs BSP  
Adaptors BSP  
Adattatori BSP

Crimp fittings for hoses

Pipe fittings DIN 2353

Flare fittings JIC  
SAE flanges

Adaptors

Welding fittings

Industrial fittings

Several items

### Reductor macho BSP 60° - macho BSPT

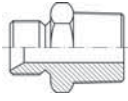

Réducteur mâle BSP cone 60° - mâle gaz conique BSPT  
Reducer adaptor male BSP 60° - male BSPT  
Niples di riduzione BSP 60° - BSPT

ROSCA THREAD		REFERENCIA PART N°	€
1/8" BSP	1/4" BSPT	Z10220204	
1/4" BSP	1/8" BSPT	Z10220402	
1/4" BSP	3/8" BSPT	Z10220406	
1/4" BSP	1/2" BSPT	Z10220408	
1/4" BSP	3/4" BSPT	Z10220412	
3/8" BSP	1/2" BSPT	Z10220608	
3/8" BSP	3/4" BSPT	Z10220612	
1/2" BSP	1/4" BSPT	Z10220804	
1/2" BSP	3/8" BSPT	Z10220806	
1/2" BSP	3/4" BSPT	Z10220812	
1/2" BSP	1" BSPT	Z10220816	
5/8" BSP	3/4" BSPT	Z10221012	
3/4" BSP	1/4" BSPT	Z10221204	
3/4" BSP	3/8" BSPT	Z10221206	
3/4" BSP	1/2" BSPT	Z10221208	
3/4" BSP	1" BSPT	Z10221216	
1" BSP	3/4" BSPT	Z10221612	
1" BSP	1"1/4 BSPT	Z10221620	
1"1/4 BSP	1" BSPT	Z10222016	
1"1/4 BSP	1"1/2 BSPT	Z10222024	
1 1/2" BSP	1 1/4" BSPT	Z10222420	
1"1/2 BSP	2" BSPT	Z10222432	

### Reductor macho BSP 60° - macho NPT

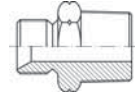

Réducteur mâle BSP cone 60° - mâle BRIGGS NPT  
Reducer adaptor male BSP 60° - male NPT  
Niples di riduzione BSP 60° - NPT

ROSCA THREAD		REFERENCIA PART N°	€
1/8" BSP	1/4" NPT	Z10240204	
1/4" BSP	1/8" NPT	Z10240402	
1/4" BSP	3/8" NPT	Z10240406	
1/4" BSP	1/2" NPT	Z10240408	
3/8" BSP	1/4" NPT	Z10240604	
3/8" BSP	1/2" NPT	Z10240608	
3/8" BSP	3/4" NPT	Z10240612	
1/2" BSP	3/8" NPT	Z10240806	
1/2" BSP	3/4" NPT	Z10240812	
5/8" BSP	3/4" NPT	Z10241012	
3/4" BSP	1/4" NPT	Z10241204	
3/4" BSP	3/8" NPT	Z10241206	
3/4" BSP	1/2" NPT	Z10241208	
3/4" BSP	1" NPT	Z10241216	
3/4" BSP	1" 1/4 NPT	Z10241220	
3/4" BSP	1"1/2 NPT	Z10241224	
1" BSP	1/2" NPT	Z10241608	
1" BSP	3/4" NPT	Z10241612	
1" BSP	1"1/4 NPT	Z10241620	
1" 1/4 BSP	1" NPT	Z10242016	
1"1/4 BSP	1"1/2 NPT	Z10242024	
1" 1/2 BSP	1" 1/4 NPT	Z10242420	
1"1/2 BSP	2" NPT	Z10242432	
2" BSP	1" 1/2 NPT	Z10243224	

### Prolongador macho BSP 60° - hembra fija BSP

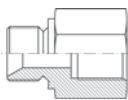

Prolongateur mâle BSP cone 60° - femelle gaz fixe  
Adaptor male BSP 60° - fixed female BSP  
Prolunga maschio - femmina BSP 60°

ROSCA THREAD		REFERENCIA PART N°	€
M 1/8" BSP	H 1/8" BSP	Z106002	
M 1/4" BSP	H 1/4" BSP	Z106004	
M 3/8" BSP	H 3/8" BSP	Z106006	
M 1/2" BSP	H 1/2" BSP	Z106008	
M 3/4" BSP	H 3/4" BSP	Z106012	
M 1" BSP	H 1" BSP	Z106016	
M 1"1/4 BSP	H 1"1/4 BSP	Z106020	
M 1"1/2 BSP	H 1"1/2 BSP	Z106024	
M 2" BSP	H 2" BSP	Z106032	

### Reductor macho BSP 60° - hembra fija BSP

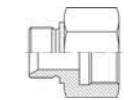

Prolongateur réducteur mâle BSP cone 60° - femelle gaz  
Reducer adaptor male BSP 60° - fixed female BSP  
Prolunga di riduzione maschio - femmina BSP 60°

ROSCA THREAD		REFERENCIA PART N°	€
M 1/8" BSP	H 1/4" BSP	Z10600204	
M 1/8" BSP	H 3/8" BSP	Z10600206	
M 1/4" BSP	H 1/8" BSP	Z10600402	
M 1/4" BSP	H 3/8" BSP	Z10600406	
M 1/4" BSP	H 1/2" BSP	Z10600408	
M 3/8" BSP	H 1/4" BSP	Z10600604	
M 3/8" BSP	H 1/2" BSP	Z10600608	
M 1/2" BSP	H 1/4" BSP	Z10600804	
M 1/2" BSP	H 3/8" BSP	Z10600806	
M 1/2" BSP	H 3/4" BSP	Z10600812	
M 3/4" BSP	H 3/8" BSP	Z10601206	
M 3/4" BSP	H 1/2" BSP	Z10601208	
M 3/4" BSP	H 1" BSP	Z10601216	
M 1" BSP	H 3/4" BSP	Z10601612	
M 1" BSP	H 1"1/4 BSP	Z10601620	
M 1"1/4 BSP	H 1" BSP	Z10602016	
M 1"1/2 BSP	H 1"1/4 BSP	Z10602420	
M 1"1/2 BSP	H 2" BSP	Z10602432	
M 2" BSP	H 1"1/2 BSP	Z10603224	

## Adaptadores BSP

Adapteurs BSP  
Adaptors BSP  
Adattatori BSP

### Reductor macho - hembra giratoria BSP cono 60°

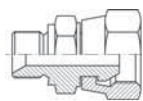

Réducteur mâle BSP - femelle tournante BSP cono 60°

Reducer male BSP 60° - swivel female BSP 60°

Nipples di riduzione maschio - femmina girevole BSP 60°

ROSCA THREAD		REFERENCIA PART N°	€
M 1/8" BSP	H 1/4" BSP	Z11730204	
M 1/4" BSP	H 3/8" BSP	Z11730406	
M 3/8" BSP	H 1/2" BSP	Z11730608	
M 1/2" BSP	H 3/8" BSP	Z11730806	
M 1/2" BSP	H 3/4" BSP	Z11730812	
M 3/4" BSP	H 1" BSP	Z11731216	
M 1" BSP	H 3/4" BSP	Z11731612	
M 1" BSP	H 1 1/4" BSP	Z11731620	
M 1 1/4" BSP	H 1" BSP	Z11732016	
M 1 1/4" BSP	H 1 1/2" BSP	Z11732024	
M 1 1/2" BSP	H 1 1/4" BSP	Z11732420	
M 1 1/2" BSP	H 2" BSP	Z11732432	
M 2" BSP	H 1 1/2" BSP	Z11733224	

### Adaptador macho - hembra giratoria BSP cono 60°

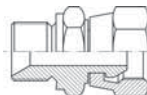

Adapteur mâle BSP - femelle tournante BSP cono 60°

Adaptor male BSP 60° - swivel female BSP 60°

Nipples maschio - femmina girevole BSP 60°

ROSCA THREAD		REFERENCIA PART N°	€
M 1/4" BSP	H 1/4" BSP	Z117004	
M 3/8" BSP	H 3/8" BSP	Z117006	
M 1/2" BSP	H 1/2" BSP	Z117008	
M 3/4" BSP	H 3/4" BSP	Z117012	
M 1" BSP	H 1" BSP	Z117016	
M 1 1/4" BSP	H 1 1/4" BSP	Z117020	
M 1 1/2" BSP	H 1 1/2" BSP	Z117024	
M 2" BSP	H 2" BSP	Z117032	

### Tapón hembra hexagonal rosca BSP



Bouchon femelle gaz  
BSP fixed female plug  
Tappo femmina fissa BSP

ROSCA THREAD	REFERENCIA PART N°	€
1/4" BSP	Z107204	
3/8" BSP	Z107206	
1/2" BSP	Z107208	
3/4" BSP	Z107212	
1" BSP	Z107216	
1 1/4" BSP	Z107220	
1 1/2" BSP	Z107224	
2" BSP	Z107232	

### Tapón reductor macho BSP 60° - hembra fija BSP



Bouchon réducteur mâle BSP cono 60° - femelle gaz

Reducer plug male BSP 60° - fixed female BSP

Tappo di riduzione maschio - femmina BSP 60°

ROSCA THREAD		REFERENCIA PART N°	€
M 1/4" BSP	H 1/8" BSP	Z11500402	
M 3/8" BSP	H 1/8" BSP	Z11500602	
M 3/8" BSP	H 1/4" BSP	Z11500604	
M 1/2" BSP	H 1/4" BSP	Z11500804	
M 1/2" BSP	H 3/8" BSP	Z11500806	
M 3/4" BSP	H 1/2" BSP	Z11501208	
M 1" BSP	H 1/2" BSP	Z11501608	
M 1" BSP	H 3/4" BSP	Z11501612	
M 1 1/4" BSP	H 3/4" BSP	Z11502012	
M 1 1/4" BSP	H 1" BSP	Z11502016	
M 1 1/2" BSP	H 1" BSP	Z11502416	
M 2" BSP	H 1" BSP	Z11503216	
M 2" BSP	H 1 1/4" BSP	Z11503220	
M 2" BSP	H 1 1/2" BSP	Z11503224	

### Adaptador hembra giratoria - hembra giratoria BSP 60°

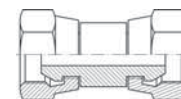

Adapteur femelle tournante BSP 60° - femelle tournante BSP 60°

Adaptor BSP 60° swivel female - BSP 60° swivel female

Nipples femmina - femmina girevole BSP 60°

ROSCA THREAD		REFERENCIA PART N°	€
1/4" BSP	1/4" BSP	Z117204	
3/8" BSP	3/8" BSP	Z117206	
1/2" BSP	1/2" BSP	Z117208	
3/4" BSP	3/4" BSP	Z117212	
1" BSP	1" BSP	Z117216	
1 1/2" BSP	1 1/2" BSP	Z117224	

### Tapón macho hexagonal rosca BSP 60°



Bouchon mâle BSP cono 60°  
BSP male hexagonal plug  
Tappo maschio esagonale BSP

ROSCA THREAD	REFERENCIA PART N°	€
1/8" BSP	Z107002	
1/4" BSP	Z107004	
3/8" BSP	Z107006	
1/2" BSP	Z107008	
3/4" BSP	Z107012	
1" BSP	Z107016	
1 1/4" BSP	Z107020	
1 1/2" BSP	Z107024	
2" BSP	Z107032	

## Adaptadores BSP

Adaptateurs BSP  
Adaptors BSP  
Adattatori BSP

Crimp fittings for hoses

Pipe fittings DIN 2353

Flare fittings JIC  
SAE flanges

Adaptors

Welding fittings

Industrial fittings

Several items

### Tapón hembra giratoria BSP cono 60°



Bouchon femelle tournante BSP cone 60°

BSP swivel female plug

Tappo femmina girevole BSP

ROSCA THREAD	REFERENCIA PART N°	€
1/4" BSP	Z107504	
3/8" BSP	Z107506	
1/2" BSP	Z107508	
3/4" BSP	Z107512	
1" BSP	Z107516	
1" 1/4 BSP	Z107520	
1" 1/2 BSP	Z107524	
2" BSP	Z107532	

### Manguito redondo roscado hembra BSP



Manchon femelle gaz ronde

Adaptor female fixed BSP - female fixed BSP

Manicoto femmina - femmina BSP

ROSCA THREAD	REFERENCIA PART N°	€
1/8" BSP	Z131002	
1/4" BSP	Z131004	
3/8" BSP	Z131006	
1/2" BSP	Z131008	
3/4" BSP	Z131012	
1" BSP	Z131016	
1" 1/4 BSP	Z131020	
1" 1/2 BSP	Z131024	
2" BSP	Z131032	

### Pasatabiques sin tuerca BSP cono 60°

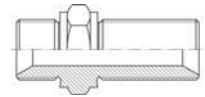

Passe-cloison mâle BSP 60° - mâle BSP 60° sans équiper

Straight bulkhead adaptor BSP 60° without nut

Niples passaparete BSP 60°

ROSCA THREAD	REFERENCIA PART N°	€
1/4" BSP	Z116004	
3/8" BSP	Z116006	
1/2" BSP	Z116008	
3/4" BSP	Z116012	
1" BSP	Z116016	
1" 1/4 BSP	Z116020	
1" 1/2 BSP	Z116024	
2" BSP	Z116032	

### Manguito hexagonal roscado hembra BSP



Manchon femelle gaz - femelle gaz hexagone

Adaptor hexagonal female fixed BSP - female fixed BSP

Prolunga esagonale femmina - femmina BSP

ROSCA THREAD	REFERENCIA PART N°	€
1/4" BSP	Z103104	
3/8" BSP	Z103106	
1/2" BSP	Z103108	
3/4" BSP	Z103112	
1" BSP	Z103116	
1" 1/4 BSP	Z103120	
1" 1/2 BSP	Z103124	

### Tuerca pasatabiques BSP

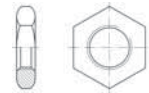

Contre-écrou passe-cloison gaz

Conter nut for BSP bulkhead

Controdado per passaparete

ROSCA THREAD	REFERENCIA PART N°	€
1/4" BSP	Z116104	
3/8" BSP	Z116106	
1/2" BSP	Z116108	
3/4" BSP	Z116112	
1" BSP	Z116116	
1" 1/4 BSP	Z116120	
1" 1/2 BSP	Z116124	
2" BSP	Z116132	

## Adaptadores BSP

Adaptateurs BSP  
Adaptors BSP  
Adattatori BSP

### Tornillo orientable simple BSP

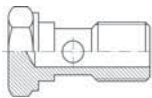

Vis creuse simple pour banjo gaz  
BSP Bolt for banjo  
Bullone forato BSP

ROSCA THREAD	REFERENCIA PART N°	€
1/4" BSP	Z109004	
3/8" BSP	Z109006	
1/2" BSP	Z109008	
3/4" BSP	Z109012	
1" BSP	Z109016	

### Tornillo orientable simple Métrico

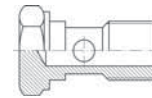

Vis creuse simple for banjo Métrique  
Metric bolt for banjo  
Bullone forato Metrico

ROSCA THREAD	REFERENCIA PART N°	€
M12X1.5	Z109212	
M14X1.5	Z109214	
M16X1.5	Z109216	
M18X1.5	Z109218	
M22X1.5	Z109222	
M26X1.5	Z109226	
M30X1.5	Z109230	

### Juntas metal Buna FKM Métricas



Bague BS Métrique FKM  
Metric Bonded Seal in FKM  
Rondella Bonded FKM Metriche

ROSCA THREAD	REFERENCIA PART N°	€
M8X1	ZVT32008	
M12X1,5	ZVT32012	
M14X1,5	ZVT32014	
M16X1,5	ZVT32016	
M18X1,5	ZVT32018	
M22X1,5	ZVT32022	

### Juntas metal Buna FKM Gas



Bague BS gaz FKM  
Gas Bonded Seal FKM  
Rondella Bonded FKM Gas

ROSCA THREAD	REFERENCIA PART N°	€
1/8" BSP	ZVT21002	
1/4" BSP	ZVT21004	
3/8" BSP	ZVT21006	
1/2" BSP	ZVT21008	
5/8" BSP	ZVT21010	
3/4" BSP	ZVT21012	
1" BSP	ZVT21016	
1" 1/4 BSP	ZVT21020	
1" 1/2 BSP	ZVT21024	
2"	ZVT21032	

Crimp fittings for hoses

Pipe fittings DIN 2353

Flare fittings JIC  
SAE flanges

Adaptors

Welding fittings

Industrial fittings

Several items

## Adaptadores BSP

Adapteurs BSP  
Adaptors BSP  
Adattatori BSP

Crimp fittings for hoses

Pipe fittings DIN 2353

Flare fittings JIC  
SAE flanges

Adaptors

Welding fittings

Industrial fittings

Several items

### Codo 90° macho - hembra giratoria BSP cono 60°



Adapteur coude 90° accesoriel mâle BSP - femelle tournante BSP cono 60°

90° Elbow swivel female BSP 60° - male BSP 60°

Curva 90° maschio - femmina girevole BSP 60°

ROSCA THREAD		REFERENCIA PART N°	€
M 1/4" BSP	H 1/4" BSP	Z119404	
M 3/8" BSP	H 3/8" BSP	Z119406	
M 1/2" BSP	H 1/2" BSP	Z119408	
M 3/4" BSP	H 3/4" BSP	Z119412	
M 1" BSP	H 1" BSP	Z119416	
M 1 1/4" BSP	H 1 1/4" BSP	Z119420	
M 1 1/2" BSP	H 1 1/2" BSP	Z119424	
M 2" BSP	H 2" BSP	Z119432	

### Codo 45° macho - hembra giratoria BSP cono 60°



Adapteur coude 45° accesoriel mâle BSP - femelle tournante BSP cono 60°

45° Elbow swivel female BSP 60° - male BSP 60°

Curva 45° maschio - femmina girevole BSP 60°

ROSCA THREAD		REFERENCIA PART N°	€
M 1/4" BSP	H 1/4" BSP	Z119504	
M 3/8" BSP	H 3/8" BSP	Z119506	
M 1/2" BSP	H 1/2" BSP	Z119508	
M 3/4" BSP	H 3/4" BSP	Z119512	
M 1" BSP	H 1" BSP	Z119516	
M 1 1/4" BSP	H 1 1/4" BSP	Z119520	
M 1 1/2" BSP	H 1 1/2" BSP	Z119524	
M 2" BSP	H 2" BSP	Z119532	

### Codo 90° hembra giratoria - hembra giratoria BSP cono 60°



Adapteur coude 90° femelle tournante BSP - femelle tournante cono 60°

90° Elbow swivel female BSP 60° - swivel female BSP 60°

Curva 90° femmina - femmina girevole BSP 60°

ROSCA THREAD		REFERENCIA PART N°	€
1/4" BSP	1/4" BSP	ZA119604	
3/8" BSP	3/8" BSP	ZA119606	
1/2" BSP	1/2" BSP	ZA119608	
3/4" BSP	3/4" BSP	ZA119612	
1" BSP	1" BSP	ZA119616	
1 1/4" BSP	1 1/4" BSP	ZA119620	

### Codo 45° hembra giratoria - hembra giratoria BSP cono 60°



Adapteur coude 45° femelle tournante BSP - femelle tournante BSP cono 60°

45° Elbow swivel female BSP 60° - swivel female BSP 60°

Curva 45° femmina girevole - femmina girevole BSP 60°

ROSCA THREAD		REFERENCIA PART N°	€
1/4" BSP	1/4" BSP	ZA119504	
3/8" BSP	3/8" BSP	ZA119506	
1/2" BSP	1/2" BSP	ZA119508	
3/4" BSP	3/4" BSP	ZA119512	
1" BSP	1" BSP	ZA119516	
1 1/4" BSP	1 1/4" BSP	ZA119520	

### Codo 90° macho - macho BSP cono 60°



Adapteur coude 90° mâle BSP - mâle BSP cono 60° forge

90° Adaptor male - male BSP 60°

Adattatore a 90° maschio - maschio BSP 60°

ROSCA THREAD		REFERENCIA PART N°	€
1/8" BSP	1/8" BSP	Z1190002	
1/4" BSP	1/4" BSP	Z1190004	
3/8" BSP	3/8" BSP	Z1190006	
1/2" BSP	1/2" BSP	Z1190008	
3/4" BSP	3/4" BSP	Z1190012	
1" BSP	1" BSP	Z1190016	
1 1/4" BSP	1 1/4" BSP	Z1190020	
1 1/2" BSP	1 1/2" BSP	Z1190024	

### Codo 90° macho BSP 60° - macho BSPT



Adapteur coude 90° mâle BSP cono 60° - mâle gaz conique BSPT forge

90° Adaptor male BSP 60° - male BSPT

Adattatore a 90° maschio BSP 60° - maschio BSPT

ROSCA THREAD		REFERENCIA PART N°	€
1/8" BSP	1/8" BSPT	Z119202	
1/4" BSP	1/4" BSPT	Z119204	
3/8" BSP	3/8" BSPT	Z119206	
1/2" BSP	1/2" BSPT	Z119208	
3/4" BSP	3/4" BSPT	Z119212	
1" BSP	1" BSPT	Z119216	
1 1/4" BSP	1 1/4" BSPT	Z119220	
1 1/2" BSP	1 1/2" BSPT	Z119224	



## Adaptadores BSP

Adaptateurs BSP  
Adaptors BSP  
Adattatori BSP

### Codo 90° macho - hembra giratoria BSP 60°



Adaptateur coude 90° mâle BSP - femelle tournante BSP cone 60° forge  
90° Adaptor male - swivel female BSP 60°  
Adattatore a 90° maschio - femmina girevole BSP 60°

ROSCA THREAD		REFERENCIA PART N°	€
M 1/8" BSP	H 1/8" BSP	Z119302	
M 1/4" BSP	H 1/4" BSP	Z119304	
M 3/8" BSP	H 3/8" BSP	Z119306	
M 1/2" BSP	H 1/2" BSP	Z119308	
M 3/4" BSP	H 3/4" BSP	Z119312	
M 1" BSP	H 1" BSP	Z119316	
M 1 1/4" BSP	H 1 1/4" BSP	Z119320	
M 1 1/2" BSP	H 1 1/2" BSP	Z119324	

### Codo 90° regulable macho - macho BSP



Coude 90° orientable mâle - mâle BSP  
90° Adjustable stud elbow male-male BSP  
Adattatore a 90° orientabile maschio - maschio BSP

ROSCA THREAD		REFERENCIA PART N°	€
1/4" BSP	1/4" BSP	Z119704	
3/8" BSP	3/8" BSP	Z119706	
1/2" BSP	1/2" BSP	Z119708	
3/4" BSP	3/4" BSP	Z119712	
1" BSP	1" BSP	Z119716	

### Codo 90° hembra fija - hembra fija BSP

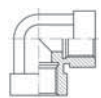

Adaptateur coude 90° femelle fixe gaz cylindrique forge  
90° Adaptor fixed female BSP  
Adattatore a 90° femmina fissa BSP

ROSCA THREAD		REFERENCIA PART N°	€
1/8" BSP	1/8" BSP	Z119602	
1/4" BSP	1/4" BSP	Z119604	
3/8" BSP	3/8" BSP	Z119606	
1/2" BSP	1/2" BSP	Z119608	
3/4" BSP	3/4" BSP	Z119612	
1" BSP	1" BSP	Z119616	

### Codo 90° macho BSP 60° - macho NPT



Adaptateur coude 90° mâle BSP 60° - mâle NPT forge  
90° Adaptor male BSP 60° - male NPT  
Adattatore a 90° maschio BSP 60° - maschio NPT

ROSCA THREAD		REFERENCIA PART N°	€
1/4" BSP	1/4" NPT	Z11910404	
3/8" BSP	3/8" NPT	Z11910606	
1/2" BSP	1/2" NPT	Z11910808	
3/4" BSP	3/4" NPT	Z11911212	
1" BSP	1" NPT	Z11911616	

### Codo 90° hembra giratoria - hembra giratoria BSP 60°



Adaptateur coude 90° femelle tournante BSP cone 60° forge  
90° Adaptor swivel female BSP 60°  
Adattatore a 90° femmina girevole BSP 60°

ROSCA THREAD		REFERENCIA PART N°	€
1/4" BSP	1/4" BSP	Z119804	
3/8" BSP	3/8" BSP	Z119806	
1/2" BSP	1/2" BSP	Z119808	
3/4" BSP	3/4" BSP	Z119812	
1" BSP	1" BSP	Z119816	
1 1/4" BSP	1 1/4" BSP	Z119820	
1 1/2" BSP	1 1/2" BSP	Z119824	

### Codo 45° macho - hembra giratoria BSP 60°

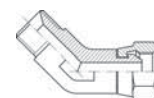

Adaptateur coude 45° mâle BSP - femelle tournante BSP cone 60° forge  
45° Adaptor male - swivel female BSP 60°  
Adattatore a 45° maschio - femmina girevole BSP 60°

ROSCA THREAD		REFERENCIA PART N°	€
M 1/4" BSP	H 1/4" BSP	Z118304	
M 3/8" BSP	H 3/8" BSP	Z118306	
M 1/2" BSP	H 1/2" BSP	Z118308	
M 3/4" BSP	H 3/4" BSP	Z118312	
M 1" BSP	H 1" BSP	Z118316	

## Adaptadores BSP

Adaptateurs BSP  
Adaptors BSP  
Adattatori BSP

### TES macho - macho - macho BSP cono 60°

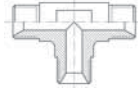

Adaptateurs Té mâle BSP cone 60° forge  
Tees BSP 60° male  
Adattatore a T maschio BSP

ROSCA THREAD			REFERENCIA PART N°	€
1/4" BSP	1/4" BSP	1/4" BSP	Z122004	
3/8" BSP	3/8" BSP	3/8" BSP	Z122006	
1/2" BSP	1/2" BSP	1/2" BSP	Z122008	
3/4" BSP	3/4" BSP	3/4" BSP	Z122012	
1" BSP	1" BSP	1" BSP	Z122016	
1"1/4 BSP	1"1/4 BSP	1"1/4 BSP	Z122020	
1"1/2 BSP	1"1/2 BSP	1"1/2 BSP	Z122024	

### TES hembras giratorias BSP cono 60°

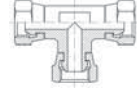

Adaptateurs Té femelle tournante BSP cone 60° forge  
Tees BSP 60° swivel female  
Adattatore a T femmina - femmina - femmina girevoli BSP

ROSCA THREAD			REFERENCIA PART N°	€
1/4" BSP	1/4" BSP	1/4" BSP	Z122804	
3/8" BSP	3/8" BSP	3/8" BSP	Z122806	
1/2" BSP	1/2" BSP	1/2" BSP	Z122808	
3/4" BSP	3/4" BSP	3/4" BSP	Z122812	
1" BSP	1" BSP	1" BSP	Z122816	
1"1/4 BSP	1"1/4 BSP	1"1/4 BSP	Z122820	
1"1/2 BSP	1"1/2 BSP	1"1/2 BSP	Z122824	

### TES hembras fijas BSP

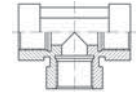

Adaptateurs Té femelle gaz forge  
Tees fixed female BSP  
Adattatore a T femmina fissa BSP

ROSCA THREAD			REFERENCIA PART N°	€
1/4" BSP	1/4" BSP	1/4" BSP	Z122604	
3/8" BSP	3/8" BSP	3/8" BSP	Z122606	
1/2" BSP	1/2" BSP	1/2" BSP	Z122608	
3/4" BSP	3/4" BSP	3/4" BSP	Z122612	
1" BSP	1" BSP	1" BSP	Z122616	

### TES macho - macho - hembra giratoria BSP 60°

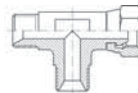

Adaptateurs Té mâle BSP - mâle BSP - femelle tournante BSP cone 60° forge  
Tees BSP 60° male - male - swivel female  
Adattatore a T maschio - maschio - femmina girevole BSP

ROSCA THREAD			REF. PART N°	€
M 1/4" BSP	M 1/4" BSP	H 1/4" BSP	Z122204	
M 3/8" BSP	M 3/8" BSP	H 3/8" BSP	Z122206	
M 1/2" BSP	M 1/2" BSP	H 1/2" BSP	Z122208	
M 3/4" BSP	M 3/4" BSP	H 3/4" BSP	Z122212	
M 1" BSP	M 1" BSP	H 1" BSP	Z122216	
M 1"1/4 BSP	M 1"1/4 BSP	H 1"1/4 BSP	Z122220	
M 1"1/2 BSP	M 1"1/2 BSP	H 1"1/2 BSP	Z122224	

### TES macho BSP 60° - macho NPT central - macho BSP 60°

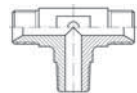

Adaptateurs Té mâle BSP 60° - mâle NPT central - mâle BSP 60° forge  
Tees BSP 60° male - NPT male center - BSP 60° male  
Adattatore a T maschio - maschio - maschio

ROSCA THREAD			REFERENCIA PART N°	€
1/2" BSP	1/2" NPT	1/2" BSP	Z12210808	
1/4" BSP	1/4" NPT	1/4" BSP	Z12210404	
3/8" BSP	3/8" NPT	3/8" BSP	Z12210606	
3/4" BSP	3/4" NPT	3/4" BSP	Z12211212	
1" BSP	1" NPT	1" BSP	Z12211616	

### TES macho - hembra giratoria - macho BSP 60°

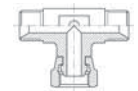

Adaptateurs Té mâle BSP - femelle tournante - mâle BSP cone 60° forge  
Tees BSP 60° male - swivel female - male  
Adattatore a T maschio - femmina girevole - maschio BSP

ROSCA THREAD			REF. PART N°	€
M 1/4" BSP	H 1/4" BSP	M 1/4" BSP	Z122404	
M 3/8" BSP	H 3/8" BSP	M 3/8" BSP	Z122406	
M 1/2" BSP	H 1/2" BSP	M 1/2" BSP	Z122408	
M 3/4" BSP	H 3/4" BSP	M 3/4" BSP	Z122412	
M 1" BSP	H 1" BSP	M 1" BSP	Z122416	
M 1"1/4 BSP	H 1"1/4 BSP	M 1"1/4 BSP	Z122420	
M 1"1/2 BSP	H 1"1/2 BSP	M 1"1/2 BSP	Z122424	

### TES macho BSP 60° - macho BSP 60° - macho NPT lateral

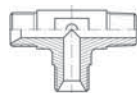

Adaptateurs Té mâle BSP 60° - mâle BSP 60° - mâle NPT latéral forge  
Tees BSP 60° male - BSP 60° male - NPT male side  
Adattatore a T maschio - maschio - maschio

ROSCA THREAD			REFERENCIA PART N°	€
1/4" BSP	1/4" BSP	1/4" NPT	Z12230404	
3/8" BSP	3/8" BSP	3/8" NPT	Z12230606	
1/2" BSP	1/2" BSP	1/2" NPT	Z12230808	
3/4" BSP	3/4" BSP	3/4" NPT	Z12231212	
1" BSP	1" BSP	1" NPT	Z12231616	

## Adaptadores NPT

Adaptateurs NPT  
Adaptors NPT  
Adattatori NPT

### Adaptor macho - macho NPT

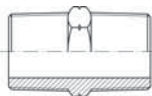

Adaptateur mâle NPT - mâle NPT

Adaptor male NPT - male NPT

Niples di congiunzione NPT

ROSCA THREAD		REFERENCIA PART N°	€
1/4" NPT	1/4" NPT	Z10150404	
3/8" NPT	3/8" NPT	Z10150606	
1/2" NPT	1/2" NPT	Z10150808	
3/4" NPT	3/4" NPT	Z10151212	
1" NPT	1" NPT	Z10151616	
1" 1/4 NPT	1" 1/4 NPT	Z10152020	
1" 1/2 NPT	1" 1/2 NPT	Z10152424	
2" NPT	2" NPT	Z10153232	

### Reductor macho - macho NPT

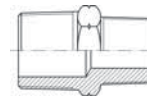

Réducteur mâle NPT - mâle NPT

Reducer male NPT - male NPT

Niples di riduzione maschio - maschio NPT

ROSCA THREAD		REFERENCIA PART N°	€
1/4" - 18h NPT	1/8" - 27h NPT	ZN10150402	
3/8" - 18h NPT	1/8" - 27h NPT	ZN10150602	
3/8" - 18h NPT	1/4" - 18h NPT	ZN10150604	
1/2" - 14h NPT	1/4" - 18h NPT	ZN10150804	
1/2" - 14h NPT	3/8" - 18h NPT	ZN10150806	
3/4" - 14h NPT	1/2" - 14h NPT	ZN10151208	
1" - 11 1/2 h NPT	3/4" - 14h NPT	ZN10151612	
1" 1/4 - 11 1/2 h NPT	1" - 11 1/2 h NPT	ZN10152016	
1" 1/2 - 11 1/2 h NPT	1" - 11 1/2 h NPT	ZN10152416	
1" 1/2 - 11 1/2 h NPT	1" 1/4 - 11 1/2 h NPT	ZN10152420	
2" - 11 1/2 h NPT	1" 1/2 - 11 1/2 h NPT	ZN10153224	

### Adaptador M - HF NPT

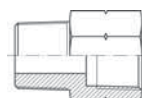

Adaptateur mâle NPT - femelle fixe NPT

Adaptor male NPT - fixed female NPT

Niples di congiunzione maschio NPT - femmina fissa NPT

ROSCA THREAD		REFERENCIA PART N°	€
M 1/8" - 27h NPT	H 1/8" - 27h NPT	ZN10600202	
M 1/8" - 27h NPT	H 1/4" - 18h NPT	ZN10600204	
M 1/4" - 18h NPT	H 1/8" - 27h NPT	ZN10600402	
M 1/4" - 18h NPT	H 1/4" - 18h NPT	ZN10600404	
M 1/4" - 18h NPT	H 3/8" - 18h NPT	ZN10600406	
M 3/8" - 18h NPT	H 1/4" - 18h NPT	ZN10600604	
M 3/8" - 18h NPT	H 3/8" - 18h NPT	ZN10600606	
M 3/8" - 18h NPT	H 1/2" - 14h NPT	ZN10600608	
M 1/2" - 14h NPT	H 3/8" - 18h NPT	ZN10600806	
M 1/2" - 14h NPT	H 1/2" - 14h NPT	ZN10600808	
M 1/2" - 14h NPT	H 3/4" - 14h NPT	ZN10600812	
M 3/4" - 14h NPT	H 1/2" - 14h NPT	ZN10601208	
M 3/4" - 14h NPT	H 3/4" - 14h NPT	ZN10601212	
M 3/4" - 14h NPT	H 1" - 11 1/2 h NPT	ZN10601216	
M 1" - 11 1/2 h NPT	H 3/4" - 14h NPT	ZN10601612	
M 1" - 11 1/2 h NPT	H 1" - 11 1/2 h NPT	ZN10601616	

### Reductor M - HF NPT

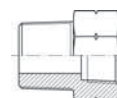

Réducteur mâle NPT - femelle fixe NPT

Reducer male NPT - fixed female NPT

Niples di riduzione maschio NPT - femmina fissa NPT

ROSCA THREAD		REFERENCIA PART N°	€
M 3/8" - 18h NPT	H 1/8" - 27h NPT	ZN11500602	
M 3/8" - 18h NPT	H 1/4" - 18h NPT	ZN11500604	
M 1/2" - 14h NPT	H 1/4" - 18h NPT	ZN11500804	
M 1/2" - 14h NPT	H 3/8" - 18h NPT	ZN11500806	
M 3/4" - 14h NPT	H 1/4" - 18h NPT	ZN11501204	
M 3/4" - 14h NPT	H 3/8" - 18h NPT	ZN11501206	
M 3/4" - 14h NPT	H 1/2" - 14h NPT	ZN11501208	
M 1" - 11 1/2 h NPT	H 3/8" - 18h NPT	ZN11501606	
M 1" - 11 1/2 h NPT	H 1/2" - 14h NPT	ZN11501608	
M 1" - 11 1/2 h NPT	H 3/4" - 14h NPT	ZN11501612	
M 1" 1/4 11 1/2 - h NPT	H 1" - 11 1/2 - h NPT	ZN11502016	
M 1" 1/2 11 1/2 - h NPT	H 1" - 11 1/2 - h NPT	ZN11502416	
M 1" 1/2 11 1/2 - h NPT	H 1" 1/4 11 1/2 - h NPT	ZN11502420	

### Adaptador M NPT - TL NPSM

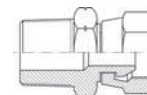

Adaptateur mâle NPT - femelle tournante NPSM

Adaptor male NPT - swivel female NPSM

Niples di congiunzione maschio NPT - femmina girevole NPSM

ROSCA THREAD		REFERENCIA PART N°	€
M 1/8" - 27h NPT	H 1/8" - 27h NPSM	ZN11700202	
M 1/4" - 18h NPT	H 1/4" - 18h NPSM	ZN11700404	
M 3/8" - 18h NPT	H 3/8" - 18h NPSM	ZN11700606	
M 3/8" - 18h NPT	H 1/2" - 14h NPSM	ZN11700608	
M 1/2" - 14h NPT	H 1/2" - 14h NPSM	ZN11700808	
M 1/2" - 14h NPT	H 3/4" - 14h NPSM	ZN11700812	
M 3/4" - 14h NPT	H 3/4" - 14h NPSM	ZN11701212	
M 1" - 11 1/2 h NPT	H 1" - 11 1/2 h NPSM	ZN11701616	
M 1" 1/4 - 11 1/2 h NPT	H 1" 1/4 - 11 1/2 h NPSM	ZN11702020	
M 1" 1/2 - 11 1/2 h NPT	H 1" 1/2 - 11 1/2 h NPSM	ZN11702424	

## Adaptadores NPT

Adaptateurs NPT  
Adaptors NPT  
Adattatori NPT

### Adaptador M UNF - TL NPSM

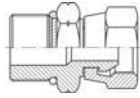

Adaptateur mâle UNF - femelle tournante NPSM

Adaptor male UNF - swivel female NPSM

Nipples di giunzione maschio UNF - femmina girevole NPSM

ROSCA THREAD		REFERENCIA PART N°	€
M 7/16" - 20h UNF	H 1/4" - 18h NPSM	<b>ZN11740404</b>	
M 9/16" - 18h UNF	H 3/8" - 18h NPSM	<b>ZN11740606</b>	
M 9/16" - 18h UNF	H 1/2" - 14h NPSM	<b>ZN11740608</b>	
M 3/4" - 16h UNF	H 1/2" - 14h NPSM	<b>ZN11740808</b>	
M 3/4" - 16h UNF	H 3/4" - 14h NPSM	<b>ZN11740812</b>	
M 7/8" - 14h UNF	H 1/2" - 14h NPSM	<b>ZN11741008</b>	
M 7/8" - 14h UNF	H 3/4" - 14h NPSM	<b>ZN11741012</b>	
M 1"1/16 - 12h UNF	H 3/4" - 14h NPSM	<b>ZN11741212</b>	
M 1"5/16 - 12h UNF	H 1" - 11 1/2h NPSM	<b>ZN11741616</b>	
M 1"5/8 - 12h UNF	H 1"1/4 - 11 1/2h NPSM	<b>ZN11742020</b>	

### Tapón HF NPT



Bouchon femelle fixe NPT

NPT fixed female plug

Tappo femmina fissa NPT

ROSCA THREAD	REFERENCIA PART N°	€
1/8" - 27h NPT	<b>ZN107202</b>	
1/4" - 18h NPT	<b>ZN107204</b>	
3/8" - 18h NPT	<b>ZN107206</b>	
1/2" - 14h NPT	<b>ZN107208</b>	
3/4" - 14h NPT	<b>ZN107212</b>	
1" - 11 1/2 h NPT	<b>ZN107216</b>	

### Tapón macho NPT



Bouchon mâle NPT

NPT male plug

Tappo maschio NPT

ROSCA THREAD	REFERENCIA PART N°	€
1/8" - 27h NPT	<b>ZN107002</b>	
1/4" - 18h NPT	<b>ZN107004</b>	
3/8" - 18h NPT	<b>ZN107006</b>	
1/2" - 14h NPT	<b>ZN107008</b>	
3/4" - 14h NPT	<b>ZN107012</b>	
1" - 11 1/2 h NPT	<b>ZN107016</b>	

### Adaptador hexagonal HF NPT

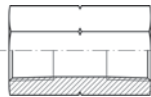

Adaptateur hexagonal femelle fixe NPT

NPT hexagonal adaptor fixed female

Adattatore esagonale femmina fissa BSP

ROSCA THREAD		REFERENCIA PART N°	€
1/8" - 27h NPT	1/8" - 27h NPT	<b>ZN10310202</b>	
1/4" - 18h NPT	1/4" - 18h NPT	<b>ZN10310404</b>	
3/8" - 18h NPT	3/8" - 18h NPT	<b>ZN10310606</b>	
1/2" - 14h NPT	1/2" - 14h NPT	<b>ZN10310808</b>	
3/4" - 14h NPT	3/4" - 14h NPT	<b>ZN10311212</b>	
1" - 11 1/2 h NPT	1" - 11 1/2 h NPT	<b>ZN10311616</b>	
1" 1/4 - 11 1/2h NPT	1" 1/4 - 11 1/2h NPT	<b>ZN10312020</b>	

## Adaptadores NPT

Adaptateurs NPT  
Adaptors NPT  
Adattatori NPT

### Codo 90° M-M NPT



Coude 90° mâle NPT - mâle NPT

90° elbow male NPT - male NPT

Adattatore a 90° maschio - maschio NPT

ROSCA THREAD		REFERENCIA PART N°	€
1/8" - 27h NPT	1/8" - 27h NPT	<b>ZN119002</b>	
1/4" - 18h NPT	1/4" - 18h NPT	<b>ZN119004</b>	
3/8" - 18h NPT	3/8" - 18h NPT	<b>ZN119006</b>	
1/2" - 14h NPT	1/2" - 14h NPT	<b>ZN119008</b>	
3/4" - 14h NPT	3/4" - 14h NPT	<b>ZN119012</b>	
1" - 11 1/2 h NPT	1" - 11 1/2 h NPT	<b>ZN119016</b>	

### Codo 90° HF-HF NPT



Coude 90° femelle fixe NPT - femelle fixe NPT

90° elbow fixed female NPT - fixed female NPT

Adattatore a 90° femmina fissa - femmina fissa NPSM

ROSCA THREAD		REFERENCIA PART N°	€
1/8" - 27h NPT	1/8" - 27h NPT	<b>ZN11960202</b>	
1/4" - 18h NPT	1/4" - 18h NPT	<b>ZN11960404</b>	
3/8" - 18h NPT	3/8" - 18h NPT	<b>ZN11960606</b>	
1/2" - 14h NPT	1/2" - 14h NPT	<b>ZN11960808</b>	
3/4" - 14h NPT	3/4" - 14h NPT	<b>ZN11961212</b>	
1" - 11 1/2 h NPT	1" - 11 1/2 h NPT	<b>ZN11961616</b>	

### Codo 90° M NPT - TL NPSM



Coude 90° mâle NPT - femelle tournante NPSM

90° elbow male NPT - swivel female NPSM

Adattatore a 90° maschio NPT - femmina girevole NPSM

ROSCA THREAD		REFERENCIA PART N°	€
M 1/8" - 27h NPT	H 1/8" 27h NPSM	<b>ZN11930202</b>	
M 1/4" - 18h NPT	H 1/4" - 18h NPSM	<b>ZN11930404</b>	
M 1/4" - 18h NPT	H 3/8" - 18h NPSM	<b>ZN11930406</b>	
M 3/8" - 18h NPT	H 3/8" - 18h NPSM	<b>ZN11930606</b>	
M 3/8" - 18h NPT	H 1/2" - 14h NPSM	<b>ZN11930608</b>	
M 1/2" - 14h NPT	H 1/2" - 14 NPSM	<b>ZN11930808</b>	
M 1/2" - 14h NPT	H 3/4" - 14h NPSM	<b>ZN11930812</b>	
M 3/4" - 14h NPT	H 1/2" - 14 NPSM	<b>ZN11931208</b>	
M 3/4" - 14h NPT	H 3/4" - 14h NPSM	<b>ZN11931212</b>	
M 3/4" - 14h NPT	H 1" - 11 1/2 h NPSM	<b>ZN11931216</b>	
M 1" - 11 1/2 h NPT	H 1" - 11 1/2 h NPSM	<b>ZN11931616</b>	
M 1 1/4" - 11 1/2 h NPT	H 1 1/4" - 11 1/2 h NPSM	<b>ZN11932020</b>	

### Codo 45° M NPT - TL NPSM

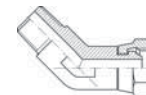

Coude 45° mâle NPT - swivel female NPSM

45° elbow male NPT - swivel female NPS

Adattatore a 45° maschio NPT - femmina girevole NPSM

ROSCA THREAD		REFERENCIA PART N°	€
M 1/4" - 18h NPT	H 1/4" - 18h NPSM	<b>ZN139304</b>	
M 3/8" - 18h NPT	H 3/8" - 18h NPSM	<b>ZN139306</b>	
M 1/2" - 14h NPT	H 1/2" - 14h NPSM	<b>ZN139308</b>	
M 3/4" - 14h NPT	H 3/4" - 14h NPSM	<b>ZN139312</b>	
M 1" - 11 1/2 h NPT	H 1" - 11 1/2 h NPSM	<b>ZN139316</b>	

### TES M-M-M NPT

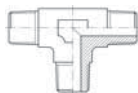

Té mâle NPT

NPT male tee

Adattatore a T maschio-maschio-maschio NPT

ROSCA THREAD			REF. PART N°	€
1/8" - 27h NPT	1/8" - 27h NPT	1/8" - 27h NPT	<b>ZN122002</b>	
1/4" - 18h NPT	1/4" - 18h NPT	1/4" - 18h NPT	<b>ZN122004</b>	
3/8" - 18h NPT	3/8" - 18h NPT	3/8" - 18h NPT	<b>ZN122006</b>	
1/2" - 14h NPT	1/2" - 14h NPT	1/2" - 14h NPT	<b>ZN122008</b>	
3/4" - 14h NPT	3/4" - 14h NPT	3/4" - 14h NPT	<b>ZN122012</b>	
1" - 11 1/2 h NPT	1" - 11 1/2 h NPT	1" - 11 1/2 h NPT	<b>ZN122016</b>	

### TES HF-HF-HF NPT

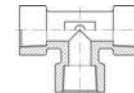

Té femelle fixe NPT

NPT fixed female tee

Adattatore a T femmina fissa-femmina fissa-femmina fissa NPT

ROSCA THREAD			REF. PART N°	€
1/8" - 27h NPT	1/8" - 27h NPT	1/8" - 27h NPT	<b>ZN122602</b>	
1/4" - 18h NPT	1/4" - 18h NPT	1/4" - 18h NPT	<b>ZN122604</b>	
3/8" - 18h NPT	3/8" - 18h NPT	3/8" - 18h NPT	<b>ZN122606</b>	
1/2" - 14h NPT	1/2" - 14h NPT	1/2" - 14h NPT	<b>ZN122608</b>	
3/4" - 14h NPT	3/4" - 14h NPT	3/4" - 14h NPT	<b>ZN122612</b>	
1" - 11 1/2 h NPT	1" - 11 1/2 h NPT	1" - 11 1/2 h NPT	<b>ZN122616</b>	

## Adaptadores O'Ring Boss

Adaptateurs O'Ring Boss  
O'Ring Boss Adaptors  
Adattatori O'Ring Boss

### Adaptador macho - macho O'Ring Boss

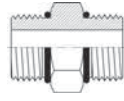

Adaptateur mâle - mâle O'Ring Boss

Adaptor male - male O'Ring Boss

Adattatore maschio-maschio o-ring Boss

TUBO PIPE		ROSCA THREAD		REFERENCIA PART N°	€
6	1/4	7/16"-20h UNF	7/16"-20h UNF	ZS64640606	
8	5/16	1/2"-20h UNF	1/2"-20h UNF	ZS64640808	
10	3/8	9/16"-18h UNF	9/16"-18h UNF	ZS64641010	
12	1/2	3/4"-16h UNF	3/4"-16h UNF	ZS64641212	
14-15-16	5/8	7/8"-14h UNF	7/8"-14h UNF	ZS64641616	
18-20	3/4	1"1/16-12h UN	1"1/16-12h UN	ZS64642020	
25	1	1"5/16-12h UN	1"5/16-12h UN	ZS64642525	

### Adaptador macho O'Ring Boss - macho regulable O'Ring Boss

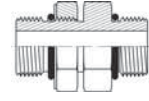

Adaptateur mâle O'Ring Boss - mâle réglable O'Ring Boss

Adaptor male O'Ring Boss - adjustable male O'Ring Boss

Adattatore maschio o-ring Boss - maschio regolabile o-ring Boss

TUBO PIPE		ROSCA THREAD		REFERENCIA PART N°	€
6	1/4	7/16"-20h UNF	7/16"-20h UNF	ZS34740606	
10	3/8	9/16"-18h UNF	9/16"-18h UNF	ZS34741010	
12	1/2	3/4"-16h UNF	3/4"-16h UNF	ZS34741212	
14-15-16	5/8	7/8"-14h UNF	7/8"-14h UNF	ZS34741616	
18-20	3/4	1"1/16-12h UN	1"1/16-12h UN	ZS34742020	
25	1	1"5/16-12h UN	1"5/16-12h UN	ZS34742525	

### Adaptador macho O'Ring Boss - macho JIC 37°

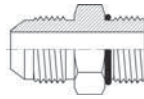

Adaptateur mâle O'Ring Boss- mâle JIC 37°

Adaptor male O'Ring Boss - male JIC 37°

Adattatore maschio o-ring Boss - maschio JIC 37°

TUBO PIPE		ROSCA THREAD		REF. PART N°	€
6	1/4	7/16"-20h UNF	7/16"-20h UNF	ZS22006	
8	5/16	1/2"-20h UNF	1/2"-20h UNF	ZS22008	
10	3/8	9/16"-18h UNF	9/16"-18h UNF	ZS22010	
12	1/2	3/4"-16h UNF	3/4"-16h UNF	ZS22012	
14-15-16	5/8	7/8"-14h UNF	7/8"-14h UNF	ZS22016	
18-20	3/4	1"1/16-12h UN	1"1/16-12h UN	ZS22020	
25	1	1"5/16-12h UN	1"5/16-12h UN	ZS22025	
30-32	1 1/4	1"5/8-12h UN	1"5/8-12h UN	ZS22032	
38	1 1/2	1"7/8-12h UN	1"7/8-12h UN	ZS22038	

### Adaptador macho O'Ring Boss - macho NPT

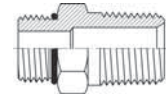

Adaptateur mâle O'Ring Boss- mâle NPT

Adaptor male O'Ring Boss - male NPT

Adattatore maschio o-ring Boss - maschio NPT

TUBO PIPE		ROSCA THREAD		REFERENCIA PART N°	€
6	1/4	7/16"-20h UNF	1/4" NPT	ZS64010613	
10	3/8	9/16"-18h UNF	3/8" NPT	ZS64011017	
12	1/2	3/4"-16h UNF	1/2" NPT	ZS64011221	
14-15-16	5/8	7/8"-14h UNF	1/2" NPT	ZS64011621	
18-20	3/4	1"1/16-12h UN	3/4" NPT	ZS64012026	
25	1	1"5/16-12h UN	1" NPT	ZS64012533	

### Adaptador macho O'Ring Boss - hembra giratoria JIC 37°

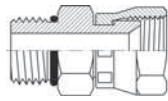

Adaptateur mâle O'Ring Boss - femelle tournante JIC 37°

Adaptor male O'Ring Boss - swivel female JIC 37°

Adattatore maschio o-ring Boss - femmina gir. JIC 37°

TUBO PIPE		ROSCA THREAD		REF. PART N°	€
6	1/4	H 7/16" 20h UNF	M 7/16" 20h UNF	ZS38006	
10	3/8	H 9/16" 18h UNF	M 9/16" 18h UNF	ZS38010	
12	1/2	H 3/4" 16h UNF	M 3/4" 16h UNF	ZS38012	
14-15-16	5/8	H 7/8" 14h UNF	M 7/8" 14h UNF	ZS38016	
18-20	3/4	H 1"1/16 12h UN	M 1"1/16 12h UN	ZS38020	
25	1	H 1"5/16 12h UN	M 1"5/16 12h UN	ZS38025	

### Prolongador macho O'Ring Boss - hembra fija NPT

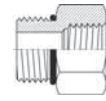

Prolongateur mâle O'Ring Boss - femelle fixe NPT

Adaptor male O'Ring Boss - fixed female NPT

Prolunga machio o-ring Boss - femmina fissa NPT

TUBO PIPE		ROSCA THREAD		REFERENCIA PART N°	€
6	1/4	7/16"-20h UNF	1/4" NPT	ZS64050613	
10	3/8	9/16"-18h UNF	3/8" NPT	ZS64051017	
12	1/2	3/4"-16h UNF	1/2" NPT	ZS64051221	
14-15-16	5/8	7/8"-14h UNF	1/2" NPT	ZS64051621	
18-20	3/4	1"1/16-12h UN	3/4" NPT	ZS64052026	
25	1	1"5/16-12h UN	1" NPT	ZS64052533	

## Adaptadores O'Ring Boss

Adaptateurs O'Ring Boss  
O'Ring Boss Adaptors  
Adattatori O'Ring Boss

### Tapón macho O'Ring Boss hexagonal

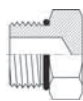

Bouchon mâle O'Ring Boss hexagonal

Male hexagonal O'Ring Boss plug

Tappo maschio o-ring Boss testa esagonale

TUBO PIPE	ROSCA THREAD	REFERENCIA PART N°	€
6	1/4	7/16" - 20h UNF	ZS640806
8	5/16	1/2" - 20h UNF	ZS640808
10	3/8	9/16" - 18h UNF	ZS640810
12	1/2	3/4" - 16h UNF	ZS640812
14-15-16	5/8	7/8" - 14h UNF	ZS640816
18-20	3/4	1" 1/16 - 12h UN	ZS640820
25	1	1" 5/16 - 12h UN	ZS640825

### Tapón macho O'Ring Boss allen



Bouchon mâle O'Ring Boss allen

Male allen O'Ring Boss plug

Tappo maschio o-ring Boss esagono incassato

TUBO PIPE	ROSCA THREAD	REFERENCIA PART N°	€
6	1/4	7/16" - 20h UNF	ZS640906
8	5/16	1/2" - 20h UNF	ZS640908
10	3/8	9/16" - 18h UNF	ZS640910
12	1/2	3/4" - 16h UNF	ZS640912
14-15-16	5/8	7/8" - 14h UNF	ZS640916
18-20	3/4	1" 1/16 - 12h UN	ZS640920
25	1	1" 5/16 - 12h UN	ZS640925

### Codo 90° regulable macho O'Ring Boss - macho JIC 37°



Coude 90° orientable mâle O'Ring Boss - mâle JIC 37°

90° Adjustable elbow male O'Ring Boss - male JIC 37°

Curva a 90° regolabile maschio o-ring Boss - maschio JIC 37°

TUBO PIPE	ROSCA THREAD	REF. PART N°	€
6	1/4	7/16 - 20h UNF	ZS57506
8	5/16	1/2 - 20h UNF	ZS57508
10	3/8	9/16 - 18h UNF	ZS57510
12	1/2	3/4 - 16h UNF	ZS57512
14-15-16	5/8	7/8 - 14h UNF	ZS57516
18-20	3/4	1 1/16 - 12h UN	ZS57520
25	1	1 5/16 - 12h UN	ZS57525

### TES regulable macho JIC 37° - macho O'Ring Boss - macho JIC 37°

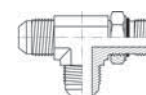

TES orientable macho JIC 37° - macho O'Ring Boss - macho JIC 37°

Adjustable Tees male JIC 37° - male O'Ring Boss - male JIC 37°

Tee regolabile maschio JIC 37° - maschio o-ring Boss - maschio JIC 37°

TUBO PIPE	ROSCA THREAD	REFERENCIA PART N°	€
6	1/4	7/16" - 20h UNF	ZS680406
8	5/16	1/2"-20h UNF	ZS680408
10	3/8	9/16" - 18h UNF	ZS680410
12	1/2	3/4" - 16h UNF	ZS680412
14-15-16	5/8	7/8" 14h UNF	ZS680416
18-20	3/4	1" 1/16-12h UN	ZS680420
25	1	1" 5/16-12h UN	ZS680425

### TES regulable macho O'Ring Boss - macho JIC 37° - macho JIC 37°

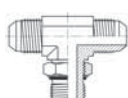

TES orientable macho O'Ring Boss - macho JIC 37° - macho JIC 37°

Adjustable Tees male O'Ring Boss - male JIC 37° - male JIC 37°

Tee regolabile maschio o-ring Boss - maschio JIC 37° - maschio JIC 37°

TUBO PIPE	ROSCA THREAD	REFERENCIA PART N°	€
6	1/4	7/16" - 20h UNF	ZS680306
8	5/16	1/2" - 20h UNF	ZS680308
10	3/8	9/16" - 18h UNF	ZS680310
12	1/2	3/4" - 16h UNF	ZS680312
14-15-16	5/8	7/8" 14h UNF	ZS680316
18-20	3/4	1" 1/16-12h UN	ZS680320
25	1	1" 5/16-12h UN	ZS680325

# Adaptadores ORFS

Adaptateurs ORFS  
Adaptors ORFS  
Adattatori ORFS

## Tuerca ORFS



Écrou ORFS  
ORFS Nut  
Dado ORFS

TUBO PIPE	ROSCA THREAD	REFERENCIA PART N°	€
6-8	ORFS 9/16"-18h	<b>ZOR1020400</b>	
10	ORFS 11/16"-16h	<b>ZOR1020600</b>	
12	ORFS 13/16"-16h	<b>ZOR1020800</b>	
14-15-16	ORFS 1"-14h	<b>ZOR1021000</b>	
18-20	ORFS 1"3/16-12h	<b>ZOR1021200</b>	
22-25	ORFS 1"7/16-12h	<b>ZOR1021600</b>	
28-30-32	ORFS 1"11/16-12h	<b>ZOR1022000</b>	
35-38	ORFS 2"-12h	<b>ZOR1022400</b>	

## Tapón macho ORFS

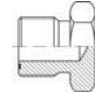

Bouchon mâle ORFS  
ORFS Male plug  
Tappo maschio ORFS

ROSCA THREAD	REFERENCIA PART N°	€
ORFS 9/16"-18h	<b>ZOR1040400</b>	
ORFS 11/16"-16h	<b>ZOR1040600</b>	
ORFS 13/16"-16h	<b>ZOR1040800</b>	
ORFS 1"-14h	<b>ZOR1041000</b>	
ORFS 1"3/16-12h	<b>ZOR1041200</b>	
ORFS 1"7/16-12h	<b>ZOR1041600</b>	
ORFS 1"11/16-12h	<b>ZOR1042000</b>	
ORFS 2"-12h	<b>ZOR1042400</b>	

## Cono soldar ORFS



Collet à souder ORFS  
ORFS Welding nipple  
Ogiva a saldare ORFS

TUBO PIPE	ROSCA THREAD	REFERENCIA PART N°	€
6	ORFS 9/16"-18h	<b>ZOR12730406</b>	
8	ORFS 9/16"-18h	<b>ZOR12730408</b>	
10	ORFS 11/16"-16h	<b>ZOR12730610</b>	
12	ORFS 13/16"-16h	<b>ZOR12730812</b>	
14	ORFS 1"-14h	<b>ZOR12731014</b>	
15	ORFS 1"-14h	<b>ZOR12731015</b>	
16	ORFS 1"-14h	<b>ZOR12731016</b>	
18	ORFS 1" 3/16-12h	<b>ZOR12731218</b>	
20	ORFS 1" 3/16-12h	<b>ZOR12731220</b>	
22	ORFS 1" 7/16-12h	<b>ZOR12731622</b>	
30	ORFS 1"11/16-12h	<b>ZOR12732030</b>	
32	ORFS 1"11/16-12h	<b>ZOR12732032</b>	
38	ORFS 2"-12h	<b>ZOR12732438</b>	

## Tapón hembra ORFS



Bouchon femelle ORFS  
ORFS Female plug  
Tappo femmina ORFS

ROSCA THREAD	REFERENCIA PART N°	€
ORFS 9/16"-18h	<b>ZOR1050400</b>	
ORFS 11/16"-16h	<b>ZOR1050600</b>	
ORFS 13/16"-16h	<b>ZOR1050800</b>	
ORFS 1"-14h	<b>ZOR1051000</b>	
ORFS 1"3/16-12h	<b>ZOR1051200</b>	
ORFS 1"7/16-12h	<b>ZOR1051600</b>	
ORFS 1"11/16-12h	<b>ZOR1052000</b>	
ORFS 2"-12h	<b>ZOR1052400</b>	

## Adaptador macho-macho ORFS

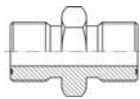

Adaptateur mâle ORFS  
ORFS Male adaptor  
Adattatore maschio ORFS

ROSCA THREAD	REFERENCIA PART N°	€
ORFS 9/16"-18h	<b>ZOR2000404</b>	
ORFS 11/16"-16h	<b>ZOR2000606</b>	
ORFS 13/16"-12h	<b>ZOR2000808</b>	
ORFS 1"-14h	<b>ZOR2001010</b>	
ORFS 1"3/16-12h	<b>ZOR2001212</b>	
ORFS 1"7/16-12h	<b>ZOR2001616</b>	
ORFS 1"11/16-12h	<b>ZOR2002020</b>	
ORFS 2"-12h	<b>ZOR2002424</b>	

## Adaptador macho ORFS- macho BSP

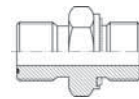

Adaptateur mâle ORFS - mâle BSP  
ORFS Male - BSP Male  
Adattatore maschio ORFS-BSP

ROSCA THREAD	REFERENCIA PART N°	€
ORFS 9/16"-18h	<b>ZOR2020404</b>	
ORFS 11/16"-16h	<b>ZOR2020606</b>	
ORFS 13/16"-16h	<b>ZOR2020808</b>	
ORFS 1"3/16-12h	<b>ZOR2021212</b>	
ORFS 1"7/16-12h	<b>ZOR2021616</b>	
ORFS 1"11/16-12h	<b>ZOR2022020</b>	
ORFS 2"-12h	<b>ZOR2022424</b>	



## Adaptadores ORFS

Adaptateurs ORFS  
Adaptors ORFS  
Adattatori ORFS

### Adaptador macho ORFS- macho Métrico

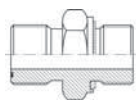

Adaptateur mâle ORFS - mâle Métrique  
ORFS Male - Metric Male  
Maschio ORFS Metrico

ROSCA THREAD		REFERENCIA PART N°	€
ORFS 9/16"-18h	M12x1.5	ZOR10170412	
ORFS 11/16"-16h	M16x1.5	ZOR10170616	
ORFS 13/16"-16h	M18x1.5	ZOR10170818	
ORFS 1"-14h	M22x1.5	ZOR10171022	
ORFS 1"7/16-12h	M33x2	ZOR10171633	
ORFS 1"11/16-12h	M42x2	ZOR10172042	
ORFS 2"-12h	M48x2	ZOR10172448	

### Pasatabiques ORFS

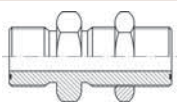

Passe-cloison ORFS  
ORFS Bulkhead  
Passaparete ORFS

ROSCA THREAD	REFERENCIA PART N°	€
ORFS 9/16"-18h	ZOR1060404	
ORFS 11/16"-16h	ZOR1060606	
ORFS 13/16"-16h	ZOR1060808	
ORFS 1"-14h	ZOR1061010	
ORFS 1"3/16-12h	ZOR1061212	
ORFS 1"7/16-12h	ZOR1061616	
ORFS 1"11/16-12h	ZOR1062020	
ORFS 2"-12h	ZOR1062424	

### Adaptador macho-hembra giratoria ORFS

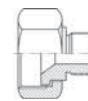

Adaptateur mâle - femelle tournante ORFS  
ORFS Male - ORFS Swivel female  
Adattatore femmina girevole ORFS-maschio ORFS

ROSCA THREAD		REFERENCIA PART N°	€
H ORFS 9/16"-18h	M ORFS 11/16"-16h	ZOR3010406	
H ORFS 11/16"-16h	M ORFS 9/16"-18h	ZOR3010604	
H ORFS 13/16"-16h	M ORFS 9/16"-18h	ZOR3010804	
H ORFS 13/16"-16h	M ORFS 11/16"-16h	ZOR3010806	
H ORFS 1"-14h	M ORFS 9/16"18h	ZOR3011004	
H ORFS 1"-14h	M ORFS 11/16"16h	ZOR3011006	
H ORFS 1"-14h	M ORFS 13/16"-16h	ZOR3011008	
H ORFS 1"3/16-12h	M ORFS 11/16"-16h	ZOR3011206	
H ORFS 1"3/16-12h	M ORFS 13/16-16h	ZOR3011208	
H ORFS 1"3/16-12h	M ORFS 1"-14h	ZOR3011210	
H ORFS 1"7/16-12h	M ORFS 13/16"-16h	ZOR3011608	
H ORFS 1"7/16-12h	M ORFS 1"-14h	ZOR3011610	
H ORFS 1"11/16-12h	M ORFS 1"3/16-12h	ZOR3012012	
H ORFS 1"11/16-12h	M ORFS 1"7/16-12h	ZOR3012016	

### Adaptador macho ORFS- macho JIC 37°

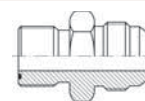

Adaptateur mâle ORFS - mâle JIC 37°  
ORFS Male - 37° JIC Male  
Adattatore maschio ORFS-JIC

ROSCA THREAD		REFERENCIA PART N°	€
ORFS 9/16"-18h	JIC 7/16"	ZOR2040404	
ORFS 11/16"-16h	JIC 9/16"	ZOR2040606	
ORFS 13/16"-16h	JIC 3/4"	ZOR2040808	
ORFS 1"-14h	JIC 7/8"	ZOR2041010	
ORFS 1"3/16-12h	JIC 1" 1/16	ZOR2041212	
ORFS 1"7/16-12h	JIC 1" 5/16	ZOR2041616	

### Adaptador macho ORFS- hembra giratoria JIC 37°

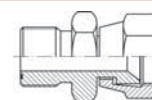

Adaptateur mâle ORFS - femelle tournante JIC 37°  
ORFS Male - 37° JIC Swivel female  
Adattatore maschio ORFS-femmina girevole JIC

ROSCA THREAD		REFERENCIA PART N°	€
ORFS 9/16"-18h	JIC 7/16"	ZOR3020404	
ORFS 11/16"-16h	JIC 9/16"	ZOR3020606	
ORFS 13/16"-16h	JIC 3/4"	ZOR3020808	
ORFS 1"-14h	JIC 7/8"	ZOR3021010	
ORFS 1"3/16-12h	JIC 1" 1/16	ZOR3021212	
ORFS 1"7/16-12h	JIC 1" 5/16	ZOR3021616	
ORFS 1"11/16-12h	JIC 1" 5/8	ZOR3022020	
ORFS 2"-12h	JIC 1" 7/8	ZOR3022424	

## Adaptadores ORFS

Adaptateurs ORFS  
Adaptors ORFS  
Adattatori ORFS

### Codo 90° macho-macho ORFS



Coude 90° mâle ORFS - mâle ORFS  
90° ORFS male - ORFS male  
Raccordo a 90° maschio ORFS-ORFS

ROSCA THREAD		REFERENCIA PART N°	€
ORFS 9/16"-18h	ORFS 9/16"-18h	ZOR4050404	
ORFS 11/16"-16h	ORFS 11/16"-16h	ZOR4050606	
ORFS 13/16"-16h	ORFS 13/16"-16h	ZOR4050808	
ORFS 1"-14h	ORFS 1"-14h	ZOR4051010	
ORFS 1"3/16-12h	ORFS 1"3/16-12h	ZOR4051212	
ORFS 1"7/16-12h	ORFS 1"7/16-12h	ZOR4051616	
ORFS 1"11/16-12h	ORFS 1"11/16-12h	ZOR4052020	
ORFS 2"-12h	ORFS 2"-12h	ZOR4052424	

### Codo 90° macho-hembra giratoria ORFS



Coude 90° femelle tournante ORFS- mâle ORFS  
90° ORFS swivel female - ORFS male  
Raccordo a 90° maschio-femmina girevole ORFS

ROSCA THREAD		REFERENCIA PART N°	€
M ORFS 9/16"-18h	H ORFS 9/16"-18h	ZOR6000404	
M ORFS 11/16"-16h	H ORFS 11/16"-16h	ZOR6000606	
M ORFS 13/16"-16h	H ORFS 13/16"-16h	ZOR6000808	
M ORFS 1"-14h	H ORFS 1"-14h	ZOR6001010	
M ORFS 1"3/16-12h	H ORFS 1"3/16-12h	ZOR6001212	
M ORFS 1"7/16-12h	H ORFS 1"7/16-12h	ZOR6001616	
M ORFS 1"11/16-12h	H ORFS 1"11/16-12h	ZOR6002020	

### TE macho-macho-macho ORFS

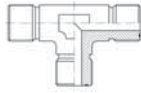

Té Mâle ORFS  
ORFS Male Tee  
Raccordo a T maschio ORFS

ROSCA THREAD	REFERENCIA PART N°	€
ORFS 9/16"-18h	ZOR7000404	
ORFS 11/16"-16h	ZOR7000606	
ORFS 13/16"-16h	ZOR7000808	
ORFS 1"-14h	ZOR7001010	
ORFS 1"3/16-12h	ZOR7001212	
ORFS 1"7/16-12h	ZOR7001616	
ORFS 1"11/16-12h	ZOR7002020	
ORFS 2"-12h	ZOR7002424	

### TE macho-hembra giratoria-macho ORFS



Té Mâle-Femelle tournante-Mâle ORFS  
ORFS Male-Swivel female-Male Tee  
Raccordo a T maschio-femmina girevole centrale-maschio ORFS

ROSCA THREAD	REFERENCIA PART N°	€
ORFS 9/16"-18h	ZOR7010404	
ORFS 11/16"-16h	ZOR7010606	
ORFS 13/16"-16h	ZOR7010808	
ORFS 1"-14h	ZOR7011010	
ORFS 1"3/16-12h	ZOR7011212	
ORFS 1"7/16-12h	ZOR7011616	
ORFS 1"11/16-12h	ZOR7012020	
ORFS 2"-12h	ZOR7012424	

### TE macho-macho-hembra giratoria ORFS

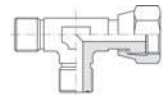

Té Mâle-Mâle-Femelle tournante ORFS  
ORFS Male-Male-Swivel Female Tee  
Raccordo a T maschio-maschio-femmina girevole laterale ORFS

ROSCA THREAD	REFERENCIA PART N°	€
ORFS 9/16"-18h	ZOR7020404	
ORFS 11/16"-16h	ZOR7020606	
ORFS 13/16"-16h	ZOR7020808	
ORFS 1"-14h	ZOR7021010	
ORFS 1"3/16-12h	ZOR7021212	
ORFS 1"7/16-12h	ZOR7021616	
ORFS 1" 11/16-12h	ZOR7022020	



Racores soldables

Raccords à souder

Welding fittings

Raccordi a saldare

▶ Racores para soldar

Raccords à souder | Welding fittings | Raccordi a saldare

154

## Racores para soldar

Raccords à souder | Welding fittings | Raccordi a saldare

### Racores macho para soldar | Raccords mâle à souder | Welding Male | Maschio a saldare

157

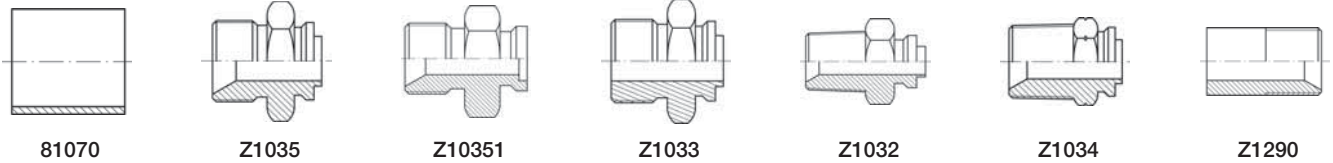

### Racores BSP para soldar | Écrous tournants à souder | Welding BSP nuts | Raccordi BSP a saldare

158

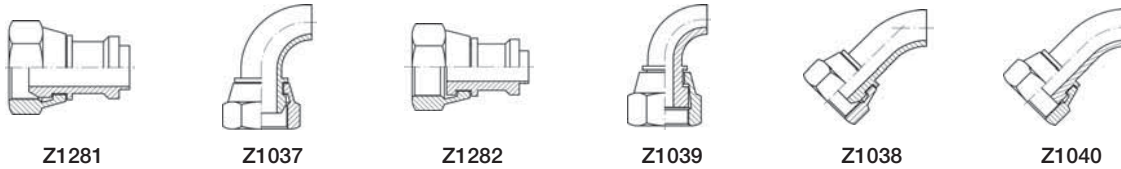

### Racores JIC para soldar | Raccords JIC à souder | Welding JIC fittings | Raccordi JIC a saldare

159

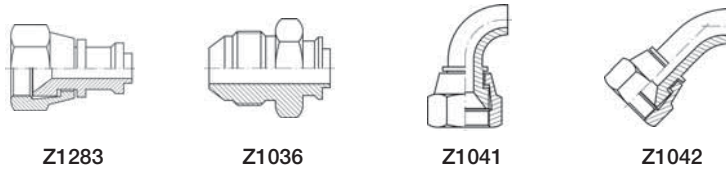

### Racores Métricos para soldar | Raccords métriques à souder | Welding metric fittings | Raccordi metrici a saldare

160

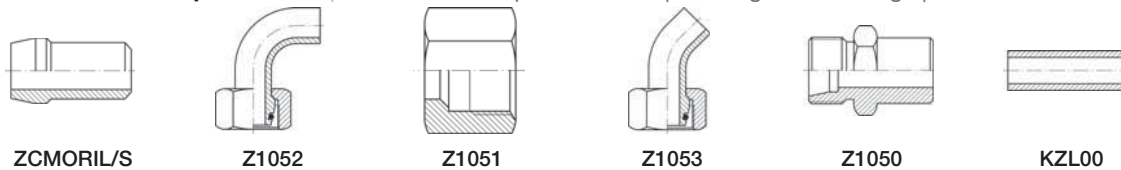

### Racores para soldar >2" | Raccords à souder >2" | Welding fittings >2" | Raccordi a saldare > 2"

161

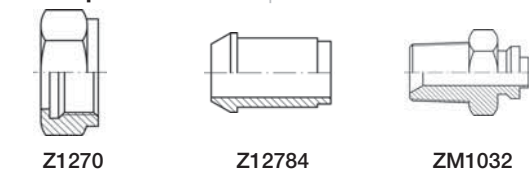

### Racores para soldar varios BSP | Autres raccords à souder BSP | Other welding fittings BSP | Raccordi a saldare vari BSP

162

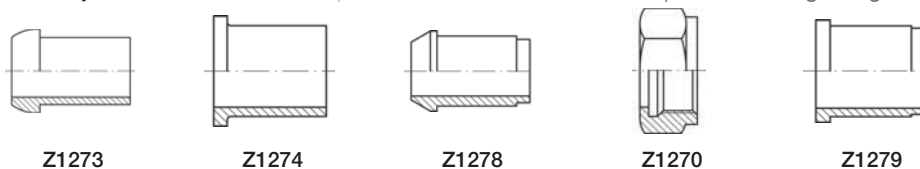

### Racores para soldar varios JIC | Autres raccords à souder JIC | Other welding fittings JIC | Raccordi a saldare vari JIC

163

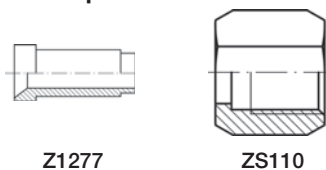

► **Bridas fijas para soldar** | Brides DIN à souder fixes | Fixed Forged flanges | Flange a saldare 164



ZBPN162633    ZBANSAWN150    ZBPN402635    ZBANSAWN300

► **Conjunto brida DIN 2642** | Ensemble brides tournantes DIN 2642 | DIN 2642 swivel flanges set | Flangia girevole DIN 2642 165

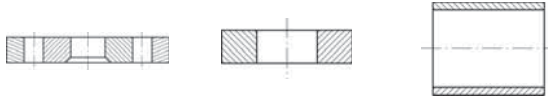

ZBPN102642    ZABARO2642    ZBTUBO

► **Conjunto brida DIN 2656** | Ensemble brides tournantes DIN 2656 | DIN 2656 swivel flanges set | Flangia girevole DIN 2656 166

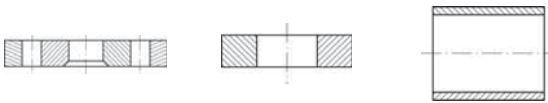

ZBPN402656    ZABARO2656    ZBTUBO

► **Conjunto bridas ANSI-ASA** | Ensemble brides ANSI-ASA | ANSI-ASA swivel flanges set | Flangia girevole ANSI-ASA 167

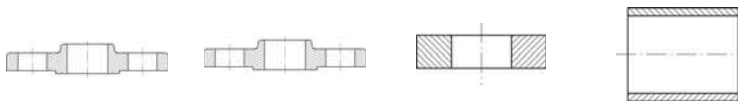

ZBANSASO150    ZBANSASO300    ZABAROANSA    ZBTUBO

► **Racores Microfundido para soldar** | Raccords à souder micro-moulés | Welding fittings microcast | Raccordi per saldatura microfuso 168

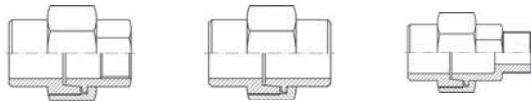

ZFIG340...HS    ZFIG340...S    ZFIG341...MS



## Racores para soldar

Raccords à souder  
Welding fittings  
Raccordi a saldare

### Casquillo soldable

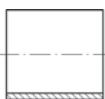

Jupe à souder  
Welding ferrule  
Boccola a saldare

DN	Ø in	REFERENCIA PART N°	€
1/4"	14	810700400	
1/4"	12	810700401	
3/8"	19	810700600	
3/8"	17	810700601	
1/2"	22	810700800	
1/2"	19	810700801	
5/8"	25	810701000	
3/4"	30	810701200	
3/4"	32	810701201	
1"	35	810701500	
1"	38	810701600	
1"1/4	47,8	810702000	
1"1/4	44,3	810702001	
1"1/2	56,1	810702400	
2"	70	810703200*	
2"	66	810703201	
2"1/2	84,8	810704000	
2"1/2	95,6	810704001	
3"	108,2	810704800*	
3"	100	810704801	
4"	125	810706400	

\*Hasta fin de existencias./\*/Jusqu'à fin du stock./\*/Until end of stock./\*/Fino ad esaurimento scorta.

### Macho soldable BSP cono 60° con guía

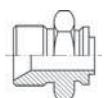

Mâle gaz BSP 60° à souder avec guide  
Welding BSP 60° Male with guide  
Maschio a saldare BSP 60° con guida

DN	ROSCA THREAD	REFERENCIA PART N°	€
1/4"	1/4" BSP	Z103504	
3/8"	3/8" BSP	Z103506	
1/2"	1/2" BSP	Z103508	
3/4"	3/4" BSP	Z103512	
1"	1" BSP	Z103516	
1"1/4	1"1/4 BSP	Z103520	
1"1/2	1"1/2 BSP	Z103524	
2"	2" BSP	Z103532	

### Macho BSP 60° soldable interior

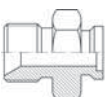

Mâle à souder int. BSP inox  
Welding interior BSP Male  
Maschio BSP 60° a saldare interno

DN	ROSCA THREAD	REFERENCIA PART N°	€
1/4"	1/4" BSP	Z1035104	
3/8"	3/8" BSP	Z1035106	
1/2"	1/2" BSP	Z1035108	
3/4"	3/4" BSP	Z1035112	
1"	1" BSP	Z1035116	
1"1/4	1"1/4 BSP	Z1035120	
1"1/2	1"1/2 BSP	Z1035124	
2"	2" BSP	Z1035132	

### Macho soldable BSP asiento plano con guía

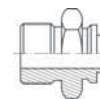

Mâle gaz BSP fond plat à souder avec guide  
Welding BSP Male flat seat with guide  
Maschio a saldare BSP faccia piana con guida

DN	ROSCA THREAD	REFERENCIA PART N°	€
1/4"	1/4" BSP	Z103304	
3/8"	3/8" BSP	Z103306	
1/2"	1/2" BSP	Z103308	
3/4"	3/4" BSP	Z103312	
1"	1" BSP	Z103316	
1"1/4	1"1/4 BSP	Z103320	
1"1/2	1"1/2 BSP	Z103324	
2"	2" BSP	Z103332	

### Macho soldable BSPT cono 60° con guía

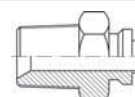

Mâle gaz conique à souder 60° avec guide  
Welding BSPT Male 60° with guide  
Maschio conico BSPT 60° con guida

DN	ROSCA THREAD	REFERENCIA PART N°	€
1/4"	1/4" BSPT	Z103204	
3/8"	3/8" BSPT	Z103206	
1/2"	1/2" BSPT	Z103208	
3/4"	3/4" BSPT	Z103212	
1"	1" BSPT	Z103216	
1"1/4	1"1/4 BSPT	Z103220	
1"1/2	1"1/2 BSPT	Z103224	
2"	2" BSPT	Z103232	

### Macho soldable NPT cono 60° con guía



Mâle NPT à souder 60° avec guide  
Welding NPT Male 60° with guide  
Maschio a saldare NPT 60° con guida

DN	ROSCA THREAD	REFERENCIA PART N°	€
1/4"	1/4" NPT	Z10340400	
3/8"	3/8" NPT	Z10340600	
1/2"	1/2" NPT	Z10340800	
3/4"	3/4" NPT	Z10341200	
1"	1" NPT	Z10341600	
1"1/4	1"1/4 NPT	Z10342000	
1"1/2	1"1/2 NPT	Z10342400	
2"	2" NPT	Z10343200	

## Racores para soldar

Raccords à souder  
Welding fittings  
Raccordi a saldare

### Empalme liso soldable macho BSP 60°

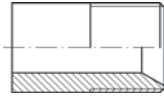

Embout mâle lisse à souder BSP cône 60°

Welding union male BSP 60°

Mezzo Niples tondo maschio a saldare BSP 60°

DN	ROSCA THREAD	REFERENCIA PART N°	€
1/8"	1/8" BSP	Z129002	
1/4"	1/4" BSP	Z129004	
3/8"	3/8" BSP	Z129006	
1/2"	1/2" BSP	Z129008	
3/4"	3/4" BSP	Z129012	
1"	1" BSP	Z129016	
1"1/4	1"1/4 BSP	Z129020	
1"1/2	1"1/2 BSP	Z129024	
2"	2" BSP	Z129032	

### Hembra giratoria prensada soldable BSP 60° con guía

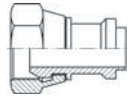

Femelle tournante BSP 60° à souder avec guide

Welding BSP 60° swept with guide

Femmina girevole a saldare BSP 60° con guida

DN	ROSCA THREAD	REFERENCIA PART N°	€
1/4"	1/4" BSP	Z128104	
3/8"	3/8" BSP	Z128106	
1/2"	1/2" BSP	Z128108	
3/4"	3/4" BSP	Z128112	
1"	1" BSP	Z128116	
1"1/4	1"1/4 BSP	Z128120	
1"1/2	1"1/2 BSP	Z128124	
2"	2" BSP	Z128132	

### Hembra giratoria prensada soldable BSP asiento plano con guía

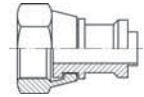

Femelle tournante BSP fond plat à souder avec guide

Welding BSP flat seat swept with guide

Femmina girevole a saldare BSP faccia piana con guida

DN	ROSCA THREAD	REFERENCIA PART N°	€
1/4"	1/4" BSP	Z128204	
3/8"	3/8" BSP	Z128206	
1/2"	1/2" BSP	Z128208	
3/4"	3/4" BSP	Z128212	
1"	1" BSP	Z128216	
1"1/4	1"1/4 BSP	Z128220	
1"1/2	1"1/2 BSP	Z128224	
2"	2" BSP	Z128232	

### Hembra giratoria 90° prensada soldable BSP 60°



Femelle tournante à souder 90° BSP cône 60°

Welding BSP 60° swept 90°

Femmina girevole 90° a saldare BSP 60°

DN	ROSCA THREAD	REFERENCIA PART N°	€
1/4"	1/4" BSP	Z103704	
3/8"	3/8" BSP	Z103706	
1/2"	1/2" BSP	Z103708	
3/4"	3/4" BSP	Z103712	
1"	1" BSP	Z103716	
1"1/4	1"1/4 BSP	Z103720	
1"1/2	1"1/2 BSP	Z103724	
2"	2" BSP	Z103732	

### Hembra giratoria 90° prensada soldable BSP asiento plano



Femelle tournante à souder 90° BSP fond plat

Welding BSP Female 90° flat seat

Femmina 90° girevole a saldare BSP faccia piana

DN	ROSCA THREAD	REFERENCIA PART N°	€
1/4"	1/4" BSP	Z103904	
3/8"	3/8" BSP	Z103906	
1/2"	1/2" BSP	Z103908	
3/4"	3/4" BSP	Z103912	
1"	1" BSP	Z103916	
1"1/4	1"1/4 BSP	Z103920	
1"1/2	1"1/2 BSP	Z103924	
2"	2" BSP	Z103932	



## Racores para soldar

Raccords à souder  
Welding fittings  
Raccordi a saldare

### Hembra giratoria 45° prensada soldable BSP 60°



Femelle tournante à souder 45° BSP cône 60°

Welding BSP 60° swept 45°

Femmina girevole 45° a saldare BSP 60°

DN	ROSCA THREAD	REFERENCIA PART N°	€
1/4"	1/4" BSP	Z103804	
3/8"	3/8" BSP	Z103806	
1/2"	1/2" BSP	Z103808	
3/4"	3/4" BSP	Z103812	
1"	1" BSP	Z103816	
1"1/4	1"1/4 BSP	Z103820	
1"1/2	1"1/2 BSP	Z103824	
2"	2" BSP	Z103832	

### Hembra giratoria 45° prensada soldable BSP asiento plano



Femelle tournante à souder 45° BSP fond plat

Welding BSP Female 45° flat seat

Femmina 45° girevole a saldare BSP faccia piana

DN	ROSCA THREAD	REFERENCIA PART N°	€
1/4"	1/4" BSP	Z104004	
3/8"	3/8" BSP	Z104006	
1/2"	1/2" BSP	Z104008	
3/4"	3/4" BSP	Z104012	
1"	1" BSP	Z104016	
1"1/4	1"1/4 BSP	Z104020	
1"1/2	1"1/2 BSP	Z104024	
2"	2" BSP	Z104032	

### Hembra giratoria prensada soldable JIC 37° con guía

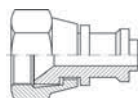

Femelle tournante JIC 37° à souder avec guide

Welding JIC swivel female 37° with guide

Femmina girevole a saldare JIC 37°

DN	ROSCA THREAD	REFERENCIA PART N°	€
1/4"	7/16" 20h UNF	Z12830704	
1/4"	1/2" 20h UNF	Z12830804	
3/8"	9/16" 18h UNF	Z12830906	
3/8"	3/4" 16h UNF	Z12831206	
1/2"	3/4" 16h UNF	Z12831208	
1/2"	7/8" 14h UNF	Z12831408	
3/4"	1"1/16 12h UN	Z12831712	
1"	1"5/16 12h UN	Z12832116	
1"1/4	1"5/8 12h UN	Z12832620	
1"1/2	1"7/8 12h UN	Z12833024	

### Hembra giratoria 90° prensada soldable JIC 37°



Femelle tournante à souder 90° JIC 37°

Welding 90° JIC Female 37°

Femmina 90° girevole a saldare JIC

DN	ROSCA THREAD	REFERENCIA PART N°	€
1/4"	7/16" 20h UNF	Z10410704	
1/4"	1/2" 20h UNF	Z10410804	
3/8"	9/16" 18h UNF	Z10410906	
1/2"	3/4" 16h UNF	Z10411208	
1/2"	7/8" 14h UNF	Z10411408	
3/4"	1"1/16 12h UN	Z10411712	
1"	1"5/16 12h UN	Z10412116	
1"1/4	1"5/8 12h UN	Z10412620	
1"1/2	1"7/8 12h UN	Z10413024	

### Macho soldable JIC 37° con guía

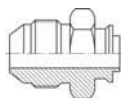

Mâle à souder JIC 37° avec guide

Welding fixed male JIC 37° with guide

Maschio JIC 37° a saldare

DN	ROSCA THREAD	REFERENCIA PART N°	€
1/4"	7/16" 20h UNF	Z10360704	
1/4"	1/2" 20h UNF	Z10360804	
3/8"	9/16" 18h UNF	Z10360906	
3/8"	3/4" 16h UNF	Z10361206	
1/2"	3/4" 16h UNF	Z10361208	
1/2"	7/8" 14h UNF	Z10361408	
5/8"	7/8" 14h UNF	Z10361410	
3/4"	1"1/16 12h UN	Z10361712	
1"	1"5/16 12h UN	Z10362116	
1"1/4	1"5/8 12h UN	Z10362620	
1"1/4	1"7/8 12h UN	Z10363020	

### Hembra giratoria 45° prensada soldable JIC 37°



Femelle tournante à souder 45° JIC 37°

Welding 45° JIC Female 37°

Femmina 45° girevole a saldare JIC

DN	ROSCA THREAD	REFERENCIA PART N°	€
1/4"	7/16" 20h UNF	Z10420704	
1/4"	1/2" 20h UNF	Z10420804	
3/8"	9/16" 18h UNF	Z10420906	
1/2"	3/4" 16h UNF	Z10421208	
1/2"	7/8" 14h UNF	Z10421408	
3/4"	1"1/16 12h UN	Z10421712	
1"	1"5/16 12h UN	Z10422116	
1"1/4	1"5/8 12h UN	Z10422620	
1"1/2	1"7/8 12h UN	Z10423024	

## Racores para soldar

Raccords à souder  
Welding fittings  
Raccordi a saldare

### Boquilla para soldar cono metal

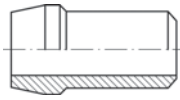

Raccord collet cône métallique à souder  
Welding nipple metal cone  
Ogiva a saldare senza o'ring

TUBO PIPE	SERIE	REFERENCIA PART N°	€
8	L	Z CMORIL 8	
10	L	Z CMORIL 10	
12	L	Z CMORIL 12	
15	L	Z CMORIL 15	
18	L	Z CMORIL 18	
22	L	Z CMORIL 22	
28	L	Z CMORIL 28	
35	L	Z CMORIL 35	
42	L	Z CMORIL 42	
16	S	Z CMORIS 16	
20	S	Z CMORIS 20	
25	S	Z CMORIS 25	
30	S	Z CMORIS 30	
38	S	Z CMORIS 38	

### Tuercas Métricas



Écrou DIN  
DIN nut  
Dado DIN

TUBO PIPE	ROSCA THREAD	REFERENCIA PART N°	€
6	M12X1.5	Z10510612	
6	M14X1.5	Z10510614	
8	M14X1.5	Z10510814	
8	M16X1.5	Z10510816	
10	M16X1.5	Z10511016	
10	M18X1.5	Z10511018	
12	M18X1.5	Z10511218	
12	M20X1.5	Z10511220	
14	M22X1.5	Z10511422	
15	M22X1.5	Z10511522	
16	M24X1.5	Z10511624	
18	M26X1.5	Z10511826	
20	M30X2	Z10512030	
22	M30X2	Z10512230	
25	M36X2	Z10512536	
28	M36X2	Z10512836	
30	M42X2	Z10513042	
35	M45X2	Z10513545	
38	M52X2	Z10513852	
42	M52X2	Z10514252	

### Hembra giratoria 90° soldable métrica



Femelle tournante 90° métrique à souder  
Weldable metrical swivel female 90°  
Femmina girevole 90° metrica a saldare

TUBO PIPE	ROSCA THREAD	REFERENCIA PART N°	€
6	M12X1.5	Z10521206	
8	M14X1.5	Z10521408	
10	M16X1.5	Z10521610	
12	M18X1.5	Z10521812	
15	M22X1.5	Z10522215	
18	M26X1.5	Z10522618	
22	M30X2	Z10523022	
28	M36X2	Z10523628	
35	M45X2	Z10524535	
42	M52X2	Z10525242	
6	M14X1.5	Z10521406	
8	M16X1.5	Z10521608	
10	M18X1.5	Z10521810	
12	M20X1.5	Z10522012	
14	M22X1.5	Z10522214	
16	M24X1.5	Z10522416	
20	M30X2	Z10523020	
25	M36X2	Z10523625	
30	M42X2	Z10524230	
38	M52X2	Z10525238	

### Hembra giratoria 45° soldable métrica



Femelle tournante 45° métrique à souder  
Weldable metrical swivel female 45°  
Femmina girevole 45° metrica a saldare

TUBO PIPE	ROSCA THREAD	REFERENCIA PART N°	€
6	M12X1.5	Z10531206	
8	M14X1.5	Z10531408	
10	M16X1.5	Z10531610	
12	M18X1.5	Z10531812	
15	M22X1.5	Z10532215	
18	M26X1.5	Z10532618	
22	M30X2	Z10533022	
28	M36X2	Z10533628	
35	M45X2	Z10534535	
42	M52X2	Z10535242	
6	M14X1.5	Z10531406	
8	M16X1.5	Z10531608	
10	M18X1.5	Z10531810	
12	M20X1.5	Z10532012	
14	M22X1.5	Z10532214	
16	M24X1.5	Z10532416	
20	M30X2	Z10533020	
25	M36X2	Z10533625	
38	M52X2	Z10535238	

## Racores para soldar

Raccords à souder  
Welding fittings  
Raccordi a saldare

### Macho soldable Métrico

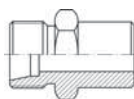

Mâle à souder métrique  
Welding DIN Male  
Maschio saldare DIN

TUBO PIPE	SERIE	REFERENCIA PART N°	€
6	L	Z1050L06	
8	L	Z1050L08	
10	L	Z1050L10	
12	L	Z1050L12	
15	L	Z1050L15	
18	L	Z1050L18	
22	L	Z1050L22	
28	L	Z1050L28	
35	L	Z1050L35	
42	L	Z1050L42	
6	S	Z1050S06	
8	S	Z1050S08	
10	S	Z1050S10	
12	S	Z1050S12	
14	S	Z1050S14	
16	S	Z1050S16	
20	S	Z1050S20	
25	S	Z1050S25	
30	S	Z1050S30	
38	S	Z1050S38	

### Espiga lisa métrica recta

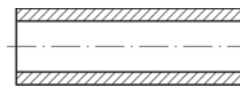

Embout lisse métrique à souder  
Welding metric standpipe  
Estremità tubolare metrica diritta

Ø ext Ø outer	REFERENCIA PART N°	€
6	KZL0006	
8	KZL0008	
10	KZL0010	
12	KZL0012	
14	KZL0014	
15	KZL0015	
16	KZL0016	
18	KZL0018	
20	KZL0020	
22	KZL0022	

### Tuercas BSP Microfundido AISI-316



Écrous BSP en acier moulé AISI-316  
Micro-casting BSP nuts AISI-316  
Dadi BSP microfusi AISI-316

ROSCA THREAD	REFERENCIA PART N°	€
2"1/2 BSP	Z127040	
3" BSP	Z127048	
4" BSP	Z127064	

### Macho BSPT soldar microfundido AISI-316

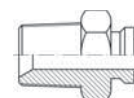

Mâle BSPT à souder en acier moulé AISI-316  
Micro-casting BSPT welding male AISI-316  
Maschio BSPT a saldare microfuso AISI-316

DN	ROSCA THREAD	REFERENCIA PART N°	€
2"1/2	2"1/2 BSPT	ZM103240	
3"	3" BSPT	ZM103248	
4"	4" BSPT	ZM103264	

### Cono ajuste BSP 60° con guía



Collet à souder BSP cone 60° avec guide  
Welding nipple with 60° cone for BSP nut with guide  
Ogiva a saldare cono 60° con guida per dado BSP

DN	ROSCA THREAD	REFERENCIA PART N°	€
2"1/2	2"1/2 BSP	Z127840	
3"	3" BSP	Z127848	
4"	4" BSP	Z127864	

## Racores para soldar

Raccords à souder  
Welding fittings  
Raccordi a saldare

### Cono ajuste BSP 60°

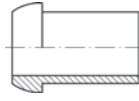

Collet à souder BSP cone 60°  
Welding nipple BSP 60°  
Ogiva a saldare BSP

ROSCA THREAD	Ø ext Ø outer	REFERENCIA PART N°	€
1/4" BSP	9	Z127304	
3/8" BSP	13	Z127306	
1/2" BSP	16	Z127308	
3/4" BSP	21	Z127312	
1" BSP	27	Z127316	
1"1/4 BSP	33	Z127320	
1"1/2 BSP	41.5	Z127324	
2" BSP	52.5	Z127332	

### Cono ajuste BSP asiento plano

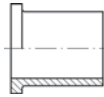

Collet à souder BSP fond plat  
Welding nipple BSP flat seat  
Ogiva a saldare sede piana

ROSCA THREAD	Ø ext Ø outer	REFERENCIA PART N°	€
1/4 BSP	9	Z127404	
3/8 BSP	13	Z127406	
1/2 BSP	16	Z127408	
3/4 BSP	21	Z127412	
1" BSP	27	Z127416	

\*Hasta fin de existencias.// \*Jusqu'à fin du stock.// \*Until end of stock.// \*Fino ad esaurimento scorta.

### Cono ajuste BSP 60° con guía

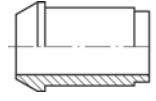

Collet à souder BSP cone 60° avec guide  
Welding nipple with 60° cone for BSP nut with guide  
Ogiva a saldare cono 60° con guida per dado BSP

DN	ROSCA THREAD	REFERENCIA PART N°	€
1/4"	1/4" BSP	Z127804	
3/8"	3/8" BSP	Z127806	
1/2"	1/2" BSP	Z127808	
3/4"	3/4" BSP	Z127812	
1"	1" BSP	Z127816	
1"1/4	1"1/4 BSP	Z127820	
1"1/2	1"1/2 BSP	Z127824	
2"	2" BSP	Z127832	

\*Hasta fin de existencias. Ver H.G. SOLDAR BSP (Z1281...)// \*Jusqu'à la fin du stock. Voir FEM.TOURN.À SOUDER BSP (Z1281...)// \*Until end of stock. See WELDABLE SWIVEL FEM.BSP (Z1281...)// \*Fino ad esaurimento scorta. Vedere FEM. GIREV. BSP SALDARE (Z1281...)

### Tuerca cono ajuste BSP



Écrou gaz pour collet à souder  
BSP Nut for welding nipple 60° cone  
Dado BSP per ogiva a saldare cono 60°

ROSCA THREAD	REFERENCIA PART N°	€
1/4" BSP	Z127004	
3/8" BSP	Z127006	
1/2" BSP	Z127008	
3/4" BSP	Z127012	
1" BSP	Z127016	
1"1/4 BSP	Z127020	
1"1/2 BSP	Z127024	
2" BSP	Z127032	

### Cono ajuste BSP asiento plano con guía

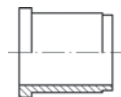

Collet à souder BSP fond plat avec guide  
Welding nipple for BSP nut with guide flat seat  
Ogiva a saldare BSP faccia piana con guida

DN	ROSCA THREAD	REFERENCIA PART N°	€
1"1/4	1"1/4 BSP	Z127920	
1"1/2	1"1/2 BSP	Z127924	
2"	2" BSP	Z127932	

\*Hasta fin de existencias.// \*Jusqu'à fin du stock.// \*Until end of stock.// \*Fino ad esaurimento scorta.

## Racores para soldar

Raccords à souder  
Welding fittings  
Raccordi a saldare

### Cono ajuste JIC 37° con guía

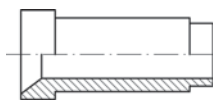

Collet à souder femelle JIC cone 37° avec guide  
Welding nipple for JIC 37° with guide  
Ogiva a saldare cono JIC 37° con guida

DN	ROSCA THREAD	REFERENCIA PART N°	€
1/4"	7/16" 20h UNF	Z12770704	
1/4"	1/2" 20h UNF	Z12770804	
3/8"	9/16" 18h UNF	Z12770906	
3/8"	3/4" 16h UNF	Z12771206	
1/2"	3/4" 16h UNF	Z12771208	
1/2"	7/8" 14h UNF	Z12771408	
5/8"	7/8" 14h UNF	Z12771410	
3/4"	1"1/16 12h UN	Z12771712	
1"	1"5/16 12h UN	Z12772116	
1"1/4	1"5/8 12h UN	Z12772620	
1"1/4	1"7/8 12h UN	Z12773020	
1"1/2	1"7/8 12h UN	Z12773024	

\*Hasta fin de existencias// \*Jusqu'à fin du stock// \*Until end of stock// \*Fino ad esaurimento scorte

### Tuercas JIC



Écrou JIC  
JIC nut  
Dado JIC

TUBO PIPE	ROSCA THREAD	REFERENCIA PART N°	€
6	1/4	7/16" 20h UNF	ZS11006
8	5/16	1/2" 20h UNF	ZS11008
10	3/8	9/16" 18h UNF	ZS11010
12	1/2	3/4" 16h UNF	ZS11012
14-15-16	5/8	7/8" 14h UNF	ZS11016
18-20	-	1"1/16 12h UN	ZS11020
-	3/4	1"1/16 12h UNF	ZS11020W
25	1	1"5/16 12h UN	ZS11025
30-32	1 1/4	1"5/8 12h UN	ZS11032
38	1 1/2	1"7/8 12h UN	ZS11038

Ver precios en p.117 (R. JIC)//Prix à la page 117 (R. JIC)//See prices in p.117 (JIC Fittings)//Vedere prezzi p.117 (R. JIC)

## Racores para soldar

Raccords à souder  
Welding fittings  
Raccordi a saldare

Crimp fittings for hoses

Pipe fittings DIN 2353

Flare fittings JIC  
SAE flanges

Adaptors

Welding fittings

Industrial fittings

Several items

### Brida fija soldable PN10/16 DIN 2633

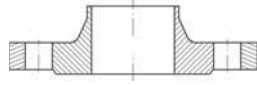

Bride fixe à souder DIN 2633 PN10/16  
Welding forged flange DIN 2633 PN 10/16  
Flangia forgiata a saldare DIN 2633 PN 10/16

DN	REFERENCIA PART N°	€
15-1/2"	ZBPN16263308	
20-3/4"	ZBPN16263312	
25-1"	ZBPN16263316	
32-1"1/4	ZBPN16263320	
40-1"1/2	ZBPN16263324	
50-2"	ZBPN16263332	
65-2"1/2	ZBPN16263340	
80-3"	ZBPN16263348	
100-4"	ZBPN16263364	

### Brida fija soldable PN40 DIN 2635

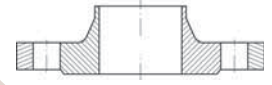

Bride fixe à souder DIN 2635 PN 40  
Welding forged flange DIN 2635 PN 40  
Flangia forgiata a saldare DIN 2635 PN 40

DN	REFERENCIA PART N°	€
15-1/2"	ZBPN40263508	
20-3/4"	ZBPN40263512	
25-1"	ZBPN40263516	
32-1"1/4	ZBPN40263520	
40-1"1/2	ZBPN40263524	
50-2"	ZBPN40263532	
65-2"1/2	ZBPN40263540	
80-3"	ZBPN40263548	
100-4"	ZBPN40263564	

### Brida fija ANSI-ASA 150 LBS

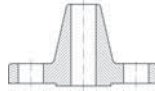

Bride ANSI-ASA Welding Neck 150 LBS  
Flange ANSI-ASA Welding Neck 150 LBS  
Flangia ANSI-ASA a saldare 150 LBS

DN	REFERENCIA PART N°	€
15-1/2"	ZBANSAWN15008	
20-3/4"	ZBANSAWN15012	
25-1"	ZBANSAWN15016	
32-1"1/4	ZBANSAWN15020	
40-1"1/2	ZBANSAWN15024	
50-2"	ZBANSAWN15032	
65-2"1/2	ZBANSAWN15040	
80-3"	ZBANSAWN15048	
100-4"	ZBANSAWN15064	

### Brida fija ANSI-ASA 300 LBS

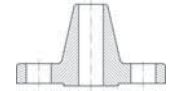

Bride ANSI-ASA Welding Neck 300 LBS  
FLANGE ANSI-ASA Welding Neck 300 LBS  
Flangia ANSI-ASA a saldare 300 LBS

DN	REFERENCIA PART N°	€
15-1/2"	ZBANSAWN30008	
20-3/4"	ZBANSAWN30012	
25-1"	ZBANSAWN30016	
32-1"1/4	ZBANSAWN30020	
40-1"1/2	ZBANSAWN30024	
50-2"	ZBANSAWN30032	
65-2"1/2	ZBANSAWN30040	
80-3"	ZBANSAWN30048	
100-4"	ZBANSAWN30064	

## Racores para soldar

Raccords à souder  
Welding fittings  
Raccordi a saldare

### Brida plana PN10 DIN 2642

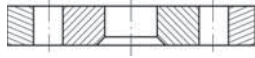

Bride tournante à souder DIN 2642 PN 10

Welding forged flange DIN 2642 PN 10

Flangia girevole a saldare DIN 2642 PN 10

DN	REFERENCIA PART N°	€
15-1/2"	ZBPN10264208	
20-3/4"	ZBPN10264212	
25-1"	ZBPN10264216	
32-1"1/4	ZBPN10264220	
40-1"1/2	ZBPN10264224	
50-2"	ZBPN10264232	
65-2"1/2	ZBPN10264240	
80-3"	ZBPN10264248	
100-4"	ZBPN10264264	

### Tubo para soldar bridas ANSI-DIN

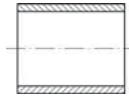

Tube à souder brides ANSI-DIN

Tube for welding flanges ANSI-DIN

Tubo per flangia a saldare ANSI-DIN

DN	REFERENCIA PART N°	€
3/8"	ZBTUBO06	
1/2"	ZBTUBO08	
3/4"	ZBTUBO12	
1"	ZBTUBO16	
1"1/4	ZBTUBO20	
1"1/2	ZBTUBO24	
2"	ZBTUBO32	
2"1/2	ZBTUBO40	
3"	ZBTUBO48	
4"	ZBTUBO64	

### Aro para brida DIN 2642

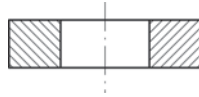

Collet épais pour bride DIN 2642

Ring for flange DIN 2642

Anello per flangia DIN 2642

DN	REFERENCIA PART N°	€
3/8"	ZABARO264206	
1/2"	ZABARO264208	
3/4"	ZABARO264212	
1"	ZABARO264216	
1"1/4	ZABARO264220	
1"1/2	ZABARO264224	
2"	ZABARO264232	
2"1/2	ZABARO264240	
3"	ZABARO264248	
4"	ZABARO264264	

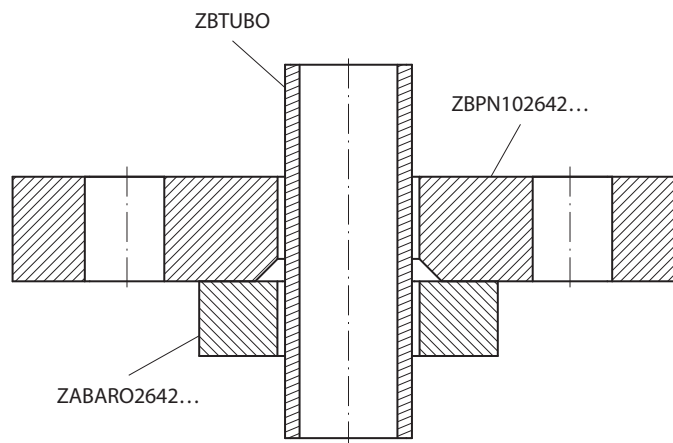

## Racores para soldar

Raccords à souder  
Welding fittings  
Raccordi a saldare

Crimp fittings for hoses

Pipe fittings DIN 2353

Flare fittings JIC  
SAE flanges

Adaptors

Welding fittings

Industrial fittings

Several items

### Brida plana PN40 DIN 2656

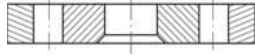

Bride tournante à souder DIN 2656 PN 40

Welding forged flange DIN 2656 PN 40

Flangia girevole a saldare DIN 2656 PN 40

DN	REFERENCIA PART N°	€
15-1/2"	ZBPN40265608	
20-3/4"	ZBPN40265612	
25-1"	ZBPN40265616	
32-1"1/4	ZBPN40265620	
40-1"1/2	ZBPN40265624	
50-2"	ZBPN40265632	
65-2"1/2	ZBPN40265640	
80-3"	ZBPN40265648	
100-4"	ZBPN40265664	

### Aro para brida DIN 2656

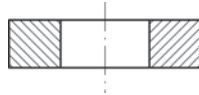

Collet épais pour bride DIN 2656

Ring for flange DIN 2656

Anello per flangia DIN 2656

DN	REFERENCIA PART N°	€
3/8"	ZABARO265606	
1/2"	ZABARO265608	
3/4"	ZABARO265612	
1"	ZABARO265616	
1"1/4	ZABARO265620	
1"1/2	ZABARO265624	
2"	ZABARO265632	
2"1/2	ZABARO265640	
3"	ZABARO265648	

### Tubo para soldar bridas ANSI-DIN

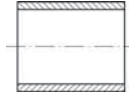

Tube à souder brides ANSI-DIN

Tube for welding flanges ANSI-DIN

Tubo per flangia a saldare ANSI-DIN

DN	REFERENCIA PART N°	€
3/8"	ZBTUBO06	
1/2"	ZBTUBO08	
3/4"	ZBTUBO12	
1"	ZBTUBO16	
1"1/4	ZBTUBO20	
1"1/2	ZBTUBO24	
2"	ZBTUBO32	
2"1/2	ZBTUBO40	
3"	ZBTUBO48	
4"	ZBTUBO64	

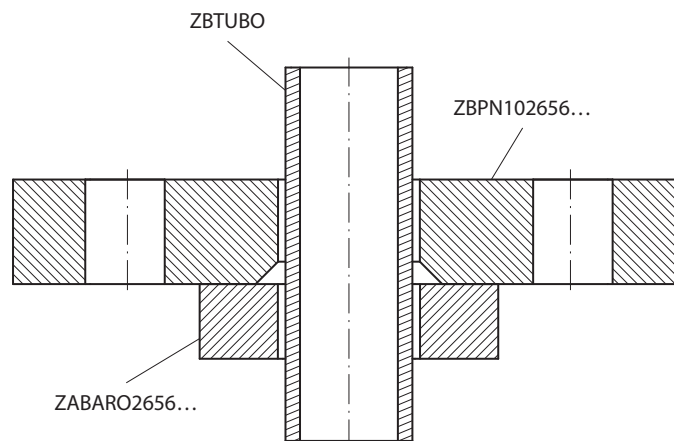



## Racores para soldar

Raccords à souder  
Welding fittings  
Raccordi a saldare

### Brida plana ANSI-ASA 150 LBS



Bride tournante ANSI-ASA 150 LBS  
Swivel flange ANSI-ASA 150 LBS  
Flangia girevole ANSI-ASA 150 LBS

DN	REFERENCIA PART N°	€
15-1/2"	ZBANSASO15008	
20-3/4"	ZBANSASO15012	
25-1"	ZBANSASO15016	
32-1"1/4	ZBANSASO15020	
40-1"1/2	ZBANSASO15024	
50-2"	ZBANSASO15032	
65-2"1/2	ZBANSASO15040	
80-3"	ZBANSASO15048	
100-4"	ZBANSASO15064	

### Brida plana ANSI-ASA 300 LBS



Bride tournante ANSI-ASA 300 LBS  
Swivel flange ANSI-ASA 300 LBS  
Flangia girevole ANSI-ASA 300 LBS

DN	REFERENCIA PART N°	€
15-1/2"	ZBANSASO30008	
20-3/4"	ZBANSASO30012	
25-1"	ZBANSASO30016	
32-1"1/4	ZBANSASO30020	
40-1"1/2	ZBANSASO30024	
50-2"	ZBANSASO30032	
65-2"1/2	ZBANSASO30040	
80-3"	ZBANSASO30048	
100-4"	ZBANSASO30064	

### Aro para brida ANSI-ASA

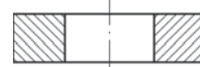

Collet épais pour bride ANSI-ASA  
Ring for flange ANSI-ASA  
Anello per flangia ANSI-ASA

DN	REFERENCIA PART N°	€
1/2"	ZABAROANSA08	
3/4"	ZABAROANSA12	
1"	ZABAROANSA16	
1"1/4	ZABAROANSA20	
1"1/2	ZABAROANSA24	
2"	ZABAROANSA32	
2"1/2	ZABAROANSA40	
3"	ZABAROANSA48	
4"	ZABAROANSA64	

### Tubo para soldar bridas ANSI-DIN

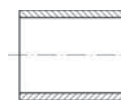

Tube à souder brides ANSI-DIN  
Tube for welding flanges ANSI-DIN  
Tubo per flangia a saldare ANSI-DIN

DN	REFERENCIA PART N°	€
3/8"	ZBTUBO06	
1/2"	ZBTUBO08	
3/4"	ZBTUBO12	
1"	ZBTUBO16	
1"1/4	ZBTUBO20	
1"1/2	ZBTUBO24	
2"	ZBTUBO32	
2"1/2	ZBTUBO40	
3"	ZBTUBO48	
4"	ZBTUBO64	

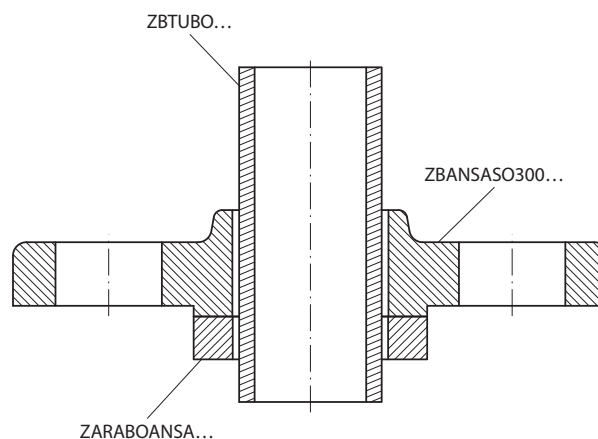
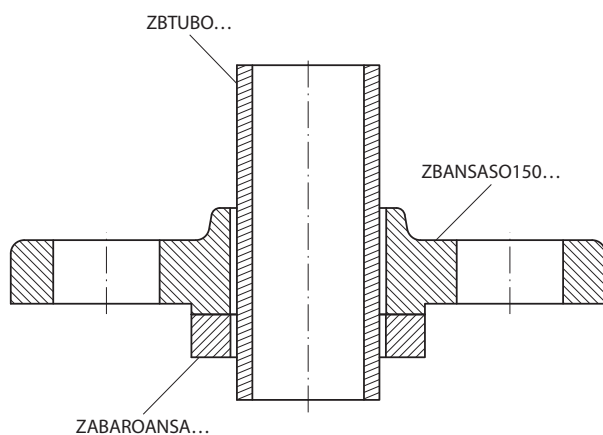

## Racores para soldar

Raccords à souder  
Welding fittings  
Raccordi a saldare

Crimp fittings for hoses

Pipe fittings DIN 2353

Flare fittings JIC  
SAE flanges

Adaptors

Welding fittings

Industrial fittings

Several items

### Unión 3 piezas hembra-soldar FIG.340HS microfundido

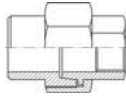

Union 3 pcs fem. à souder fig.340hs acier moulé  
Union 3 fem. welding pieces fig.340hs micro-casting  
Unione a 3 pezzi f.saldare fig.340hs microfusione

ROSCA THREAD	REFERENCIA PART N°	€
1/4"	ZFIG34004HS	
3/8"	ZFIG34006HS	
1/2"	ZFIG34008HS	
3/4"	ZFIG34012HS	
1"	ZFIG34016HS	
1" 1/4	ZFIG34020HS	
1" 1/2	ZFIG34024HS	
2"	ZFIG34032HS	

### Unión 3 piezas macho-soldar FIG.341MS microfundido

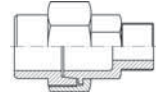

Union 3 pcs mâle à souder fig.341ms acier moulé  
Union 3 welding male pieces fig.341ms micro-casting  
Unione a 3 pezzi m.saldare fig.341ms microfusione

ROSCA THREAD	REFERENCIA PART N°	€
1/4"	ZFIG34104MS	
3/8"	ZFIG34106MS	
1/2"	ZFIG34108MS	
3/4"	ZFIG34112MS	
1"	ZFIG34116MS	
1" 1/4	ZFIG34120MS	
1" 1/2	ZFIG34124MS	
2"	ZFIG34132MS	

### Unión 3 piezas soldar FIG.340S microfundido

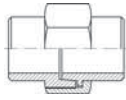

Union 3 pièces à souder fig. 340s acier moulé  
Union 3 welding pieces fig. 340s micro-casting  
Unione a 3 pezzi a saldare fig.340s microfusione

DN	REFERENCIA PART N°	€
1/4	ZFIG34004S	
3/8	ZFIG34006S	
1/2	ZFIG34008S	
3/4	ZFIG34012S	
1	ZFIG34016S	
1 1/4	ZFIG34020S	
1 1/2	ZFIG34024S	
2	ZFIG34032S	



Racores industriales

Raccords industriels

Industrial fittings

Raccordi industriali

▶	Industria alimentaria	170
	Raccords alimentaires   Food industry   Raccordi alimentari	
▶	Camlock AISI 316 - DIN 2828	171
	Raccords Camlock AISI 316 - DIN 2828   Camlock AISI 316 - DIN 2828   Camlock AISI 316 - DIN 2828	
▶	Racores baja presión 150 LBS	172
	Raccords basse pression 150 LBS   Screwed fittings low pressure 150 LBS   Raccordi bassa pressione 150 LBS	

▶ **Casquillos para presnar** | Jupes à sertir | Crimp ferrules | Boccole a pressare

173

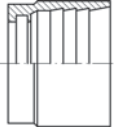

81042

▶ **Racores SMS** | Raccords SMS | SMS Unions | Raccordi SMS

174

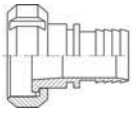

ZRA200

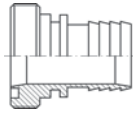

ZRA212



ZSMS H



ZSMS S



ZSMS M



JSMSS



JS MSP

▶ **Racores Tri-Clamp** | Raccords Tri-Clamp | Clamp Unions | Raccordi Tri-Clamp

175

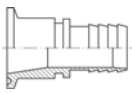

ZTC

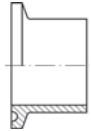

ZC



JCLAMPS



JCLAMPP

▶ **Racores DIN 11851** | Raccords DIN 11851 | DIN 11851 Unions | Raccordi DIN 11851

176

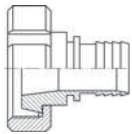

ZRA100

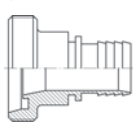

ZRA112



ZDIN H



ZDIN S



ZDIN M



JDINS



JDINP

▶ **Racores Macon** | Raccords Macon | Macon Unions | Raccordi Macon

177

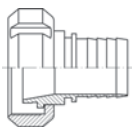

ZRA300

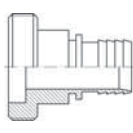

ZRA312



ZMAC H

▶ **Racores alimentarios para manguera PTFE corrugado Serie STD** | Raccords alimentaires pour tuyau PTFE convoluté Série STD | Food fittings for convoluted PTFE hose STD Series | Raccordi alimentari per tubo PTFE corrugato Serie STD

178

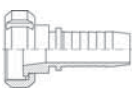

ZRA250

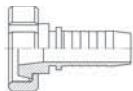

ZRA150

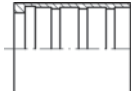

81041

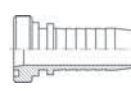

ZRA252

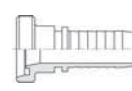

ZRA152

▶ **Racores alimentarios para manguera PTFE corrugado** | Raccords alimentaires pour tuyau PTFE convoluté | Food fittings for convoluted PTFE hose | Raccordi alimentari per tubo PTFE corrugato

179

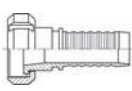

ZRA500

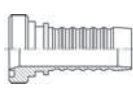

ZRA512

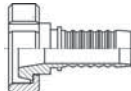

ZRA400

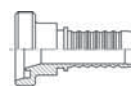

ZRA412

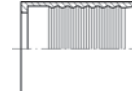

81050

# Camlock AISI 316 - DIN 2828

Raccords Camlock AISI 316 - DIN 2828 | Camlock AISI 316 - DIN 2828 | Camlock AISI 316 - DIN 2828

## Racores Camlock AISI 316 | Raccords Camlock AISI 316 | Camlock Unions AISI 316 | Raccordi Camlock AISI 316

180

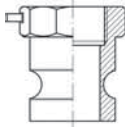

ZA

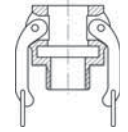

ZB

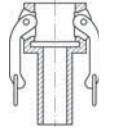

ZC

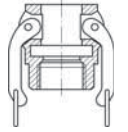

ZD

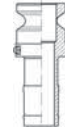

ZE0

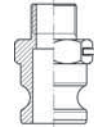

ZF

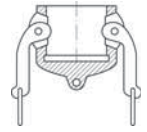

ZDC

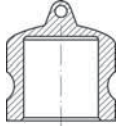

ZDP



JCAMNBR



JCAMS

# Racores baja presión 150 LBS

Raccords basse pression 150 LBS | Screwed fittings low pressure 150 LBS | Raccordi bassa pressione 150 LBS

Crimp fittings for hoses

Pipe fittings DIN 2353

Flare fittings JIC  
SAE flanges

Adaptors

Welding fittings

Industrial fittings

Several items

## Racores baja presión 150 LBS | Adapteurs basse pression 150 LBS | Screwed fittings low pressure 150 LBS | Raccordi bassa pressione

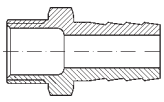

ZFIG399

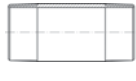

ZFIG150

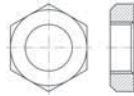

ZFIG312

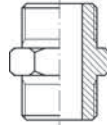

ZFIG280

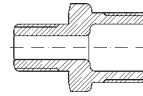

ZFIG245

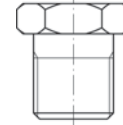

ZFIG290



ZFIG300

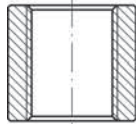

ZFIG270

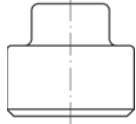

ZFIG291

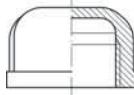

ZFIG301

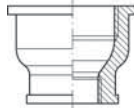

ZFIG240

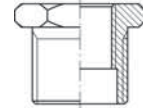

ZFIG241

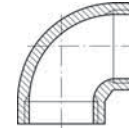

ZFIG090



ZFIG120

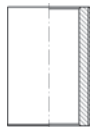

ZFIG531

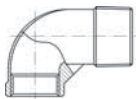

ZFIG092

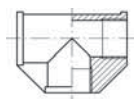

ZFIG130

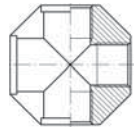

ZFIG180

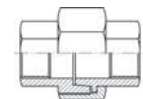

ZFIG340

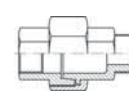

ZFIG341

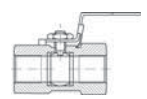

BP2V

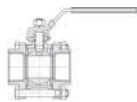

BP2V3P

## Soldables baja presión 150 LBS | Raccords à souder basse pression 150 LBS | Welding fittings low pressure 150 LBS | Raccordi bassa pressione per saldare 150 LBS

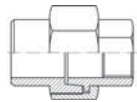

ZFIG340...HS

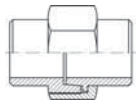

ZFIG340...S

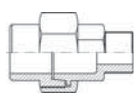

ZFIG341...MS

Casquillos para mangueras alimentarias



Jupes à sertir tuyaux alimentaires

Food hoses ferrules

Boccola a pressare per tubi alimentari

DN	Ø ext Ø outer	REFERENCIA PART N°	€
13-1/2"	23	810421324	
19-3/4"	32	810421933	
25-1"	39	810422540	
32-1"1/4	48	810423248	
38-1"1/2	52	810423852	
38-1"1/2	56	810423857	
40-1"1/2	54	810424055	
40-1"1/2	60	810424061	
50-2"	63	810425064	
50-2"	68	810425069	
50-2"	73	810425073	
65-2"1/2	79	810426580	
65-2"1/2	93	810426593	
70-3"	89	810427090	
75-3"	94	810427595	
75-3"	106	8104275107	
100-4"	122	81042100123	
100-4"	134	81042100135	



Crimp fittings for hoses

Pipe fittings DIN 2353

Flare fittings JIC  
SAE flanges

Adaptors

Welding fittings

Industrial fittings

Several items

# Industria alimentaria

Raccords alimentaires  
Food industry  
Raccordi alimentari

Crimp fittings for hoses

Pipe fittings DIN 2353

Flare fittings JIC  
SAE flanges

Adaptors

Welding fittings

Industrial fittings

Several items

## Hembras giratorias SMS

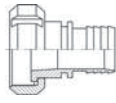

Raccord femelle tournante SMS  
Swivel female SMS  
Femmina girevole SMS

DN	ROSCA THREAD	REFERENCIA PART N°	€
25	40x1/6"	ZRA2004025	
32	48x1/6"	ZRA2004832	
38	60x1/6"	ZRA2006038	
40	60x1/6"	ZRA2006040	
50	70x1/6"	ZRA2007050	
65	85x1/6"	ZRA2008565	
70	98x1/6"	ZRA2009870	
75	98x1/6"	ZRA2009875	
80	98x1/6"	ZRA2009880	
100	125x1/4"	ZRA200125100	
100	132x1/4"	ZRA200132100	

## Machos fijos SMS

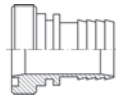

Raccord mâle SMS  
Fixed male SMS  
Maschio fisso SMS

DN	ROSCA THREAD	REFERENCIA PART N°	€
25	40x1/6"	ZRA2124025	
32	48x1/6"	ZRA2124832	
38	60x1/6"	ZRA2126038	
40	60x1/6"	ZRA2126040	
50	70x1/6"	ZRA2127050	
63	85x1/6"	ZRA2128563	
65	85x1/6"	ZRA2128565	
70	98x1/6"	ZRA2129870	
75	98x1/6"	ZRA2129875	
80	98x1/6"	ZRA2129880	
100	125x1/4"	ZRA212125100	
100	132x1/4"	ZRA212132100	

## Tuercas SMS



Écrou SMS  
Nuts SMS  
Dadi SMS

DN	ROSCA THREAD	D. D.	REFERENCIA PART N°	€
25	40x1/6"	6	ZSMS H 25	
32	48x1/6"	6	ZSMS H 32	
38	60x1/6"	6	ZSMS H 38	
51	70x1/6"	6	ZSMS H 51	
63	85x1/6"	6	ZSMS H 63	
76	98x1/6"	6	ZSMS H 76	
104	125x1/4"	6	ZSMS H 104	
104	132x1/4"	6	ZSMS H 105	

## Cono soldable SMS



Douilles à souder SMS  
Liner to weld SMS  
Sede a saldare per femmina SMS

DN	REFERENCIA PART N°	€
25	ZSMS S 25	
32	ZSMS S 32	
38	ZSMS S 38	
51	ZSMS S 51	
63	ZSMS S 63	
76	ZSMS S 76	
104	ZSMS S 104	

## Macho soldable SMS



Nez à souder SMS  
Weld male SMS  
Maschio a saldare SMS

DN	ROSCA THREAD	REFERENCIA PART N°	€
25	40x1/6"	ZSMS M 25	
32	48x1/6"	ZSMS M 32	
38	60x1/6"	ZSMS M 38	
51	70x1/6"	ZSMS M 51	
63	85x1/6"	ZSMS M 63	
76	98x1/6"	ZSMS M 76	
104	125x1/4"	ZSMS M 104	

## Junta SMS silicona



Joint silicone pour SMS  
Silicone joint for SMS  
Guarnizione in silicone per SMS

DN	REFERENCIA PART N°	€
25	JSMSS 25	
32	JSMSS 32	
38	JSMSS 38	
51	JSMSS 51	
63	JSMSS 63	
76	JSMSS 76	
104	JSMSS 104	

## Juntas SMS PTFE



Joint PTFE pour SMS  
PTFE Joint for SMS  
Guarnizione in PTFE per SMS

DN	REFERENCIA PART N°	€
25	JSMSP 25	
32	JSMSP 32	
38	JSMSP 38	
51	JSMSP 51	
63	JSMSP 63	
76	JSMSP 76	



**Tri-Clamp ISO 2852**

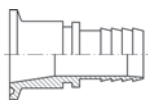

Raccord Tri-Clamp ISO 2852  
Tri-Clamp ISO 2852  
Tri-Clamp ISO 2852 per tubo flessibile

DN	Ø	REFERENCIA PART N°	€
12	25	ZTC2512	
12	34	ZTC3412	
19	34	ZTC3419	
19	50,5	ZTC5019	
25	50,5	ZTC5025	
32	50,5	ZTC5032	
38	50,5	ZTC5038	
40	50,5	ZTC5040	
38	64	ZTC6438	
40	64	ZTC6440	
50	64	ZTC6450	
50	77	ZTC7750	
65	91	ZTC9165	

**Tri-Clamp para soldar en tubo**



Raccord Tri-Clamp à souder pour tube  
Welding Tri-Clamp for pipe  
Tri-Clamp a saldare per tubo rigido

DN	Ø	REFERENCIA PART N°	€
12	25	ZC25-12	
12	34	ZC34-12	
18	34	ZC34-18	
18	50.5	ZC50-18	
25	50.5	ZC50-25	
33.7	50.5	ZC50-33.7	
38	50.5	ZC50-38	
38	64	ZC64-38	
51	64	ZC64-51	
65	91	ZC91-65	

**Junta para Clamp Silicona**



Joint pour clamp silicone  
Joint for silicone clamp  
JUNTA PARA CLAMP SILICONA

Ø	REFERENCIA PART N°	€
25	JCLAMPS 25	
34	JCLAMPS 34	
50	JCLAMPS 50	
64	JCLAMPS 64	
77	JCLAMPS 77	
91	JCLAMPS 91	

**Junta para Clamp PTFE**



Joint pour clamp PTFE  
Joint for PTFE clamp  
JUNTA PARA CLAMP PTFE

Ø	REFERENCIA PART N°	€
25	JCLAMPP 25	
34	JCLAMPP 34	
50	JCLAMPP 50	
64	JCLAMPP 64	
77	JCLAMPP 77	
91	JCLAMPP 91	

## Industria alimentaria

Raccords alimentaires  
Food industry  
Raccordi alimentari

Crimp fittings for hoses

Pipe fittings DIN 2353

Flare fittings JIC  
SAE flanges

Adaptors

Welding fittings

Industrial fittings

Several items

### Hembra giratoria DIN 11851



Raccord femelle tournante DIN 11851

Swivel female DIN 11851

Femmina girevole DIN 11851

DN	ROSCA THREAD	REFERENCIA PART N°	€
20	44x1/6"	ZRA1004420	
25	52x1/6"	ZRA1005225	
32	58x1/6"	ZRA1005832	
38	65x1/6"	ZRA1006538	
40	65x1/6"	ZRA1006540	
50	78x1/6"	ZRA1007850	
63	95x1/6"	ZRA1009563	
65	95x1/6"	ZRA1009565	
75	110x1/4"	ZRA10011075	
80	110x1/4"	ZRA10011080	
100	130x1/4"	ZRA100130100	

### Cono soldable DIN 11851

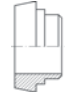

Douilles à souder DIN 11851

Liner to weld DIN 11851

Ogiva a saldare per dado DIN 11851

DN	REFERENCIA PART N°	€
16	ZDIN S 16	
20	ZDIN S 20	
25	ZDIN S 25	
32	ZDIN S 32	
40	ZDIN S 40	
50	ZDIN S 50	
65	ZDIN S 65	
75/80	ZDIN S 80	
100	ZDIN S 100	

### Macho fijo DIN 11851

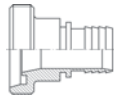

Raccord mâle DIN 11851

Fixed mâle DIN 11851

Maschio fisso DIN 11851

DN	ROSCA THREAD	REFERENCIA PART N°	€
25	52x1/6"	ZRA1125225	
32	58x1/6"	ZRA1125832	
38	65x1/6"	ZRA1126538	
40	65x1/6"	ZRA1126540	
50	78x1/6"	ZRA1127850	
63	95x1/6"	ZRA1129563	
65	95x1/6"	ZRA1129565	
75	110x1/4"	ZRA11211075	
80	110x1/4"	ZRA11211080	
100	130x1/4"	ZRA112130100	

### Macho soldable DIN 11851



Nez à souder DIN 11851

Weld male DIN 11851

Maschio a saldare DIN 11851

DN	ROSCA THREAD	REFERENCIA PART N°	€
16	34x1/8"	ZDIN M 16	
20	44x1/6"	ZDIN M 20	
25	52x1/6"	ZDIN M 25	
32	58x1/6"	ZDIN M 32	
40	65x1/6"	ZDIN M 40	
50	78x1/6"	ZDIN M 50	
65	95x1/6"	ZDIN M 65	
75/80	110x1/4"	ZDIN M 80	
100	130x1/4"	ZDIN M 100	

### Tuercas DIN 11851



Écrous DIN 11851

Nuts DIN 11851

Dado DIN 11851

DN	ROSCA THREAD	D. D.	REFERENCIA PART N°	€
16	34x1/8"	4	ZDIN H 16	
20	44x1/6"	4	ZDIN H 20	
25	52x1/6"	4	ZDIN H 25	
32	58x1/6"	4	ZDIN H 32	
40	65x1/6"	4	ZDIN H 40	
50	78x1/6"	4	ZDIN H 50	
65	95x1/6"	6	ZDIN H 65	
80	110x1/4"	6	ZDIN H 80	
100	130x1/4"	6	ZDIN H 100	

### Junta DIN 11851 silicona



Joint silicone pour DIN 11851

Silicone joint for DIN 11851

Guarnizione in silicone per DIN 11851

DN	REFERENCIA PART N°	€
20	JDINS 20	
25	JDINS 25	
32	JDINS 32	
40	JDINS 40	
50	JDINS 50	
65	JDINS 65	
80	JDINS 80	
100	JDINS 100	

**Junta DIN 11851 PTFE**



Joint PTFE pour DIN 11851  
PTFE Joint for DIN 11851  
Guarnizione in PTFE per DIN 11851

DN	REFERENCIA PART N°	€
20	<b>JDINP 20</b>	
25	<b>JDINP 25</b>	
32	<b>JDINP 32</b>	
40	<b>JDINP 40</b>	
50	<b>JDINP 50</b>	
65	<b>JDINP 65</b>	
80	<b>JDINP 80</b>	
100	<b>JDINP 100</b>	

**Hembra giratoria Macon**

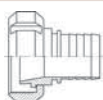

Raccord femelle tournante Macon  
Swivel female Macon  
Femmina girevole Macon

DN	ROSCA THREAD	REFERENCIA PART N°	€
38	M55x3	<b>ZRA3005538</b>	
40	M55x3	<b>ZRA3005540</b>	
50	M67x3	<b>ZRA3006750</b>	
65	M79x3,5	<b>ZRA3007965</b>	
65	M90x3,5	<b>ZRA3009065</b>	
70	M90x3,5	<b>ZRA3009070</b>	
80	M90x3,5	<b>ZRA3009080</b>	
80	M102x4	<b>ZRA30010280</b>	
100	M125x4	<b>ZRA300125100</b>	

**Macho fijo Macon**

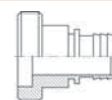

Raccord mâle fixe Macon  
Male fixe Macon  
Maschio fisso Macon

DN	ROSCA THREAD	REFERENCIA PART N°	€
38	M55x3	<b>ZRA3125538</b>	
40	M55x3	<b>ZRA3125540</b>	
50	M67x3	<b>ZRA3126750</b>	
65	M79x3,5	<b>ZRA3127965</b>	
65	M90x3,5	<b>ZRA3129065</b>	
70	M90x3,5	<b>ZRA3129070</b>	
80	M90x3,5	<b>ZRA3129080</b>	
80	M102x4	<b>ZRA31210280</b>	
100	M125x4	<b>ZRA312125100</b>	

**Tuercas Macon**



Écrous à crans Macon  
Macon nuts  
Dadi Macon

DN	ROSCA THREAD	REFERENCIA PART N°	€
40	M55x3	<b>ZMAC H 40</b>	
50	M65x3	<b>ZMAC H 50</b>	
60	M79x3,5	<b>ZMAC H 60</b>	
70	M90x3,5	<b>ZMAC H 70</b>	
80	M102x4	<b>ZMAC H 80</b>	
100	M125x4	<b>ZMAC H 100</b>	

## Industria alimentaria

Raccords alimentaires  
Food industry  
Raccordi alimentari

Crimp fittings for hoses

Pipe fittings DIN 2353

Flare fittings JIC  
SAE flanges

Adaptors

Welding fittings

Industrial fittings

Several items

### Hembra giratoria prensar SMS para PTFE corrugado Serie STD

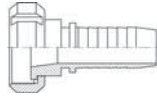

Femelle tournante SMS pour PTFE convoluted Série STD  
Swivel female SMS for convoluted PTFE STD Series  
Femmina girevole SMS per tubo PTFE corrugato Serie STD

DN	ROSCA THREAD	REFERENCIA PART N°	€
1"	40x1/6"	ZRA2504016	
1" 1/4	48x1/6"	ZRA2504820	
1" 1/2	60x1/6"	ZRA2506024	
2"	70x1/6"	ZRA2507032	
2" 1/2	85x1/6"	ZRA2508540	

### Machos SMS para PTFE corrugado Serie STD



Raccord mâle SMS pour PTFE convoluted Série STD  
Fixed male SMS for convoluted PTFE hose STD Series  
Maschio girevole SMS per tubo PTFE corrugato Serie STD

DN	ROSCA THREAD	REFERENCIA PART N°	€
1"	40x1/6"	ZRA2524016	
1" 1/4	48x1/6"	ZRA2524820	
1" 1/2	60x1/6"	ZRA2526024	
2"	70x1/6"	ZRA2527032	
2" 1/2	85x1/6"	ZRA2528540	

### Machos DIN 11851 para PTFE corrugado Serie STD

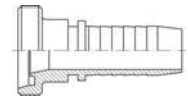

Raccord mâle DIN 11851 pour PTFE convoluted Série STD  
Fixed male DIN 11851 for convoluted PTFE hose STD Series  
Maschio DIN 11851 per tubo PTFE corrugato Serie STD

DN	ROSCA THREAD	REFERENCIA PART N°	€
1"	52x1/6"	ZRA1525216	
1" 1/4	58x1/6"	ZRA1525820	
1" 1/2	65x1/6"	ZRA1526524	
2"	78x1/6"	ZRA1527832	
2" 1/2	95x1/6"	ZRA1529540	

### Hembra giratoria DIN 11851 para PTFE corrugado Serie STD

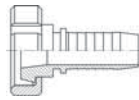

Raccord femelle tournante DIN 11851 pour PTFE convoluted Série STD  
Swivel female DIN 11851 for convoluted PTFE hose STD Series  
Femmina girevole DIN 11851 per tubo PTFE corrugato Serie STD

DN	ROSCA THREAD	REFERENCIA PART N°	€
1"	52x1/6"	ZRA1505216	
1" 1/4	58x1/6"	ZRA1505820	
1" 1/2	65x1/6"	ZRA1506524	
2"	78x1/6"	ZRA1507832	
2" 1/2	95x1/6"	ZRA1509540	

### Casquillos PTFE corrugado

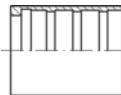

Jupes PTFE convoluté  
Ferrules for convoluted PTFE  
Boccola pressare per PTFE corrugato

DN	REFERENCIA PART N°	€
1/4"	810410400	
5/16"	810410500	
3/8"	810410600	
1/2"	810410800	
5/8"	810411000	
3/4"	810411201	
1"	810411600	
1" 1/4	810412000	
1" 1/2	810412400	
2"	810413200	
2" 1/2	810414000	

**Hembra giratoria prensar SMS para PTFE corrugado**

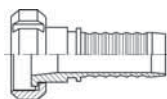

Femelle tournante SMS pour PTFE convoluté

Swivel female SMS for convoluted PTFE

Femmina girevole a pressione SMS per tubo corrugato PTFE

DN	ROSCA THREAD	REFERENCIA PART N°	€
1"	40x1/6"	ZRA5004016	
1"1/4	48x1/6"	ZRA5004820	
1"1/2	60x1/6"	ZRA5006024	
2"	70x1/6"	ZRA5007032	

\*Hasta fin de existencias/\*\*Jusqu'à la fin du stock/\*\*Until end of stock/\*\*Fino ad esaurimento scorta

**Machos DIN 11851 para PTFE corrugado**

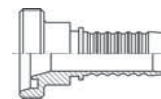

Raccord mâle DIN 11851 PTFE convoluté

Fixed male DIN 11851 for convoluted PTFE hose

Maschio fisso DIN 11851 per tubo corrugato PTFE

DN	ROSCA THREAD	REFERENCIA PART N°	€
1"	52x1/6"	ZRA4125216	
1"1/4	58x1/6"	ZRA4125820	
1"1/2	65x1/6"	ZRA4126524	
2"	78x1/6"	ZRA4127832	

\*Hasta fin de existencias/\*\*Jusqu'à la fin du stock/\*\*Until end of stock/\*\*Fino ad esaurimento scorta

**Casquillos PTFE corrugado para racores alimentarios**

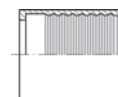

Jupes PTFE convoluté pour raccords alimentaires

Convoluted PTFE ferrules for food fittings

Boccola a pressione Teflon corrugato per raccordi alimentari

DN	REFERENCIA PART N°	€
1"	810501600	
1" 1/4	810502000	
1" 1/2	810502400	
2"	810503200	

\*Hasta fin de existencias/\*\*Jusqu'à la fin du stock/\*\*Until end of stock/\*\*Fino ad esaurimento scorta

**Machos SMS para PTFE corrugado**

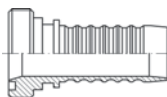

Raccord mâle SMS PTFE convoluté

Fixed male SMS for convoluted PTFE hose

Maschio fisso SMS per tubo corrugato PTFE

DN	ROSCA THREAD	REFERENCIA PART N°	€
1"	40x1/6"	ZRA5124016	
1"1/4	48x1/6"	ZRA5124820	
1"1/2	60x1/6"	ZRA5126024	
2"	70x1/6"	ZRA5127032	

\*Hasta fin de existencias/\*\*Jusqu'à la fin du stock/\*\*Until end of stock/\*\*Fino ad esaurimento scorta

**Hembra giratoria DIN 11851 para PTFE corrugado**

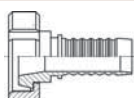

Raccord femelle tournante DIN 11851 PTFE convoluté

Swivel female DIN 11851 for convoluted PTFE hose

Femmina girevole DIN 11851 per tubo corrugato PTFE

DN	ROSCA THREAD	REFERENCIA PART N°	€
1"	52x1/6"	ZRA4005216	
1"1/4	58x1/6"	ZRA4005820	
1"1/2	65x1/6"	ZRA4006524	
2"	78x1/6"	ZRA4007832	

\*Hasta fin de existencias/\*\*Jusqu'à la fin du stock/\*\*Until end of stock/\*\*Fino ad esaurimento scorta

## Camlock AISI 316 - DIN 2828

Raccords Camlock AISI 316 - DIN 2828

Camlock AISI 316 - DIN 2828

Camlock AISI 316 - DIN 2828

### Adaptador macho - rosca hembra Tipo A



Adaptateur mâle - filetage femelle Type A

Adaptor, female threaded Type A

Adattatore maschio-filettatura femmina Tipo A

DN	ROSCA THREAD	REFERENCIA PART N°	€
12	1/2"	ZA012	
15	1/2"	ZA015	
20	3/4"	ZA020	
25	1"	ZA025	
32	1"1/4	ZA032	
40	1"1/2	ZA040	
50	2"	ZA050	
65	2"1/2	ZA065	
80	3"	ZA080	
100	4"	ZA100	

### Adaptator hembra Tipo D



Adaptateur femelle Type D

Coupling, female threaded Type D

Adattatore femmina Tipo D

DN	ROSCA THREAD	REFERENCIA PART N°	€
12	1/2"	ZD012	
15	1/2"	ZD015	
20	3/4"	ZD020	
25	1"	ZD025	
32	1"1/4	ZD032	
40	1"1/2	ZD040	
50	2"	ZD050	
65	2"1/2	ZD065	
80	3"	ZD080	
100	4"	ZD100	

### Adaptador hembra - rosca macho Tipo B



Adaptateur femelle - filetage mâle Type B

Coupling, female threaded Type B

Adattatore femmina-filettatura maschio Tipo B

DN	ROSCA THREAD	REFERENCIA PART N°	€
12	1/2"	ZB012	
15	1/2"	ZB015	
20	3/4"	ZB020	
25	1"	ZB025	
32	1"1/4	ZB032	
40	1"1/2	ZB040	
50	2"	ZB050	
65	2"1/2	ZB065	
80	3"	ZB080	
100	4"	ZB100	

### Conexión macho para manguera Tipo E



Coupleur mâle Type E

Adaptor, with serrated hose shank Type E

Adattatore con inserto per Tipo E

DN	REFERENCIA PART N°	€
1/2"	12	ZE012
1/2"	15	ZE015
3/4"	20	ZE020
1"	25	ZE025
1"1/4	32	ZE032
1"1/2	40	ZE040
2"	50	ZE050
2"1/2	65	ZE065
3"	80	ZE080
4"	100	ZE100

### Conexión hembra para manguera Tipo C



Coupleur femelle Type C

Coupling with serrated hose shank Type C

Adattatore con inserto per tubo Tipo C

DN	REFERENCIA PART N°	€
1/2"	12	ZC012
1/2"	15	ZC015
3/4"	20	ZC020
1"	25	ZC025
1"1/4	32	ZC032
1"1/2	40	ZC040
2"	50	ZC050
2"1/2	65	ZC065
3"	80	ZC080
4"	100	ZC100

### Adaptador macho Tipo F



Adaptateur mâle Type F

Adaptor, male threaded Type F

Adattatore maschio Tipo F

DN	ROSCA THREAD	REFERENCIA PART N°	€
12	1/2"	ZF012	
15	1/2"	ZF015	
20	3/4"	ZF020	
25	1"	ZF025	
32	1"1/4	ZF032	
40	1"1/2	ZF040	
50	2"	ZF050	
65	2"1/2	ZF065	
80	3"	ZF080	
100	4"	ZF100	

# Camlock AISI 316 - DIN 2828

Raccords Camlock AISI 316 - DIN 2828

Camlock AISI 316 - DIN 2828

Camlock AISI 316 - DIN 2828

## Tapón hembra Tipo DC



Bouchon femelle Type DC  
Dust caps Type DC  
Tappo di protezione Tipo DC

DN	REFERENCIA PART N°	€
12	ZDC012	
20	ZDC020	
25	ZDC025	
32	ZDC032	
40	ZDC040	
50	ZDC050	
65	ZDC065	
80	ZDC080	
100	ZDC100	

## Tapón macho tipo DP



Bouchon mâle Type DP  
Dust plugs Type DP  
Cappuccio di protezione Tipo DP

DN	REFERENCIA PART N°	€
12	ZDP012	
20	ZDP020	
25	ZDP025	
32	ZDP032	
40	ZDP040	
50	ZDP050	
65	ZDP065	
80	ZDP080	
100	ZDP100	

## Junta Camlock NBR



Joint Camlock NBR  
Camlock NBR Seal  
Guarnizione in NBR per Camlock

DN	REFERENCIA PART N°	€
12	JCAMNBR012	
20	JCAMNBR020	
25	JCAMNBR025	
32	JCAMNBR032	
40	JCAMNBR040	
50	JCAMNBR050	
65	JCAMNBR065	
80	JCAMNBR080	
100	JCAMNBR100	

## Junta Camlock silicona



Joint Camlock silicone  
Camlock silicone seal  
Guarnizione in silicone per Camlock

DN	REFERENCIA PART N°	€
12	JCAMS012	
20	JCAMS020	
25	JCAMS025	
32	JCAMS032	
40	JCAMS040	
50	JCAMS050	
65	JCAMS065	
80	JCAMS080	
100	JCAMS100	

## Racores baja presión 150 LBS

Raccords basse pression 150 LBS  
Screwed fittings low pressure 150 LBS  
Raccordi bassa pressione 150 LBS

### Macho fijo espiga FIG.399

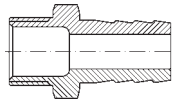

Mâle fixe nipple fig. 399 inox  
Nipple fixed male fig.399  
Niples m-m fisiso fig. 399 inox

DN	ROSCA THREAD	REFERENCIA PART N°	€
10	1/4"	ZFIG39904	
12	3/8"	ZFIG39906	
15	1/2"	ZFIG39908	
20	3/4"	ZFIG39912	
25	1"	ZFIG39916	
32	1" 1/4	ZFIG39920	
40	1" 1/2	ZFIG39924	
52	2"	ZFIG39932	

### Adaptador hexagonal FIG.280



Mamelon hexagonal 150 LBS FIG.280  
Hexagon nipple FIG.280  
Niples esagonale FIG.280

ROSCA THREAD	REFERENCIA PART N°	€
1/4"	ZFIG28004	
3/8"	ZFIG28006	
1/2"	ZFIG28008	
3/4"	ZFIG28012	
1"	ZFIG28016	
1"1/4	ZFIG28020	
1"1/2	ZFIG28024	
2"	ZFIG28032	
2"1/2	ZFIG28040	
3"	ZFIG28048	
4"	ZFIG28060	

### Unión macho-macho FIG.150



Union mâle-mâle fig.150 inox  
Union male-male fig.150  
Unione maschio-maschio fig.150 inox

ROSCA THREAD	REFERENCIA PART N°	€
1/4"	ZFIG15004	
3/8"	ZFIG15006	
1/2"	ZFIG15008	
3/4"	ZFIG15012	
1"	ZFIG15016	
1" 1/4	ZFIG15020	
1" 1/2	ZFIG15024	
2"	ZFIG15032	

### Reducción macho-macho FIG.245

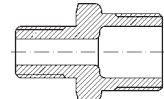

Réduction mâle-mâle fig. 245 inox  
Reducer male-male fig. 245  
Riduzione maschio-maschio fig. 245 inox

ROSCA THREAD	ROSCA THREAD	REFERENCIA PART N°	€
1/4"	1/8"	ZFIG2450402	
3/8"	1/4"	ZFIG2450604	
1/2"	1/4"	ZFIG2450804	
1/2"	3/8"	ZFIG2450806	
3/4"	3/8"	ZFIG2451206	
3/4"	1/2"	ZFIG2451208	
1"	1/2"	ZFIG2451608	
1"	3/4"	ZFIG2451612	
1" 1/4	3/4"	ZFIG2452012	
1" 1/2	1"	ZFIG2452416	
1"1/2	1" 1/4	ZFIG2452420	
2"	1" 1/4	ZFIG2453220	
2"	1" 1/2	ZFIG2453224	
2" 1/2	2"	ZFIG2454032	
3"	2" 1/2	ZFIG2454840	

### Tapón macho hexagonal FIG.290



Bouchon mâle 150 LBS tête hexagonale FIG.290  
Hexagon male plug FIG.290  
Tappo maschio esagonale FIG.290

ROSCA THREAD	REFERENCIA PART N°	€
1/8"	ZFIG29002	
1/4"	ZFIG29004	
3/8"	ZFIG29006	
1/2"	ZFIG29008	
3/4"	ZFIG29012	
1"	ZFIG29016	
1"1/4	ZFIG29020	
1"1/2	ZFIG29024	
2"	ZFIG29032	
2"1/2	ZFIG29040	
3"	ZFIG29048	
4"	ZFIG29060	

### Tuerca plana FIG.312

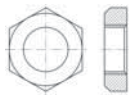

Écrou plat fig.312 inox  
Flat nut fig.312  
Dado piano fig.312 inox

ROSCA THREAD	REFERENCIA PART N°	€
1/4"	ZFIG31204	
3/8"	ZFIG31206	
1/2"	ZFIG31208	
3/4"	ZFIG31212	
1"	ZFIG31216	
1" 1/4	ZFIG31220	
1" 1/2	ZFIG31224	
2"	ZFIG31232	



## Racores baja presión 150 LBS

Raccords basse pression 150 LBS  
Screwed fittings low pressure 150 LBS  
Raccordi bassa pressione 150 LBS

### Tapón hembra hexagonal FIG.300

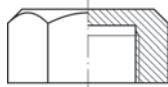

Bouchon femelle hexagonal 150 LBS FIG.300

Hexagon female cap FIG.300

Tappo femmina esagonale FIG.300

ROSCA THREAD	REFERENCIA PART N°	€
1/8"	ZFIG30002	
1/4"	ZFIG30004	
3/8"	ZFIG30006	
1/2"	ZFIG30008	
3/4"	ZFIG30012	
1"	ZFIG30016	
1"1/4	ZFIG30020	
1"1/2	ZFIG30024	
2"	ZFIG30032	
2"1/2	ZFIG30040	
3"	ZFIG30048	
4"	ZFIG30060	

### Adaptador hembra BSP DIN 2986 FIG.270

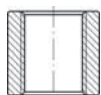

Manchon femelle gaz DIN 2986 150 LBS FIG.270

BSP Female coupling DIN 2986 FIG.270

Adattatore femmina BSP DIN 2986 FIG.270

ROSCA THREAD	REFERENCIA PART N°	€
1/4"	ZFIG27004	
3/8"	ZFIG27006	
1/2"	ZFIG27008	
3/4"	ZFIG27012	
1"	ZFIG27016	
1"1/4	ZFIG27020	
1"1/2	ZFIG27024	
2"	ZFIG27032	
2"1/2	ZFIG27040	
3"	ZFIG27048	
4"	ZFIG27060	

### Tapón macho cuadrado FIG.291

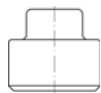

Bouchon mâle 150 LBS tête carrée FIG.291

Male square plug FIG.291

Tappo maschio testa quadrata FIG.291

ROSCA THREAD	REFERENCIA PART N°	€
1/8"	ZFIG29102	
1/4"	ZFIG29104	
3/8"	ZFIG29106	
1/2"	ZFIG29108	
3/4"	ZFIG29112	
1"	ZFIG29116	
1"1/4	ZFIG29120	
1"1/2	ZFIG29124	
2"	ZFIG29132	
2"1/2	ZFIG29140	
3"	ZFIG29148	
4"	ZFIG29160	

### Tapón hembra redondo FIG.301

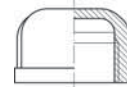

Bouchon femelle ronde 150 LBS FIG.301

Round female cap FIG.301

Tappo femmina rotondo FIG.301

ROSCA THREAD	REFERENCIA PART N°	€
1/8"	ZFIG30102	
1/4"	ZFIG30104	
3/8"	ZFIG30106	
1/2"	ZFIG30108	
3/4"	ZFIG30112	
1"	ZFIG30116	
1"1/4	ZFIG30120	
1"1/2	ZFIG30124	
2"	ZFIG30132	
2"1/2	ZFIG30140	
3"	ZFIG30148	
4"	ZFIG30160	

\*Hasta fin de existencias/\*\*Jusqu'à la fin du stock/\*\*Until end of stock/\*\*Fino ad esaurimento scorta

### Reducción hembra-hembra FIG.240



Réduction 150 LBS FIG.240

Reducer socket FIG.240

Riduzione femmina-femmina FIG.240

ROSCA THREAD	REFERENCIA PART N°	€
1/4"	1/8"	ZFIG2400402
3/8"	1/4"	ZFIG2400604
1/2"	3/8"	ZFIG2400806
3/4"	1/2"	ZFIG2401208
1"	3/4"	ZFIG2401612
1"1/4	1"	ZFIG2402016
1"1/2	1"1/4	ZFIG2402420
2"	1"1/2	ZFIG2403224
2"1/2	2"	ZFIG2404032
3"	2"	ZFIG2404832
3"	2"1/2	ZFIG2404840
4"	2"	ZFIG2406032

### Reductor macho-hembra FIG.241

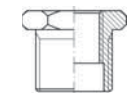

Réduction 150 LBS MG - FG FIG.241

Male-female reducer FIG.241

Riduzione maschio-femmina FIG.241

ROSCA THREAD	REFERENCIA PART N°	€
1/8"	1/4"	ZFIG2410204
1/4"	3/8"	ZFIG2410406
1/4"	1/2"	ZFIG2410408
3/8"	1/2"	ZFIG2410608
1/2"	3/4"	ZFIG2410812
3/4"	1"	ZFIG2411216
1"	1"1/4	ZFIG2411620
1"1/4	1"1/2	ZFIG2412024
1"1/2	2"	ZFIG2412432
2"	2"1/2	ZFIG2413240
2"1/2	3"	ZFIG2414048
3"	4"	ZFIG2414860

## Racores baja presión 150 LBS

Raccords basse pression 150 LBS  
Screwed fittings low pressure 150 LBS  
Raccordi bassa pressione 150 LBS

Crimp fittings for hoses

Pipe fittings DIN 2353

Flare fittings JIC  
SAE flanges

Adaptors

Welding fittings

Industrial fittings

Several items

### Codo 90° hembra-hembra FIG.090

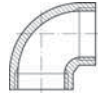

Coude 90° 150 LBS femelle gaz FIG.090  
Female-female elbow 90° FIG.090  
Curva 90° femmina-femmina FIG.090

ROSCA THREAD	REFERENCIA PART N°	€
1/8"	ZFIG09002	
1/4"	ZFIG09004	
3/8"	ZFIG09006	
1/2"	ZFIG09008	
3/4"	ZFIG09012	
1"	ZFIG09016	
1"1/4	ZFIG09020	
1"1/2	ZFIG09024	
2"	ZFIG09032	
2"1/2	ZFIG09040	
3"	ZFIG09048	
4"	ZFIG09060	

### Codo 90° macho-hembra FIG.092

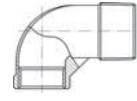

Coude 90° 150 LBS MG - FG FIG.092  
Male-female elbow 90° FIG.092  
Adattatore a 90° maschio-femmina FIG.092

ROSCA THREAD	REFERENCIA PART N°	€
1/8"	ZFIG09202	
1/4"	ZFIG09204	
3/8"	ZFIG09206	
1/2"	ZFIG09208	
3/4"	ZFIG09212	
1"	ZFIG09216	
1"1/4	ZFIG09220	
1"1/2	ZFIG09224	
2"	ZFIG09232	
2"1/2	ZFIG09240	
3"	ZFIG09248	
4"	ZFIG09260	

### Codo 45° hembra-hembra FIG.120



Coude 45° 150 LBS FG - FG FIG.120  
Female-female elbow 45° FIG.120  
Adattatore a 45° femmina-femmina

ROSCA THREAD	REFERENCIA PART N°	€
1/8"	ZFIG12002	
1/4"	ZFIG12004	
3/8"	ZFIG12006	
1/2"	ZFIG12008	
3/4"	ZFIG12012	
1"	ZFIG12016	
1"1/4	ZFIG12020	
1"1/2	ZFIG12024	
2"	ZFIG12032	
2"1/2	ZFIG12040	
3"	ZFIG12048	
4"	ZFIG12060	

### TE hembra-hembra-hembra FIG.130

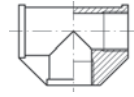

TÉS 150 LBS FG - FG - FG FIG.130  
F - F - F TEES FIG.130  
Adattatore a T F - F - F

ROSCA THREAD	REFERENCIA PART N°	€
1/8"	ZFIG13002	
1/4"	ZFIG13004	
3/8"	ZFIG13006	
1/2"	ZFIG13008	
3/4"	ZFIG13012	
1"	ZFIG13016	
1"1/4	ZFIG13020	
1"1/2	ZFIG13024	
2"	ZFIG13032	
2"1/2	ZFIG13040	
3"	ZFIG13048	
4"	ZFIG13060	

### Cruz roscada FIG.180

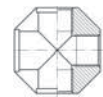

Croix égale 150 LBS FG FIG.180  
Threaded cross FIG.180  
Croce filettata femmina FIG.180

ROSCA THREAD	REFERENCIA PART N°	€
1/8"	ZFIG18002	
1/4"	ZFIG18004	
3/8"	ZFIG18006	
1/2"	ZFIG18008	
3/4"	ZFIG18012	
1"	ZFIG18016	
1"1/4	ZFIG18020	
1"1/2	ZFIG18024	
2"	ZFIG18032	
2"1/2	ZFIG18040	
3"	ZFIG18048	
4"	ZFIG18060	

### Tubo roscado FIG.531



Tube fileté fig. 531 inox  
Threaded pipe fig. 531  
Tubo filettato fig. 531 inox

ROSCA THREAD	REFERENCIA PART N°	€
1/4"	ZFIG53104	
3/8"	ZFIG53106	
1/2"	ZFIG53108	
3/4"	ZFIG53112	
1"	ZFIG53116	
1" 1/4	ZFIG53120	
1" 1/2	ZFIG53124	
2"	ZFIG53132	

## Racores baja presión 150 LBS

Raccords basse pression 150 LBS  
Screwed fittings low pressure 150 LBS  
Raccordi bassa pressione 150 LBS

### Unión 3 piezas hembra-hembra FIG.340

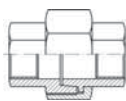

Union 3 pièces 150 LBS FG - FG FIG.340  
Female-female FIG.340  
Unione femmina-femmina FIG.340

ROSCA THREAD	REFERENCIA PART N°	€
1/8"	ZFIG34002	
1/4"	ZFIG34004	
3/8"	ZFIG34006	
1/2"	ZFIG34008	
3/4"	ZFIG34012	
1"	ZFIG34016	
1"1/4	ZFIG34020	
1"1/2	ZFIG34024	
2"	ZFIG34032	
2"1/2	ZFIG34040	
3"	ZFIG34048	
4"	ZFIG34060	

### Unión 3 piezas macho-hembra FIG.341

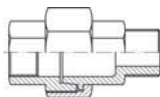

Union 3 pièces 150 LBS MG - FG FIG.341  
Male-female union FIG.341  
Unione maschio-femmina FIG:341

ROSCA THREAD	REFERENCIA PART N°	€
1/4"	ZFIG34104	
3/8"	ZFIG34106	
1/2"	ZFIG34108	
3/4"	ZFIG34112	
1"	ZFIG34116	
1"1/4	ZFIG34120	
1"1/2	ZFIG34124	
2"	ZFIG34132	
2"1/2	ZFIG34140	
3"	ZFIG34148	
4"	ZFIG34160	

### Válvula esfera paso total baja presión 70 Bar

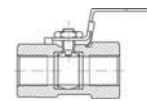

Robinet basse pression 2 voies boisseau sphérique passage total 70 Bar  
Ball-valve low pressure full bore 70 Bar  
Rubinetto a sfera bassa pressione passaggio totale 70 Bar

DN	ROSCA THREAD	REFERENCIA PART N°	€
8	1/4" BSP	BP2V14INOX	
10	3/8" BSP	BP2V38INOX	
15	1/2" BSP	BP2V12INOX	
20	3/4" BSP	BP2V34INOX	
25	1" BSP	BP2V1INOX	
32	1"1/4 BSP	BP2V114INOX	
40	1"1/2 BSP	BP2V112INOX	
50	2" BSP	BP2V2INOX	
65	2"1/2 BSP	BP2V212INOX	
80	3" BSP	BP2V3INOX	

### Válvula esfera paso total baja presión 3 piezas



Robinet basse pression 2 voies boisseau sphérique passage total 3 pcs  
Ball-valve low pressure full bore 3 pcs  
Rubinetto a sfera bassa pressione 3 pcs

ROSCA THREAD	REFERENCIA PART N°	€
1/4 BSP	BP2V3P14INOX	
3/8 BSP	BP2V3P38INOX	
1/2 BSP	BP2V3P12INOX	
3/4 BSP	BP2V3P34INOX	
1" BSP	BP2V3P1INOX	
1" 1/4 BSP	BP2V3P114INOX	
1" 1/2 BSP	BP2V3P112INOX	
2" BSP	BP2V3P2INOX	

## Racores baja presión 150 LBS

Raccords basse pression 150 LBS  
Screwed fittings low pressure 150 LBS  
Raccordi bassa pressione 150 LBS

Crimp fittings for hoses

Pipe fittings DIN 2353

Flare fittings JIC  
SAE flanges

Adaptors

Welding fittings

Industrial fittings

Several items

### Unión 3 piezas hembra-soldar FIG.340HS microfundido

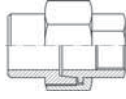

Union 3 pcs fem. à souder fig.340hs acier moulé  
Union 3 fem. welding pieces fig.340hs micro-casting  
Unione a 3 pezzi f.saldare fig.340hs microfusione

ROSCA THREAD	REFERENCIA PART N°	€
1/4"	ZFIG34004HS	
3/8"	ZFIG34006HS	
1/2"	ZFIG34008HS	
3/4"	ZFIG34012HS	
1"	ZFIG34016HS	
1" 1/4	ZFIG34020HS	
1" 1/2	ZFIG34024HS	
2"	ZFIG34032HS	

### Unión 3 piezas macho-soldar FIG.341MS microfundido

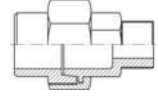

Union 3 pcs mâle à souder fig.341ms acier moulé  
Union 3 welding male pieces fig.341ms micro-casting  
Unione a 3 pezzi m.saldare fig.341ms microfusione

ROSCA THREAD	REFERENCIA PART N°	€
1/4"	ZFIG34104MS	
3/8"	ZFIG34106MS	
1/2"	ZFIG34108MS	
3/4"	ZFIG34112MS	
1"	ZFIG34116MS	
1" 1/4	ZFIG34120MS	
1" 1/2	ZFIG34124MS	
2"	ZFIG34132MS	

### Unión 3 piezas soldar FIG.340S microfundido

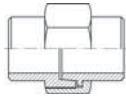

Union 3 pièces à souder fig. 340s acier moulé  
Union 3 welding pieces fig. 340s micro-casting  
Unione a 3 pezzi a saldare fig.340s microfusione

DN	REFERENCIA PART N°	€
1/4	ZFIG34004S	
3/8	ZFIG34006S	
1/2	ZFIG34008S	
3/4	ZFIG34012S	
1	ZFIG34016S	
1 1/4	ZFIG34020S	
1 1/2	ZFIG34024S	
2	ZFIG34032S	

## Enchufes, Llaves y Componentes Hidráulicos

Coupleurs, Robinets et Composants  
Hydrauliques

Couplings, Ball valves and Hydraulic  
Components

Innesti rapidi, Rubinetti a sfera e Componenti  
Idraulici

- ▶ Enchufes rápidos AISI 316 188  
Coupleurs rapides AISI 316 | Quick couplings AISI 316 | Innesti rapidi AISI 316
- ▶ Llaves de paso AISI 316 189  
Robinets AISI 316 | Ball valves AISI 316 | Rubinetti AISI 316
- ▶ Enchufes, Llaves y Racores Giratorios TrAle 190  
Coupleurs rapides, robinets et raccords tournants TrAle | Quick couplings, ball valves and swivel fittings TrAle | Innesti rapidi, rubinetti e giunti girevole TrAle
- ▶ Componentes hidráulicos AISI 316 191  
Composants Hydrauliques AISI 316 | Hydraulic Components AISI 316 | Componenti Idraulici AISI 316
- ▶ Manómetros AISI 316L con glicerina 192  
Manomètre AISI 316L avec glycérine | Manometers AISI 316L with glycerin | Manometri AISI 316 a bagno di glicerina

# Enchufes rápidos AISI 316

Coupleurs rapides AISI 316 | Quick couplings AISI 316 | Innesti rapidi AISI 316

Crimp fittings for hoses

Pipe fittings DIN 2353

Flare fittings JIC  
SAE flanges

Adaptors

Welding fittings

Industrial fittings

Several items

## Enchufes rápidos | Quick release couplings | Quick couplings | Innesti rapidi

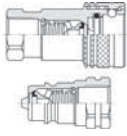

Z8001/Z8002

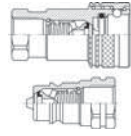

Z8201/Z8202



Z8301/Z8302



Z9001/Z9002



Z8008/Z8009

# Llaves de paso AISI 316

Robinets AISI 316 | Ball valves AISI 316 | Rubinetti AISI 316

## Llaves de paso | Robinets | Ball valves | Rubinetti

194

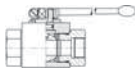

MKH G

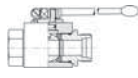

MKH\_L

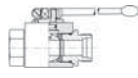

MKH\_S

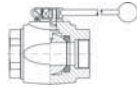

MKH G\_DN

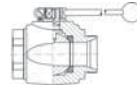

MKH\_L\_DN

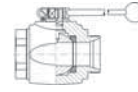

MKH\_S\_DN

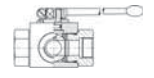

MK3A-G

## Enchufes, Llaves y Racores Giratorios TrAle

Coupleurs rapides, robinets et raccords tournants TrAle | Quick couplings, ball valves and swivel fittings TrAle | Innesti rapidi, rubinetti e giunti girevole TrAle

Crimp fittings for hoses

Pipe fittings DIN 2353

Flare fittings JIC  
SAE flanges

Adaptors

Welding fittings

Industrial fittings

Several items

### ▶ Enchufes rápidos TrAle | Coupleurs rapides TrAle | Quick couplings TrAle | Innesti rapidi TrAle

196

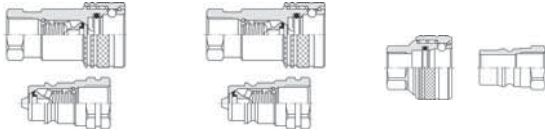

ZB8001/ZB8002

ZB8201/ZB8202

ZB8301/ZB8302

### ▶ Llaves de paso TrAle | Robinets TrAle | Ball valves TrAle | Rubinetti TrAle

196



ZGB2V

ZGB2V L

ZGB2V S

### ▶ Racores Giratorios TrAle | Raccords tournants TrAle | Swivel fittings TrAle | Giunti girevole TrAle

197



Z GGL

Z GG90



## Componentes hidráulicos AISI 316

Composants Hydrauliques AISI 316 | Hydraulic Components AISI 316 | Componenti Idraulici AISI 316

### ▶ **Reguladores caudal** | Régulateurs de débit | Flow control valves | Regolatori di flusso

198



ZFT2251B



ZFT2253U

### ▶ **Protectores manómetro AISI 316** | Valves pour manomètres | Valves for manometers | Esclusori per manometro

198



Z FPE



Z FPEA

### ▶ **Anti-retornos** | Clapet antiretour | Check-valves | Valvole di ritegno

198



Z FPR

Crimp fittings for hoses

Pipe fittings DIN 2353

Flare fittings JIC  
SAE flanges

Adaptors

Welding fittings

Industrial fittings

Several items

## Manómetros AISI 316L con glicerina

Manomètre AISI 316L avec glycérine | Manometers AISI 316L with glycerin | Manometri AISI 316 a bagno di glicerina

Crimp fittings for hoses

Pipe fittings DIN 2353

Flare fittings JIC  
SAE flanges

Adaptors

Welding fittings

Industrial fittings

Several items

### ▶ **Manómetros inox glicerina DN 63** | Manomètre avec glycérine DN 63 | Manometer DN 63 with glycerin | Manometro DN 63 a bagno di glicerina 199



ZMFI63..V



ZMFI63..DB

### ▶ **Manómetros inox glicerina DN 100** | Manomètre avec glycérine DN 100 | Manometer DN 100 with glycerin | Manometro DN 100 a bagno di glicerina 199



ZMFI100..V



ZMFI100DB

## Enchufes rápidos AISI 316

Coupleurs rapides AISI 316

Quick couplings AISI 316

Innesti rapidi AISI 316

### Enchufes de punzón ISO B



Coupleurs rapides à clapet

Quick coupling ISO B

Innesti a valvola ISO B

DN	ROSCA THREAD	E. C.	REFERENCIA PART N°	€
6	1/4" BSP	M	Z800104	
10	3/8" BSP	M	Z800106	
13	1/2" BSP	M	Z800108	
20	3/4" BSP	M	Z800112	
25	1" BSP	M	Z800116	
39	1 1/4" BSP	M	Z800120	
39	1 1/2" BSP	M	Z800124	
50	2" BSP	M	Z800132	
6	1/4" BSP	H	Z800204	
10	3/8" BSP	H	Z800206	
13	1/2" BSP	H	Z800208	
20	3/4" BSP	H	Z800212	
25	1" BSP	H	Z800216	
39	1 1/4" BSP	H	Z800220	
39	1 1/2" BSP	H	Z800224	
50	2" BSP	H	Z800232	

### Enchufes de punzón ISO A



Coupleurs rapides à clapet ISO A

Quick coupling ISO A

Innesti a valvola ISO A

DN	ROSCA THREAD	E. C.	REFERENCIA PART N°	€
7	3/8" BSP	M	Z820106	
10	1/2" BSP	M	Z820108	
13.2	3/4" BSP	M	Z820112	
16.9	1" BSP	M	Z820116	
7	3/8" BSP	H	Z820206	
10	1/2" BSP	H	Z820208	
13.2	3/4" BSP	H	Z820212	
16.9	1" BSP	H	Z820216	

### Enchufes paso total

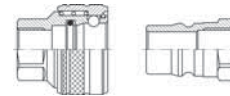

Coupleurs rapides à clapet passage total

Quick coupling free flow

Innesti a passaggio libero

DN	ROSCA THREAD	E. C.	REFERENCIA PART N°	€
4	1/8" BSP	M	Z830102	
6	1/4" BSP	M	Z830104	
10	3/8" BSP	M	Z830106	
13	1/2" BSP	M	Z830108	
20	3/4" BSP	M	Z830112	
25	1" BSP	M	Z830116	
39	1 1/4" BSP	M	Z830120	
39	1 1/2" BSP	M	Z830124	
50	2" BSP	M	Z830132	
4	1/8" BSP	H	Z830202	
6	1/4" BSP	H	Z830204	
10	3/8" BSP	H	Z830206	
13	1/2" BSP	H	Z830208	
20	3/4" BSP	H	Z830212	
25	1" BSP	H	Z830216	
39	1 1/4" BSP	H	Z830220	
39	1 1/2" BSP	H	Z830224	
50	2" BSP	H	Z830232	

### Enchufes de válvula plana



Coupleurs à clapet face plane

Flat face quick coupling

Innesti a faccia piana

DN	ROSCA THREAD	E. C.	REFERENCIA PART N°	€
6	1/4" BSP	M	Z900104	
13	3/8" BSP	M	Z900106	
13	1/2" BSP	M	Z900108	
20	3/4" BSP	M	Z900112	
25	1" BSP	M	Z900116	
6	1/4" BSP	H	Z900204	
13	3/8" BSP	H	Z900206	
13	1/2" BSP	H	Z900208	
20	3/4" BSP	H	Z900212	
25	1" BSP	H	Z900216	

### Enchufes auto-roscantes



Coupleur rapide à visser filetage

Quick screw couplings

Innesti rapidi a vite

DN	ROSCA THREAD	E. C.	REFERENCIA PART N°	€
10	3/8" BSP	M	Z800806	
13	1/2" BSP	M	Z800808	
20	3/4" BSP	M	Z800812	
25	1" BSP	M	Z800816	
10	3/8" BSP	H	Z800906	
13	1/2" BSP	H	Z800908	
20	3/4" BSP	H	Z800912	
25	1" BSP	H	Z800916	

## Llaves de paso AISI 316

Robinets AISI 316  
Ball valves AISI 316  
Rubinetti AISI 316

Crimp fittings for hoses

Pipe fittings DIN 2353

Flare fittings JIC  
SAE flanges

Adaptors

Welding fittings

Industrial fittings

Several items

### Llave 2 vías rosca hembra BSP

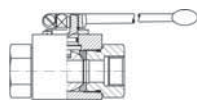

Robinet haute pression 2 voies boisseau sphérique femelle BSP  
2 Way ball-valves BSP female ISO 228  
Rubinetto a sfera femmina - femmina BSP

DN	ROSCA THREAD	REFERENCIA PART N°	€
4	1/8" BSP	MKH G 1/8	
6	1/4" BSP	MKH G 1/4	
10	3/8" BSP	MKH G 3/8	
13	1/2" BSP	MKH G 1/2	
16	5/8" BSP	MKH G 5/8	
20	3/4" BSP	MKH G 3/4	
25	1" BSP	MKH G 1	
25	1" 1/4 BSP	MKH G 1 1/4 DN25	
25	1" 1/2 BSP	MKH G 1 1/2 DN25	
50	2" BSP	MKH G 2	

### Llave 2 vías rosca hembra BSP paso total

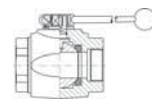

Robinet haute pression 2 voies boisseau sphérique femelle  
Ball-valves BSP female  
Rubinetto a sfera femmina - femmina BSP

DN	ROSCA THREAD	REFERENCIA PART N°	€
32	1" 1/4 BSP	MKH G 1 1/4 DN32	
40	1" 1/2 BSP	MKH G 1 1/2 DN40	
50	2" BSP	MKH G 2 DN50	

### Llave 2 vías tubo rígido serie ligera

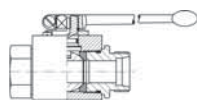

Robinet haute pression 2 voies boisseau sphérique pour tube rigide série légère  
2 Way ball-valves: tube connection serie L DIN 2353  
Rubinetto a sfera maschio DIN 2353 - L -

DN	TUBO PIPE		REFERENCIA PART N°	€
4	6 L	6 L	MKH 6 L	
6	8 L	8 L	MKH 8 L	
8	10 L	10 L	MKH 10 L	
10	12 L	12 L	MKH 12 L	
13	15 L	15 L	MKH 15 L	
16	18 L	18 L	MKH 18 L	
20	22 L	22 L	MKH 22 L	
25	28 L	28 L	MKH 28 L	
25/32	35 L	35 L	MKH 35 L	
25/40	42 L	42 L	MKH 42 L	

### Llave 2 vías tubo rígido L paso total

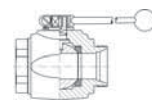

Robinet haute pression 2 voies boisseau sphérique Métrique série légère passage total  
Ball-valves: tube connection serie L DIN 2353 full bore  
Rubinetto a sfera maschio DIN 2353 - L -

DN	TUBO PIPE		REFERENCIA PART N°	€
35	35 L	35 L	MKH 35 L DN35	
42	42 L	42 L	MKH 42 L DN42	

### Llave 2 vías tubo rígido S paso total

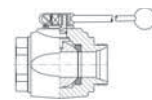

Robinet haute pression 2 voies boisseau sphérique Métrique série légère passage total  
Ball-valves: tube connection serie S DIN 2353 full bore  
Rubinetto a sfera maschio DIN 2353 - S -

DN	TUBO PIPE	REFERENCIA PART N°	€
32	38 S	38 S	MKH 38 S DN32

### Llave 2 vías tubo rígido serie pesada

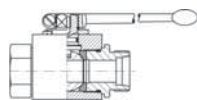

Robinet haute pression 2 voies boisseau sphérique pour tube rigide série lourde  
2 Way ball-valves: tube connection serie S DIN 2353  
Rubinetto a sfera maschio DIN 2353 - S -

DN	TUBO PIPE		REFERENCIA PART N°	€
4	8 S	8 S	MKH 8 S	
6	10 S	10 S	MKH 10 S	
8	12 S	12 S	MKH 12 S	
10	14 S	14 S	MKH 14 S	
13	16 S	16 S	MKH 16 S	
16	20 S	20 S	MKH 20 S	
20	25 S	25 S	MKH 25 S	
13	20 S	20 S	MKH 20 S DN13	
25	30 S	30 S	MKH 30 S	
25/32	38 S	38 S	MKH 38 S	

### Llave 3 vías hembra - hembra - hembra BSP paso en L

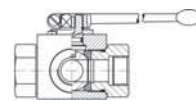

Robinet haute pression 3 voies boisseau sphérique femelle BSP passage en L  
3 Way ball-valve female BSP L flow  
Rubinetto a sfera 3 vie femmina BSP passaggio en L

DN	ROSCA THREAD	REFERENCIA PART N°	€
4	1/8" BSP	MK3A-G 1/8	
6	1/4" BSP	MK3A-G 1/4	
10	3/8" BSP	MK3A-G 3/8	
13	1/2" BSP	MK3A-G 1/2	
20	3/4" BSP	MK3A-G 3/4	
25	1" BSP	MK3A-G 1	
25	1" 1/4 BSP	MK3A-G 1 1/4	
25	1" 1/2 BSP	MK3A-G 1 1/2	

# ▶ Llaves de paso

Robinets | Ball valves | Rubinetti a sfera

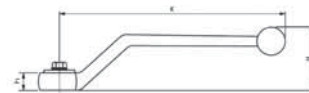

## Manetas | Leviers pour Robinets | Handles for Ball-Valves | Maniglia

Para llaves de paso   Pour robinets For ball-valves   Per rubinetti a sfera	SW	Standard zinc   Standard zinc Standard zinc   Standard zinco		Acero   Acier Steel   Acciaio		INOX/SS316L	
		Referencia   Référence Part no.   Codice	€	Referencia   Référence Part no.   Codice	€	Referencia   Référence Part no.   Codice	€
Serie BSP 1/8 - 1/4 - 3/8 - 1/2 - 5/8	9	A60013155330	*	C600063	*	Z60013155330	*
Serie DIN 6 - 8 - 10 - 12 - 14 - 15 - 16 - 18							
Serie BSP 3/4 - 1 - 1 1/4	14	-	*	C708618	*	Z60013155331	*
Serie DIN 22 - 25 - 28 - 30 - 35 - 38							
Serie BSP 1 1/4 - 1 1/2 - 2	17	-	*	-	*	Z60013155332	*
Serie DIN 35 - 38 - 42							

## Solo se suministra en aluminio | Seulement disponible en aluminium | Only supplied in aluminium | Disponibile solo in alluminio

Para llaves de paso   Pour robinets For ball-valves   Per rubinetti a sfera	SW	Referencia   Référence Part no.   Codice	€
Serie BSP 5/8	12	L501741	*
Serie DIN 15 - 16 - 18			

## Manetas | Leviers pour Robinets | Handles for Ball-Valves | Maniglia



Para llaves de paso   Pour robinets For ball-valves   Per rubinetti a sfera	SW	Zinc   Zinc Zinc   Zinco		Aluminio   Aluminium Aluminum   Alluminio	
		Referencia   Référence Part no.   Codice	€	Referencia   Référence Part no.   Codice	€
Serie BSP 1/8 - 1/4 - 3/8 - 1/2 - 5/8	9	AR603722	*	-	*
Serie DIN 6 - 8 - 10 - 12 - 14 - 15 - 16 - 18					
Serie BSP 3/4 - 1 - 1 1/4	14	A60013155331	*	LR606745	*
Serie DIN 22 - 25 - 28 - 30 - 35 - 38					
Serie BSP 1 1/4 - 1 1/2 - 2	17	-	*	LR801799	*
Serie DIN 35 - 38 - 42					

## Enchufes, Llaves y Racores Giratorios TrAle

Coupleurs rapides, robinets et raccords tournants TrAle

Quick couplings, ball valves and swivel fittings TrAle

Innesti rapidi, rubinetti e giunti girevole TrAle

### Enchufes ISO A TrAle



Coupleurs ISO A TrAle  
Quick couplings ISO A TrAle  
Innesti rapidi ISO A TrAle

DN	ROSCA THREAD	E. C.	REFERENCIA PART N°	€
7	3/8" BSP	M	ZB820106	
10	1/2" BSP	M	ZB820108	
13.2	3/4" BSP	M	ZB820112	
16.9	1" BSP	M	ZB820116	
7	3/8" BSP	H	ZB820206	
10	1/2" BSP	H	ZB820208	
13.2	3/4" BSP	H	ZB820212	
16.9	1" BSP	H	ZB820216	

### Enchufes Paso Total TrAle

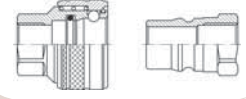

Coupleurs passage total TrAle  
Quick couplings free flow TrAle  
Innesti a passaggio libero TrAle

DN	ROSCA THREAD	E. C.	REFERENCIA PART N°	€
6	1/4" BSP	M	ZB830104	
10	3/8" BSP	M	ZB830106	
13	1/2" BSP	M	ZB830108	
20	3/4" BSP	M	ZB830112	
25	1" BSP	M	ZB830116	
6	1/4" BSP	H	ZB830204	
10	3/8" BSP	H	ZB830206	
13	1/2" BSP	H	ZB830208	
20	3/4" BSP	H	ZB830212	
25	1" BSP	H	ZB830216	

### Enchufes ISO B TrAle



Coupleurs ISO B TrAle  
Quick couplings ISO B TrAle  
Innesti rapidi ISO B TrAle

DN	ROSCA THREAD	E. C.	REFERENCIA PART N°	€
6	1/4" BSP	M	ZB800104	
10	3/8" BSP	M	ZB800106	
13	1/2" BSP	M	ZB800108	
20	3/4" BSP	M	ZB800112	
25	1" BSP	M	ZB800116	
6	1/4" BSP	H	ZB800204	
10	3/8" BSP	H	ZB800206	
13	1/2" BSP	H	ZB800208	
20	3/4" BSP	H	ZB800212	
25	1" BSP	H	ZB800216	

### Llave 2 vías rosca hembra BSP TrAle



Robinet haute pression 2 voies boisseau sphérique femelle BSP TrAle  
2 ways ball valve female BSP TrAle  
Rubinetto a sfera femmina BSP TrAle

DN	ROSCA THREAD	REFERENCIA PART N°	€
4	1/8" BSP	ZGB2V 1/8	
6	1/4" BSP	ZGB2V 1/4	
10	3/8" BSP	ZGB2V 3/8	
13	1/2" BSP	ZGB2V 1/2	
20	3/4" BSP	ZGB2V 3/4	
25	1" BSP	ZGB2V 1	

### Llave 2 vías tubo rígido serie ligera TrAle



Robinet haute pression 2 voies boisseau sphérique sortie pour tube rigide Série légère TrAle  
2 ways ball valve: tube connector light serie TrAle  
Rubinetto a sfera DIN 2353 - L TrAle

DN	TUBO PIPE		REFERENCIA PART N°	€
6	8 L	8 L	ZGB2V 8 L	
8	10 L	10 L	ZGB2V 10 L	
10	12 L	12 L	ZGB2V 12 L	
13	15 L	15 L	ZGB2V 15 L	
16	18 L	18 L	ZGB2V 18 L	
20	22 L	22 L	ZGB2V 22 L	

## Enchufes, Llaves y Racores Giratorios TrAle

Coupleurs rapides, robinets et raccords tournants TrAle

Quick couplings, ball valves and swivel fittings TrAle

Innesti rapidi, rubinetti e giunti girevole TrAle

### Llave 2 vías tubo rígido serie pesada TrAle



Robinet haute pression 2 voies boisseau sphérique sortie pour tube rigide Série lourde TrAle

2 ways ball valve: tube connector heavy serie TrAle

Rubinetto a sfera DIN 2353 - S TrAle

DN	TUBO PIPE		REFERENCIA PART N°	€
4	8 S	8 S	ZGB2V 8 S	
6	10 S	10 S	ZGB2V 10 S	
8	12 S	12 S	ZGB2V 12 S	
10	14 S	14 S	ZGB2V 14 S	
13	16 S	16 S	ZGB2V 16 S	
16	20 S	20 S	ZGB2V 20 S	
20	25 S	25 S	ZGB2V 25 S	

### Racores giratorios rectos



Raccord tournant droit

Straight swivel fittings

Giunti girevoli dritti

ROSCA THREAD	REFERENCIA PART N°	€
1/4" BSP	Z GGL 1/4	
3/8" BSP	Z GGL 3/8	
1/2" BSP	Z GGL 1/2	
3/4" BSP	Z GGL 3/4	
1" BSP	Z GGL 1	
1" 1/4 BSP	Z GGL 1 1/4	
1" 1/2 BSP	Z GGL 1 1/2	
2" BSP	Z GGL 2	

### Racores giratorios 90°



Raccord tournant coude 90°

Elbow 90° swivel female

Giunti girevoli 90°

ROSCA THREAD	REFERENCIA PART N°	€
1/4" BSP	Z GG90 1/4	
3/8" BSP	Z GG90 3/8	
1/2" BSP	Z GG90 1/2	
3/4" BSP	Z GG90 3/4	
1" BSP	Z GG90 1	
1" 1/4 BSP	Z GG90 1 1/4	
1" 1/2 BSP	Z GG90 1 1/2	
2" BSP	Z GG90 2	

## Componentes hidráulicos AISI 316

Composants Hydrauliques AISI 316

Hydraulic Components AISI 316

Componenti Idraulici AISI 316

### Válvulas bidireccionales



Régulateur débit bidirectionnel  
Bidirectional flow control valve  
Valvola di regolazione bidirezionale

ROSCA THREAD		G. F.	REFERENCIA PART N°	€
1/4" BSP	M17x1	25µ	ZFT2251B04	
3/8" BSP	M20x1	25µ	ZFT2251B06	
1/2" BSP	M25x1,5	25µ	ZFT2251B08	
3/4" BSP	M30x1,5	25µ	ZFT2251B12	

### Válvulas unidireccionales



Régulateur débit unidirectionnel  
Unidirectional flow control valve  
Valvola di regolazione unidirezionale

ROSCA THREAD		G. F.	REFERENCIA PART N°	€
1/4" BSP	M17x1	25 µ	ZFT2253U04	
3/8" BSP	M20x1	25µ	ZFT2253U06	
1/2" BSP	M25x1,5	25µ	ZFT2253U08	
3/4" BSP	M30x1,5	25µ	ZFT2253U12	

### Protector manómetro recto



Isolateur de manomètre droit (en ligne)  
Pressure gauge protector (line mounting)  
Esclusore per manometro diritto

ROSCA THREAD		Descripción Description	REFERENCIA PART N°	€
1/4" BSP	1/4" BSPT	RECTO	Z FPE 1G 1/4	

### Protector manómetro 90°



Isolateur de manomètre coudé a 90° (en ligne)  
90° pressure gauge protector (line mounting)  
Esclusore per manometro a 90°

ROSCA THREAD		D. D.	REFERENCIA PART N°	€
1/4" BSP	1/4" BSPT	90°	Z FPEA 1G 1/4	

### Anti-retorno



Anti-retour inox  
Check-valves  
Valvole di ritegno in linea

ROSCA THREAD	TARAJE (bar) SETTING (bar)	REFERENCIA PART N°	€
1/4" BSP	0,5	Z FPR 1/4	
1/4" BSP	2,5	Z FPR 1/4-2.5	
1/4" BSP	5	Z FPR 1/4-5	
1/4" BSP	10	Z FPR 1/4-10	
3/8" BSP	0,5	Z FPR 3/8	
3/8" BSP	2,5	Z FPR 3/8-2.5	
3/8" BSP	5	Z FPR 3/8-5	
3/8" BSP	10	Z FPR 3/8-10	
1/2" BSP	0,5	Z FPR 1/2	
1/2" BSP	2,5	Z FPR 1/2-2.5	
1/2" BSP	5	Z FPR 1/2-5	
1/2" BSP	10	Z FPR 1/2-10	
3/4" BSP	0,5	Z FPR 3/4	
1" BSP	0,5	Z FPR 1	
1" 1/4 BSP	0,5	Z FPR 1 1/4	
1" 1/2 BSP	0,5	Z FPR 1 1/2	

\*Para otras presiones de tarado estandar, consultar/\*\*Pour d'autres pressions ressort standard, consultez-nous/\*\*For other standard spring pressures, consult us//



## Manómetros AISI 316L con glicerina

Manomètre AISI 316L avec glycérine

Manometers AISI 316L with glycerin

Manometri AISI 316 a bagno di glicerina

### Manómetros DN 63 salida vertical



Manomètre DN 63 sortie verticale  
Manometer DN 63 vertical connection  
Manometro DN 63 radiale

ROSCA THREAD	ESCALA (bar) SCALE (bar)	REFERENCIA PART N°	€
1/4" BSP	0-1	ZMFI6304001V	
1/4" BSP	0-2.5	ZMFI63042.5V	
1/4" BSP	0-4	ZMFI6304004V	
1/4" BSP	0-6	ZMFI6304006V	
1/4" BSP	0-10	ZMFI6304010V	
1/4" BSP	0-16	ZMFI6304016V	
1/4" BSP	0-25	ZMFI6304025V	
1/4" BSP	0-40	ZMFI6304040V	
1/4" BSP	0-60	ZMFI6304060V	
1/4" BSP	0-100	ZMFI6304100V	
1/4" BSP	0-160	ZMFI6304160V	
1/4" BSP	0-250	ZMFI6304250V	
1/4" BSP	0-400	ZMFI6304400V	
1/4" BSP	0-600	ZMFI6304600V	

\*Caja AISI 304 (AISI 316L Consultar)/\*\*Boîte AISI 304 (AISI 316L Sur demande)/\*\*Box AISI 304 (AISI 316L On request)/\*\*Cassa AISI 304 (AISI 316L Su richiesta)

### Manómetros DN 63 salida posterior



Manomètre DN 63 sortie arrière  
Manometer DN 63 rear connection  
Manometro DN 63 assiale flangiato

ROSCA THREAD	ESCALA (bar) SCALE (bar)	REFERENCIA PART N°	€
1/4" BSP	0-1	ZMFI6304001DB	
1/4" BSP	0-2.5	ZMFI63042.5DB	
1/4" BSP	0-4	ZMFI6304004DB	
1/4" BSP	0-6	ZMFI6304006DB	
1/4" BSP	0-10	ZMFI6304010DB	
1/4" BSP	0-16	ZMFI6304016DB	
1/4" BSP	0-25	ZMFI6304025DB	
1/4" BSP	0-40	ZMFI6304040DB	
1/4" BSP	0-60	ZMFI6304060DB	
1/4" BSP	0-100	ZMFI6304100DB	
1/4" BSP	0-160	ZMFI6304160DB	
1/4" BSP	0-250	ZMFI6304250DB	
1/4" BSP	0-400	ZMFI6304400DB	
1/4" BSP	0-600	ZMFI6304600DB	

\*Caja AISI 304 (AISI 316L Consultar)/\*\*Boîte AISI 304 (AISI 316L Sur demande)/\*\*Box AISI 304 (AISI 316L On request)/\*\*Cassa AISI 304 (AISI 316L Su richiesta)

### Manómetros DN 100 salida vertical



Manomètre DN 100 sortie verticale  
Manometer DN 100 vertical connection  
Manometro DN 100 radiale

ROSCA THREAD	ESCALA (bar) SCALE (bar)	REFERENCIA PART N°	€
1/2" BSP	0-1	ZMFI10008001V	
1/2" BSP	0-2.5	ZMFI1000802.5V	
1/2" BSP	0-4	ZMFI10008004V	
1/2" BSP	0-6	ZMFI10008006V	
1/2" BSP	0-10	ZMFI10008010V	
1/2" BSP	0-16	ZMFI10008016V	
1/2" BSP	0-25	ZMFI10008025V	
1/2" BSP	0-40	ZMFI10008040V	
1/2" BSP	0-60	ZMFI10008060V	
1/2" BSP	0-100	ZMFI10008100V	
1/2" BSP	0-160	ZMFI10008160V	
1/2" BSP	0-250	ZMFI10008250V	
1/2" BSP	0-400	ZMFI10008400V	
1/2" BSP	0-600	ZMFI10008600V	

\*Caja AISI 304 (AISI 316L Consultar)/\*\*Boîte AISI 304 (AISI 316L Sur demande)/\*\*Box AISI 304 (AISI 316L On request)/\*\*Cassa AISI 304 (AISI 316L Su richiesta)

### Manómetros DN 100 salida posterior



Manomètre DN 100 sortie arrière  
Manometer DN 100 rear connection  
Manometro DN 100 assiale flangiato

ROSCA THREAD	ESCALA (bar) SCALE (bar)	REFERENCIA PART N°	€
1/2" BSP	0-1	ZMFI10008001DB	
1/2" BSP	0-2.5	ZMFI1000802.5DB	
1/2" BSP	0-4	ZMFI10008004DB	
1/2" BSP	0-6	ZMFI10008006DB	
1/2" BSP	0-10	ZMFI10008010DB	
1/2" BSP	0-16	ZMFI10008016DB	
1/2" BSP	0-25	ZMFI10008025DB	
1/2" BSP	0-40	ZMFI10008040DB	
1/2" BSP	0-60	ZMFI10008060DB	
1/2" BSP	0-100	ZMFI10008100DB	
1/2" BSP	0-160	ZMFI10008160DB	
1/2" BSP	0-250	ZMFI10008250DB	
1/2" BSP	0-400	ZMFI10008400DB	
1/2" BSP	0-600	ZMFI10008600DB	
1/2" BSP	0-400	ZMFI10008400DB	

\*Caja AISI 304 (AISI 316L Consultar)/\*\*Boîte AISI 304 (AISI 316L Sur demande)/\*\*Box AISI 304 (AISI 316L On request)/\*\*Cassa AISI 304 (AISI 316L Su richiesta)



## GENERALIDADES

Estas condiciones así como las eventuales condiciones especiales acordadas en el contrato rigen para todas las entregas y todas las prestaciones. Las condiciones de compra del cliente que sean distintas a las aquí establecidas no llegarán a formar parte del contrato al aceptar el pedido. Los contratos se celebran, salvo en el caso de que se haya acordado lo contrario, mediante confirmación escrita del proveedor. En ningún caso, las Condiciones Generales y/o Específicas de Compra del Comprador, anularán o sustituirán estas Condiciones Generales de Venta.

La aceptación de nuestras ofertas implica tácitamente la de todas las condiciones aquí detalladas, salvo las especiales acordadas por escrito, particularmente en la misma Oferta o detalladas en nuestro acuse de recepción de pedido, únicos documentos que nos obligan ante el Cliente.

DICSA se reserva el derecho de propiedad y el derecho de propiedad intelectual de muestras, presupuestos, planos e información en forma material o inmaterial así como en forma electrónica; el acceso de terceros a éstos ha de impedirse.

## OFERTAS Y PEDIDOS

Los precios se entienden, caso de no expresar lo contrario para mercadería situada en nuestro almacén, incluyendo el cargado de ésta, pero sin incluir el embalaje ni el transporte al lugar de recepción, ni impuestos –que serán siempre a cargo del comprador-, así como tampoco la puesta en marcha en el emplazamiento. Todas las operaciones de transporte, seguro, manutención y entrega son a cuenta y riesgo del Comprador.

Las ofertas incluyen solamente los materiales y artículos en ellas especificados disponibles en stock salvo agotamiento y por el plazo de validez determinado en las mismas.

Los estudios u ofertas de material están basados en los precios vigentes en la fecha de su realización, y si, debido a alteraciones en el coste de los materiales, modificación de aranceles o a cualquier otra causa, el nivel de precios fuese revisado, los precios que se aplicarían serían aquellos que rijan en la fecha del suministro, a menos que la oferta sea aceptada dentro del plazo de validez que en la misma se fije.

Los precios no incluyen, excepto notificación expresa, el montaje y la puesta en marcha de los materiales suministrados, los fluidos recomendados por los servicios técnicos de los fabricantes, los contenedores tanto rígidos como elásticos de los materiales, así como el estudio de implantación de los distintos materiales.

DICSA podrá variar el precio, como consecuencia de cualquier ley que afecte a materiales, salarios o a las horas de trabajo y también a posible cambios en la paridad de la moneda, en elementos de importación.

Los pedidos no serán tomados en consideración a menos que vengan acompañados de la cantidad a cuenta prevista en nuestra Oferta, si así se ha establecido.

La aceptación de la Oferta supondrá igualmente la aceptación sin reservas de estas Condiciones Generales de Venta.

## ESTUDIOS, PLANOS Y DISEÑOS

La información relacionada con la oferta, tal como planos, diseños, dibujos catálogos y/u otra documentación técnica, es solamente informativa y tienen como objeto dar una imagen general de los materiales en ellos descritos, no formando parte del contrato a menos que haya habido algún acuerdo por escrito. DICSA no aceptará ningún tipo de responsabilidad por la inexactitud u omisión de dicha documentación.

El Cliente deberá hacer siempre un estudio previo de compatibilidad y de montaje de los elementos en su instalación y será el único responsable de la puesta en conformidad de dicha instalación con las distintas reglamentaciones vigentes.

En presupuestos, planos, esquemas y otras informaciones técnicas, mantendremos reservado el derecho de propiedad y de realización, no permitiendo que estos sean facilitados a terceros sin nuestro consentimiento escrito.

DICSA se reserva el derecho de propiedad de la mercancía suministrada hasta el pago completo del precio establecido. DICSA se reserva el derecho de propiedad de los planos de la mercancía, que no serán facilitados ni vendidos a terceros en ningún caso.

## TRABAJOS IN SITU

Los presupuestos de los trabajos realizados en el lugar de la obra del cliente son considerados orientativos, debido a las características particulares y especiales que pueden representar, no pudiendo dar lugar, excepto acuerdo definitivo entre las partes, en precios definitivos.

## REPARACIÓN

Los trabajos de reparación no se empezarán hasta la aceptación escrita, por parte del Cliente, del presupuesto y de las condiciones que se establezcan.

En el supuesto de que el presupuesto no sea aceptado por el Cliente en el plazo de un mes, los gastos derivados del desmontaje, almacenaje, peritaje y portes correrán a cargo del Cliente. Si el Cliente solicita la reparación antes de aceptar el presupuesto, los trabajos se llevarán a cabo lo antes posible y, por su parte, el Cliente deberá aceptar el coste final de la reparación.

## GENERAL TERMS

These conditions, together with the eventual specific conditions accorded in the contract, apply to all deliveries and all services. The purchase conditions of the customer, if different from those herein established, will not be part of the contract on having accepted the order.

The contracts are concluded, unless otherwise agreed upon by the Parties in writing, by means of written confirmation of the supplier. The General Conditions and / or Specific Conditions of Purchase of the Buyer, cannot, in no case, cancel or replace these General Conditions of Sale.

The acceptance of our offers implies tacitly the acceptance of all the conditions detailed herein, except the special ones that have the agreement in writing, particularly in the same offer or detailed in our accuse of receipt of order, the only documents that oblige us before the Customer. DICSA has the right of property and the right of intellectual property of samples, budgets, technical documentation and information in material or immaterial form as well as in electronic form; the access of third parties to these documents must be forbidden.

## OFFERS AND ORDERS

Except in case of having expressed the opposite, the prices include the merchandise placed in our store, including its loading, but without including the packing nor the transport to the place of receipt, nor taxes, nor the getting started - these will always be at the expense of the customer. All the operations of transport, insurance, handling and delivery are on the account and risk of the Customer.

The offers include only the materials and products expressed in them, available in stock until end of stock, with the term of validity expressed in the same offers.

The studies or offers of material are based on the prices on the date the offer was made, and if, due to changes in the cost of the materials, modification of duties or to any other reason, the level of prices was checked, the prices that would be applied would be those that apply in the date of the delivery, unless the offer is accepted in the term of validity expressed in it.

The prices do not include, unless specific notification, the assembly and the getting started of the supplied materials, the fluids recommended by the technical services of the suppliers, the containers of the materials, as well as the study of the setting up of the different materials. DICSA may change the price, as a consequence of any law that concerns materials, wages, or the working hours, but also as a consequence of probable changes in the parity of the currency since it concerns the elements of import.

The orders will not be taken in consideration unless they are provided with the specific amount in our account, foreseen in our Offer, if this condition has been pre-established. The acceptance of the Offer will suppose equally the acceptance without reserve of these General Conditions of Sale.

## STUDIES, TECHNICAL DOCUMENTATION

The information related to the offer, as technical documentation, designs, drawings, catalogues and / or any other technical documentation, is only informative and they have as object to give a general image of the materials described in them, they do not form a part of the contract unless written agreement. DICSA will not accept any type of responsibility for inaccuracy or omission of the above mentioned documentation.

The Customer will always have to do a previous study of compatibility and of assembly of the elements in his installation and will be the only responsible for the putting in conformity of the above mentioned installation with the current regulations. In offers, drawings, schemes and other technical information, we reserve ourselves the right of property and of design, not allowing that these should be facilitated to third parties without our previous written assent.

DICSA retains the property of the supplied merchandise until full payment of the agreed price. DICSA also retains the property of the Product's project, which in no circumstances shall be disclosed or sold to third parties.

## THE ASSEMBLIES AT THE LOCATION (PLANT) OF THE CUSTOMER

The offers of the assemblies done for the customer, in his elected location of work, are considered as an estimate (approximate calculation), due to the particular and special characteristics that they can represent, not being able to give place, except final agreement between the parts, to final prices.

## REPAIRMENT

The works of repair will not begin until written acceptance, on the part of the Customer, of the offer and of the conditions established in it. Supposing that the offer is not accepted by the Customer within one month, the expenses derived from the disassembly, storage, survey and freightage will be chargeable to the Customer. If the Customer requests the repair before accepting the offer, the assemblies will be carried out as soon as possible and, for his part, the Customer will have to accept the final cost of the repair.

In case of delivery of new products in exchange for the repair, if this one was out of guarantee, the Customer will have to accept the payment corresponding to it. The budgets of repair are always as estimation and should not be considered as final prices.

En caso de entregarse productos nuevos a cambio de la reparación, si esta estuviera fuera de garantía el Cliente deberá aceptar el cargo correspondiente a la misma.

Los presupuestos de reparación siempre son orientativos y en ningún caso deben tomarse como precios finales.

### PLAZOS DE ENTREGA

DICSA se reserva la facultad de rechazar un pedido en función de la disponibilidad de los productos. En este supuesto, lo comunicará al comprador con la mayor brevedad posible.

El plazo de entrega será acordado por las partes contractuales. Los plazos de entrega se calcularán desde la fecha de recepción de la confirmación del pedido, pudiendo DICSA proceder sin interrupción alguna. DICSA no será responsable de las demoras en el suministro de toda o parte de la mercancía en el caso de fuerza mayor, tal como catástrofes naturales, limitaciones legales, huelgas, etc., o cualquier otra causa fuera de nuestro control. En el caso de darse alguna de las razones anteriormente citadas, el periodo de entrega se hará extensible al mismo periodo de tiempo que dure la causa que haya motivado el retraso. Sin embargo, si el periodo excediera de seis meses, DICSA podrá cancelar la parte no enviada notificando previamente por escrito al comprador.

Procuramos con el mayor interés, cumplir los plazos de entrega que se indican en nuestras ofertas o en nuestras confirmaciones de pedido, si bien es materialmente imposible responder plenamente de dicho cumplimiento, por depender de otros proveedores y de inesperadas circunstancias totalmente ajenas a nuestro posible control.

De ahí que no se aceptarán sanciones por demora en la entrega prevista.

### DERECHO DE PROPIEDAD

DICSA mantiene la propiedad de la mercancía hasta que el comprador realice el pago por completo de la misma.

Será responsabilidad del comprador tomar las medidas necesarias para conservar en buen estado la mercancía hasta que haya sido pagada, debiendo asegurarse a DICSA el cobro de la misma en caso de haber sido vendida a terceras personas por el comprador.

### GARANTÍA

No se responderá de ninguna reclamación que no sea efectuada dentro de los 12 meses siguientes a la entrega de la mercancía, ni se aceptarán devoluciones sin autorización previa o pasados 15 días desde la entrega de la mercancía. En cualquier caso, toda devolución deberá ir acompañada de copia de nuestra autorización y, siempre que no sea por causas imputables a DICSA, conllevará un recargo mínimo del 20% sobre el coste del material devuelto, corriendo todos los gastos a cargo del cliente.

En relación con los defectos que aparezcan en los productos suministrados, DICSA aceptará como única responsabilidad u obligación, abonar la pieza o piezas defectuosas siempre que la mercancía haya sido tratada adecuadamente y que los defectos surgidos sean debidos a defectos de material o fabricación.

La garantía comprende la reposición o reparación de los elementos defectuosos a realizar en nuestros talleres.

La garantía se entiende siempre con el material presumiblemente defectuoso depositado en nuestras instalaciones, con los gastos de transporte y riesgo a cargo del comprador.

Los consejos y asesoramiento dados antes y post cierre del contrato, se realizan con la mejor intención y según nuestros máximos conocimientos, no obstante DICSA no asume ninguna clase de responsabilidades a este respecto, ni responderá de los eventuales daños directos o indirectos que indistintamente, por quién, dónde y por qué puedan producirse.

DICSA no será responsable de ninguna consecuencia o ningún daño indirecto producido al Comprador o a terceros, incluyendo los daños de pérdida de oportunidades, negocio o ingresos.

DICSA garantiza exclusivamente sus materiales excluyendo cualquier responsabilidad por los efectos o perjuicios que estos puedan provocar en instalaciones, maquinarias o circuitos. En ningún caso se responsabilizará de los accidentes personales o materiales y pérdidas de producción.

Se excluye de la garantía las averías producidas por mal uso o deficiente instalación, averías provocadas por sometimiento de los equipos a esfuerzos anormales con fines experimentales, de ajuste o prueba. La total responsabilidad de DICSA por los daños causados, independientemente del tipo de acción o teoría de la responsabilidad, no excederá del importe de la obra, instalación o materiales que haya sido objeto de pedido a DICSA. Cualquier importe que supere dicha cantidad y que DICSA se vea obligada a soportar ya sea por decisión judicial, arbitral o similar, será repetida a la compradora hasta lograr indemnidad.

Se encuentran excluidos de esta garantía:

- El uso de instalaciones o servicios, que se aparten de los manuales de instrucción o especificaciones de DICSA.
- El uso inadecuado de instalaciones o negligencia del Comprador, sus Ayudantes o Agentes.
- Las partes suministradas por el Comprador.

### DELIVERY TERMS

DICSA saves itself the right to reject an order depending on the availability of the products. In this supposition, DICSA will communicate it to the Customer as promptly as possible.

The delivery time has to be approved by the contractual parts. The delivery time will be calculated from the date of receipt of the confirmation of the order, when DICSA will be able to proceed without any interruption. DICSA will not be responsible for the delays in the supply of all or in part of the goods in case of major force, such as natural catastrophes, legal limitations, strikes, etc., or any other reason beyond our control. In case of any of the reasons previously mentioned, the period of delivery will be extensible to the same period of time that lasts the reason that has motivated the delay. Nevertheless, if the period exceeds six months, DICSA may cancel the part that couldn't be sent, by previously notifying the Customer in writing.

We do our best to respect the delivery times that are indicated in our offers or in our order confirmations, though it is materially impossible to answer completely for the above mentioned fulfillment, since we depend on other suppliers and on unexpected circumstances totally foreign to our possible control. Won't be accepted any sanctions for the delay in the foreseen delivery.

### RIGHT OF PROPERTY

DICSA maintains the property of the materials (products) until the Customer makes the payment in full of the merchandise.

The Customer is responsible for taking the necessary actions to preserve in good condition the merchandise until it has been paid, must insure DICSA of the payment of the same one in case of having being sold to third persons by the Customer.

### WARRANTY

We won't attend any claim done after the 12 months following the delivery of the merchandise. Returned material will not be allowed without previous authorization or when the time between the purchase and the request for return exceeds 15 days.

In any case, all returned merchandise will have to be accompanied by a copy of our authorization and, providing that it is not for reasons attributable to DICSA, will carry a minimal surcharge of 20 % on the cost of the returned material, all the expenses will be charged to the customer. Concerning the faults that appear in the supplied products, DICSA will only accept as unique responsibility or obligation, the paying of the product or defective products providing that the products (merchandise) have been treated adequately and that the arisen faults are due to faults of material or manufacture.

The warranty includes the replacement or repair of the defective elements in our workshops. The warranty is understood always in relation with the presumably defective material deposited in our warehouse, but the costs of transport and the risk being at the expense of the Customer. The advices given before and post closing of the contract, are made with the best intention and according to our know-how, nevertheless DICSA does not assume any category of responsibilities in this regard, nor will answer of the eventual direct or indirect damages that could take place indistinctly, no matter who, where and why they may take place.

DICSA will not be responsible for any consequence or indirect damages occurred to the Customer, and / or third Parties including but not limited to loss of opportunities, business and incomes.

DICSA guarantees exclusively its own materials, excluding any responsibility for the effects or damages that these could provoke in facilities, equipments or conductions. In no case will take responsibility for accidents related to individuals or materials or for losses in fabrication.

The warranty excludes the breakdowns produced by badly use or deficient installation, breakdowns provoked by overloading of the equipments for experimental purposes, either for adjustment or testing. DICSA's total responsibility for the caused damages, independently of the type of action or theory of the responsibility, will not exceed the amount of the work done, installation or materials that have been object of the order to DICSA.

Any amount that exceeds the above mentioned quantity, and any amount that DICSA will have to support either for judicial, arbitral or similar decision, will be transmitted to the Customer until obtaining indemnity.

Will be excluded from this warranty:

- The use of facilities or services, which are different of those included in the manuals of instruction or in DICSA's specifications.
- The inadequate use of facilities or negligence of the Customer, his Assistants or Agents.
- The parts supplied by the Customer.

### FREIGHTAGES

By merchandise we always mean the one deposited in DICSA's warehouse, even in operations conditioned by the delivery at destination and the merchandise will always travel at the account and risk of the Customer, being at his charge, including the additional insurances that could be established and the special permissions it may need. According to what it is established in the article 18 of the Royal decree 782/1998 concerning wrapping and packaging mentioned in the

**PORTES**

La mercancía se entiende siempre depositada en el domicilio de DICSA, incluso en operaciones condicionadas a la entrega en destino y la mercancía siempre viajará por cuenta y riesgo del comprador, siendo a su cargo inclusive los seguros adicionales que pudieran establecerse y los permisos especiales a que hubiera lugar.

Según se establece en el artículo 18 del Real Decreto 782/1998 para los envases y embalajes acogidos a la Disposición adicional 1.ª de la Ley 11/1997, el responsable de la entrega de los residuos de los embalajes y envases usados, para su correcta gestión ambiental, será el usuario final.

**ENVÍOS DE EMERGENCIA**

Sea cual fuere el medio de transporte utilizado, avión, courier, régimen de equipajes, agencias especiales, mensajeros etc. Independientemente del importe de dicho servicio, el comprador correrá con todos los gastos extra, los de acarreos, de desplazamientos, y de comunicaciones que el servicio haya ocasionado, sin que en ningún caso este valor pueda ser inferior a 60 euros.

**PEDIDOS ESPECIALES**

Todo pedido de material especial, conllevará el pago anticipado del 50% del importe del pedido, como condición indispensable para su aceptación. Dicho importe quedará siempre a favor de DICSA como indemnización en cualquier caso de anulación por parte del comprador, sin perjuicio de las reclamaciones que por Ley se puedan tener derecho.

**VENTA MÍNIMA**

La facturación mínima será de 50 € sea cual sea el importe del pedido.

**PAGOS**

Los pagos se realizarán como máximo y salvo acuerdo expreso entre las partes, a 60 días desde la fecha de la factura y previa recepción de los informes positivos de crédito. Si el comprador no efectuare el pago de cualquiera de los suministros a su vencimiento, DICSA está autorizado a suspender los envíos posteriores hasta que se realice dicho pago. Cualquier cargo bancario asociado con el pago de la mercancía, así como los gastos de devolución de efectos en caso de impago, serán por cuenta del comprador.

En caso de demora en el pago y sin perjuicio de otros derechos atribuidos al comprador por la legislación en vigor, el comprador abonará a DICSA un interés de demora del 2% mensual desde la fecha de vencimiento de la factura.

**COBRO DE LETRAS O RECIBOS DEVUELTOS O APLAZADOS**

Serán a cargo del librado:

- Gastos de devolución.
- Intereses del 1% mensual desde el día del vencimiento fallido hasta la fecha de cobro definitivo.
- Posible valor del timbre de nuevos documentos.
- Prima de seguro de crédito.

**PAGOS COINCIDENTES EN VACACIONES**

Si el cliente no pudiese atender los pagos que coincidiesen con periodos vacacionales, éstos se trasladarán al mismo día del mes anterior. En caso de existir días fijos de pago, el vencimiento se trasladará al día hábil de pago inmediatamente anterior.

**USO DE SOFTWARE**

En la medida en que el volumen de entrega incluye la puesta a disposición de software, el cliente tiene el derecho no exclusivo a usarla incluyendo la documentación adjunta. Se le cede el software para el uso en el objeto de entrega al cual va destinado. No se admite el uso de este software en otro sistema. La modificación, traducción o adaptación de código de objeto a código de origen así como la reproducción de software solamente se admite en la medida legalmente establecida. El cliente se compromete a no retirar las indicaciones del fabricante, especialmente indicaciones del Copyright sin el consentimiento previo de DICSA. Todos los demás derechos sobre el software y la documentación incluyendo las copias, corresponden a DICSA o al proveedor del software. No se admite la concesión de sublicencias.

**DERECHO APLICABLE Y JURISDICCIÓN**

Las relaciones jurídicas entre DICSA y el comprador están sujetas al derecho Español. El tribunal competente será el del domicilio de DICSA. Sin embargo, DICSA podrá optar por interponer las acciones legales correspondientes en el domicilio del comprador.

1ª additional Disposition (Regulation) of the Law 11/1997, the person responsible for the delivery of the residues of the packaging and worn packages, for the correct environmental management, will be the final user.

**EMERGENCY DELIVERIES**

No matter the type of the transportation used: by plane, courier, as baggage (luggage), special agencies, messengers etc; independently of the amount of the above mentioned service, the Customer will pay all the extra expenses, those of transportations, of shipping, and of communications that the service has caused; this value may not, under no circumstance, be lower than 60 euros.

**SPECIAL ORDERS**

Any order (request) of special material, will carry the anticipated payment of 50 % of the amount of the order (request), as an indispensable condition for its acceptance. The above mentioned amount will always be in favor of DICSA as compensation in case of cancellation on the part of the Customer, without prejudice of the claims at which they may have right by Law.

**MINIMAL SALE**

The minimal invoice will be of 50 €, no matter the amount of the order.

**PAYMENTS**

The payments have to be done, except express written agreement between the parts, in maximum 60 days from the date of the invoice and previous receipt of the positive reports of credit. If the Customer doesn't make the payment in time, for a part of the merchandise supplied, DICSA is authorized to suspend the posterior deliveries until the Customer executes the due payments. Any bank charges associated with the payment of the merchandise, as well as the expenses of return of it in case of non-payment, will be at the expense of the Customer. In case of delay in the payment and without prejudice of other rights attributed to the buyer for the legislation in effect, the Customer will pay to DICSA an interest of monthly delay of 2 % starting from the date when the invoice comes to its term.

**UNPAID OR POST-PONED INVOICES**

Will be at the expense of the Customer:

- The return expenses.
- Monthly interests of 1%, from the day when the payment has come to its term and wasn't made, until the date of full payment.
- Possible amount (value) of the stamp of the new documents.
- The credit insurance.

**COINCIDENTAL PAYMENTS IN VACATIONS**

If the client could not attend to the payments that were coinciding with vacation periods, these will move to the same day of the previous month. In case there are fixed days of payment, the term of the invoice will move to the immediately previous working day of payment.

**THE SOFTWARE USE**

If the delivery includes the putting at the disposal of the Customer software, the Customer has the exclusive right to use it, including the attached documentation. The software is sent for the use in the object of delivery to which it is destined. It is forbidden the use of this software into any other system. The modification, translation or adjustment of the code of object to code of origin as well as the reproduction of software is only admitted into the legally established limits. The Customer promises not to withdraw the indications of the manufacturer, especially the indications of the Copyright, without DICSA's previous assent. All the other rights on the software and the documentation including the copies, they belong to DICSA or to the supplier of the software. The concession of sublicenses is not admitted.

**GOVERNING LAW AND JURISDICTION**

These General Conditions and any agreement between DICSA and the Customer shall be exclusively governed by Spanish laws. The exclusive jurisdiction on any dispute between the DICSA and the Customer shall be the courts of DICSA's domicile. Nevertheless, DICSA has also the right to bring legal action against the Customer before the courts of the place of business and/or residence of the Customer.







ISO 9001

BUREAU VERITAS  
Certification

